

## Raptor<sup>®</sup> Cone Crusher

Smart cone crushers with advanced control systems for material and rock processing applications

- Raptor® Cone Crusher

# Complete connectivity and optimised control system for high throughput and reduced maintenance

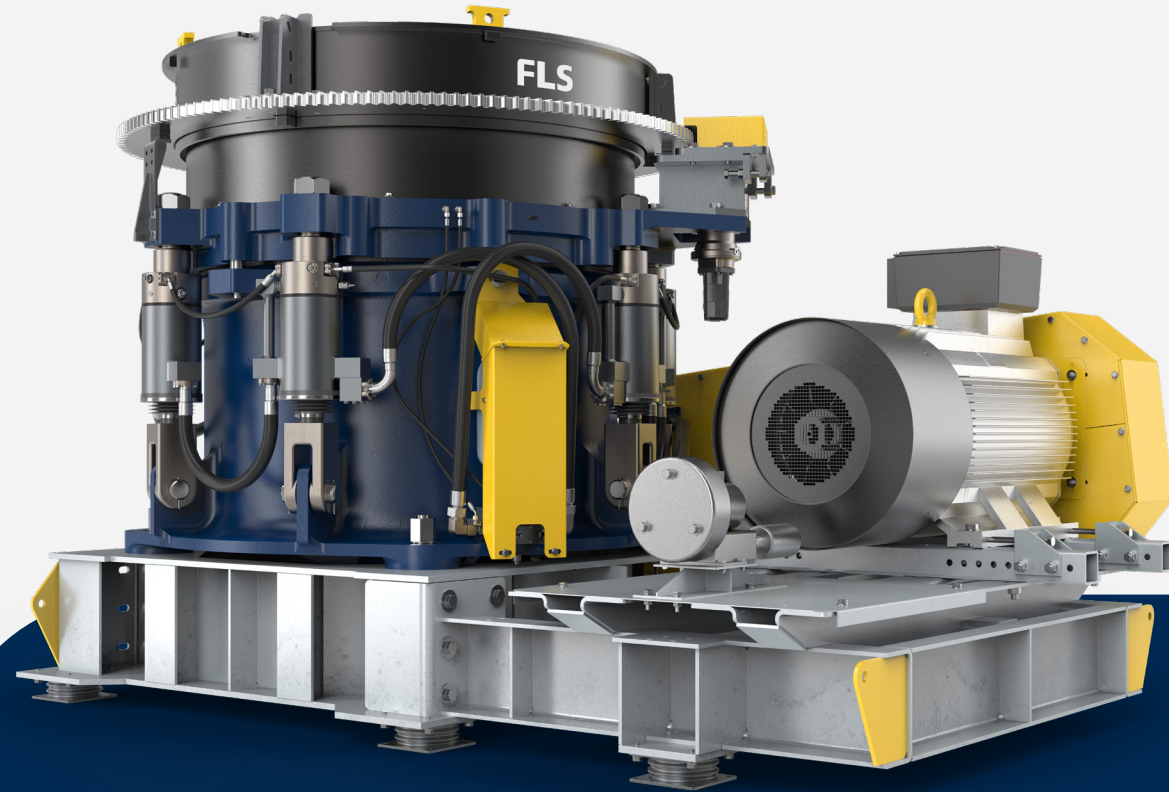

## Key benefits



**Reduce unplanned  
downtime**



**Optimise asset and  
plant performance**



**Remote data  
visibility**



**Increase  
consistency of  
particle size**

## Achieve maximum throughput with the new range of Raptor cone crushers available in R250, R350 and R450 models

specifically designed for the aggregates industry. With an integrated user-friendly control system, these configurable, safe crushers are suitable for even your toughest applications.



### Remote monitoring - all day, every day

Representing the latest in smart technology and connectivity for your operation, our cone crushers are connected to the cloud, providing operational and asset health monitoring metrics 24/7.

### Advanced automation and control system

Advanced overload sensing technology detects crushing force overload, and if desired, the advanced automation system can take necessary corrective action. The same system can be used to optimise your crusher performance with feed control, setting adjustment and monitoring of critical lubrication and hydraulic parameters. This means improved efficiency and lower cost for your business.

### Machine optimisation software

Original Equipment Manufacturer (OEM) is designed to safely operate the machine at its peak performance. It has self-diagnostic capabilities, incorporating state-of-the-art operator logs. The crusher is ready for integration with most protocols and central/plant control systems. Your crusher is protected so it maintains high reliability. Liner life is increased and the crusher provides a consistent product capacity and gradation.

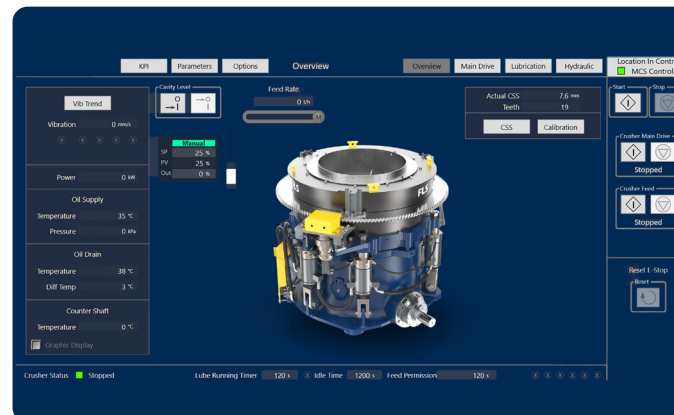

### Ask yourself if your crusher is reliable, operating at full capacity, or needs an upgrade to meet production goals?

Do you need a reliable crusher with a low operating cost?

Is your plant falling short on capacity?

Do you have the opportunity to produce a new product size?

Do you need to upgrade an old crusher?

Do you want a partner with expert knowledge in process, maintenance and liner optimisation?

# A smarter solution with complete digitalisation

Raptor cone crushers are designed for high productivity and efficiency, and low operational and wear costs. With input from plant operations and maintenance personnel around the globe, we've made sure that the designs incorporate features which reduce your maintenance time while increasing production.

## Improved consistency of particle size

The innovative software helps maintain desired output through power-based control or particle size analysis, which automatically adjusts the close-side settings. The benefit is increased consistency of particle size.

## Remote data visibility

You can remotely monitor operational and health metrics of the crusher, and set alarm limits with push notifications available on your mobile phone, thanks to the remote data visibility. You have visibility to key metrics such as tonnage, PSD, liner life, and other key health and operational metrics. This allows better decision-making for the operation. No more being kept in the dark.

## Maximum reduction ratios

With a combination of variable speed and large throw, Raptor cone crushers provide high reduction ratios. Because of their efficient crushing action, the crushers have a large power utilisation per cone diameter. The high cavity density improves inter-particle crushing action for end products, with a more consistent gradation and superior product shape (cubicity).

## Accessible

Best-practice design gives you better access to the inside of the crusher through features such as main frame inspection ports, cartridge countershaft boxes and specially-designed tools.

## Structural integrity

The critical load bearing components of the Raptor cone crushers meet specifications that typically exceed what is commonly offered in a conventional cone crusher. The major components are cast of high grade steel and the eccentric material selection provides greater certainty of a reliable surface finish over a long period of service.

## Less downtime, high protection

Our advanced fastening system for mantle and bowl liners requires no backing material allowing for quicker liner change-out times, at a reduced cost. For liner changing, the same hydraulic motor which rotates the bowl for setting the crushing gap will rotate the bowl completely out. With this system, it is easy to change to different crushing chambers and to react to different applications. The dual-action tramp release design protects the crusher from uncrushable material by allowing the bowl to raise up. This increases the crusher gap so the tramp material will safely exit. The tramp release returns the bowl back to its original position after passing the tramp iron, so no downtime occurs.

Should your crusher shut down with material in the crushing chamber these same dual-acting hydraulic cylinders will raise the bowl. This evacuates the chamber of uncrushed material allowing the crusher to easily restart. That means no more manual digging out the crusher.

## Security

Raptor cone crushers employ "fail safe" hydraulics to ensure protection from mechanical overload should an accumulator bladder fail. If the accumulator does fail, internal relief valves within the dual-acting tramp release cylinders provide immediate, alternate protection from severe and costly structural damage to the crusher. Another standard safety feature is the counter-clockwise rotating crushing action. This prevents the machine from self-tightening when adjustment ring movement is excessive (ring bounce), or if the ring gear brake or thread clamping fails.

## Superior bronze bearing technology

Bronze sleeve bearings are used for all internal moving components that are load bearing or involved in load transmission. Our bronze technology is custom engineered to meet specific application demands.

# Purpose-built crushers for the aggregates industry

## You can rely on our expertise

FLS offers a superior range of smaller cone crushers with the Raptor R250, R350 and R450 models (upgrades of the 200, 300 and 400 models). They are indispensable in the production of construction aggregates and help you maintain better control of the size and shape of your product.

## Your needs guided the design

Safety, ease of maintenance and the highest possible throughput – this is what you want in a crusher. It is also the motivation driving the design of the Raptor cone crushers. We have listened to you, and your needs have guided the design.

## Integrated advanced control system

Our integrated advanced machine control system is ready for you with multiple optimisation options as well as data visibility and remote asset monitoring. This means you stay on top of the operational health of your investment.

## Unequaled versatility and productivity

The most reliable and maintenance-friendly option on the market, Raptor cone crushers have flexibility of speed, giving them unequalled versatility and productivity.

Every crushing project is different and requires a unique solution. That's why the range of Raptor cone crushers is configurable to meet your unique needs. You can operate them, secure in the knowledge that your most common challenges are being addressed. You'll also get better results at decreased costs.

## Excellent product gradation

The aggregates and sand and gravel industries are ever-changing, with increasing demand for a narrow range of single-size aggregates, and we stay on top of the latest requirements and technologies.

The new R250, R350 and R450 models, with a higher stroke, will produce a better particle shape and reduce the circulation load in a closed circuit. Because of the lower circulation load, they also produce less sand. This means less waste - a vital factor in a business when sustainability is a high priority.

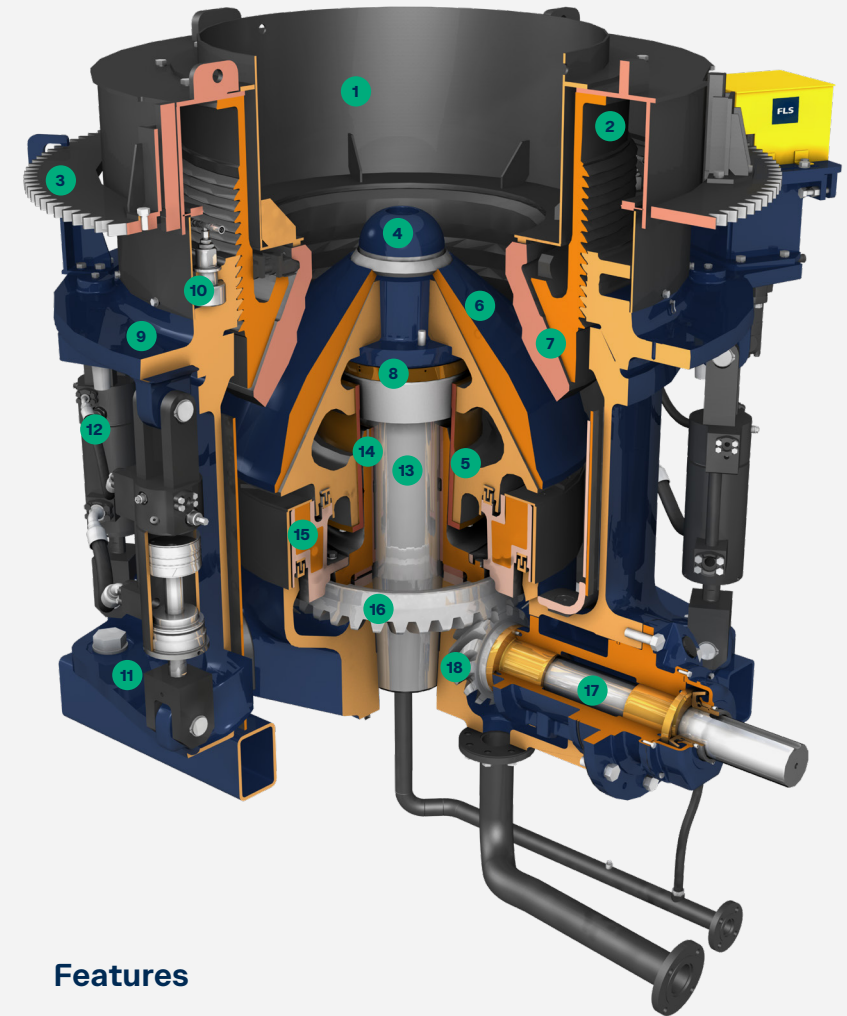

## Features

- |                    |                            |
|--------------------|----------------------------|
| 1. Hopper          | 10. Clamping cylinder      |
| 2. Bowl            | 11. Main frame             |
| 3. Drive ring      | 12. Tramp release cylinder |
| 4. Feed plate      | 13. Main shaft             |
| 5. Head            | 14. Eccentric              |
| 6. Mantle          | 15. Counterweight          |
| 7. Bowl liner      | 16. Gear                   |
| 8. Socket liner    | 17. Countershaft           |
| 9. Adjustment ring | 18. Pinion                 |

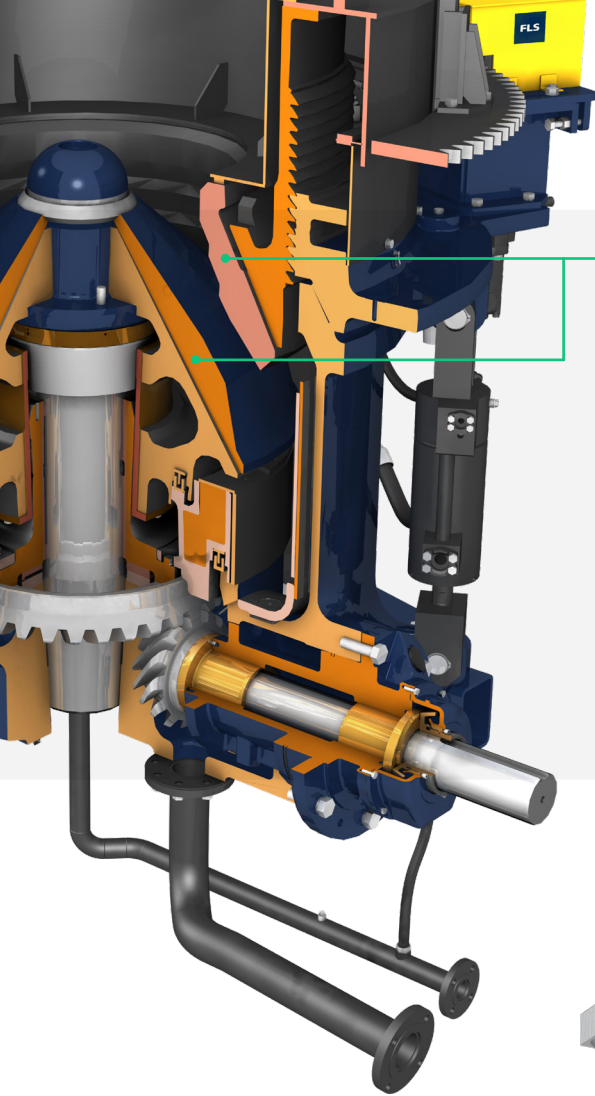

**No liner backing material**

The Raptor cone crusher requires no backing material behind the mantle or bowl liner. This simplifies and speeds-up the complete change-out process.

The crusher no longer needs to be down waiting for the backing material to dry. This reduces the amount of time for your maintenance personnel to change out liners.

No epoxy backing material means no need to maintain MSDS data sheets or store and handle hazardous substances. Giving you one less thing to worry about.



**Inverted tramp release cylinders**

The entire range of Raptor cone crushers incorporates inverted tramp release cylinders. The cylinder rod faces downwards and is covered with a protective boot to shield from debris. Since the rod is beneath the cylinder any fines are unable to accumulate on the rod.

This simple and effective innovation decreases surface wear and improves seal life. That results in less inspection, cleaning and maintenance.

In addition, each tramp cylinder is mounted with a bypass relief valve. This provides added security should a tramp event occur.



**Three arm mainframe design**

This simple design feature increases the discharge open area allowing for improved capacity. The third arm encloses the countershaft box providing a more robust mainframe design. The three arm mainframe also reduces the time and money spent on replacing and stocking arm guard liners.

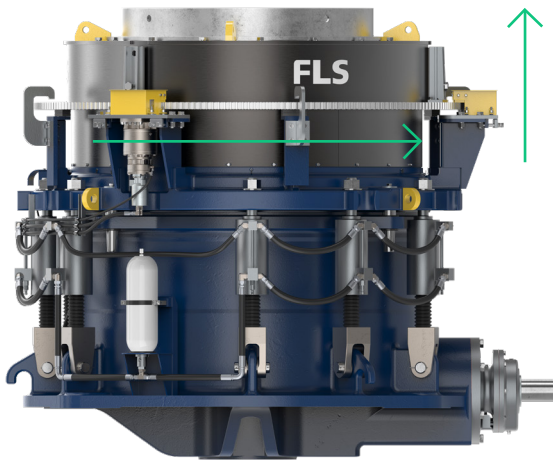

### Eliminating ring bounce

Quarries are often over-working their crushers as they push to obtain larger reduction ratios while processing harder materials. This can lead to “ring bounce”, a detrimental event that causes the bowl assembly to repeatedly raise up and slam back down.

This takes its toll on the crusher - increased wear and tear, more frequent maintenance and a greater chance of catastrophic failure.

We have prevented ring bounce by designing the threads on the crusher to allow the bowl opening the CSS gap.

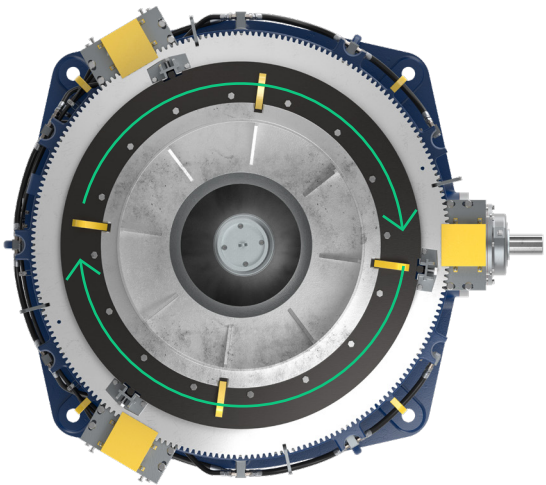

### Single, independently-mounted accumulator

A single accumulator is mounted independently from the cylinders. This allows for just the use of one accumulator, fewer than conventional designs. That means less potential failure points, quicker and easier maintenance, and fewer spare parts.

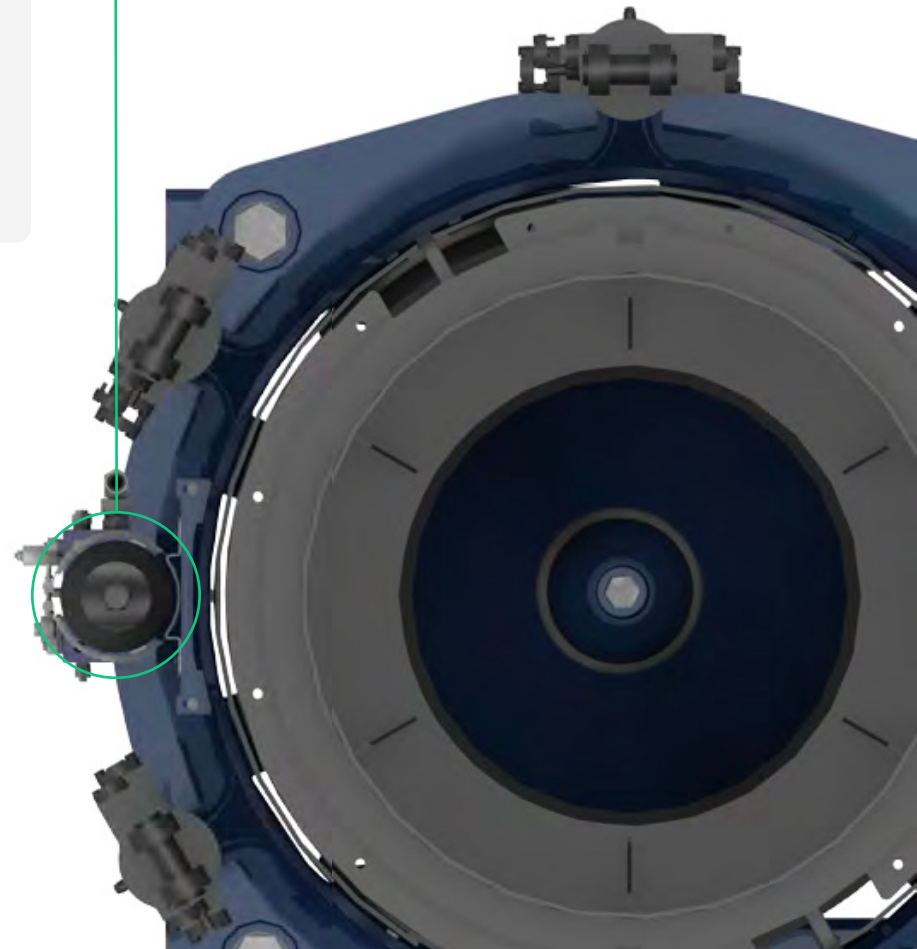

# Premium cone crushers for all your crushed stone quarrying applications

## Ease of installation

The Raptor cone crushers R250, R350 and R450 are easy to install. The unit (crusher, lubricant and hydraulic skids) arrives onsite at your site location on a structural frame that can be mounted to a concrete foundation or mobile unit. With the FLS machine control system it is ready to go or it can easily be connected to the plant's central control system.

## After-sales service

You receive the benefits of FLS supply chain and 100 percent integrated unit of supplied components.

You know that we will be on board with you all the way with options including:

- Technical advice and audits
- Complementary products such as crusher liners and supply of spares
- On-site and workshop service (rebuilt, retrofits and modernisations)
- Optimisation software to integrate your entire operation.

We optimise complete crushing circuits and utilise a crushing plant simulation to ensure you find the best crusher for your application.

Additionally, we offer service agreements and training so that your operators will know how best to operate your Raptor cone crushers safely and efficiently.

## Raptor R250

Like its predecessor (Raptor 200), the R250 has a wide speed range, which gives you greater flexibility in production, along with a durable, low-profile design and the ability to be fitted onto a portable chassis. The inverted tramp release cylinders keep hydraulics cleaner than conventional designs. Unique to the R250 is the integrated countershaft box as well as a single head bushing combined for easier maintenance and lower cost for your business.



## Raptor R350

The Raptor 350 also offers the versatility of a wide speed range to give you more flexibility in production. This machine is ideal for generating high quality product at a constant setting under consistently high loads. This model features advanced hydraulics which ensure protection from mechanical overload through bypass release. This also protects the hydraulic cylinders should the accumulator fail. Productive and versatile, the R350 can be quickly mounted and is ideal for wheeled and skid type chassis.



## Raptor R450

The Raptor R450 is ideal as a secondary crusher following a jaw crusher. This machine gives you more usable and saleable aggregate per tonne processed than competitive models in its class. Versatile and highly portable, the Raptor R450 can accept primary-crushed ore from a jaw crusher with greater flexibility (up to 25% larger material) because of its 1.3m (52-inch head) diameter, large feed opening, high-pivot-point crushing action, and wide crushing stroke. Outstanding gradation control and cubical product also make the R450 an excellent tertiary crusher for aggregate, asphalt or concrete products.



**Raptor R250 capacity chart**

	Setting (mm)	mt/hr (Min)*	mt/hr (Max)**	Setting (Inch)	st/hr (Min)	st/hr (Max)
Short-Head Fine	10	125	160	3/8	138	176
Short-Head Medium	13	153	188	1/2	169	207
Short-Head Medium	16	176	210	5/8	194	231
Short-Head Coarse	19	190	225	3/4	209	248
Standard Fine	22	198	240	7/8	218	265
Standard Fine	25	215	265	1	237	292
Standard Fine	32	228	286	1-1/4	251	315
Standard Medium	38	242	298	1-1/2	267	328
Standard Coarse	45	265	327	1-3/4	292	360

**Raptor R350 capacity chart**

	Setting (mm)	mt/hr (Min)*	mt/hr (Max)**	Setting (Inch)	st/hr (Min)	st/hr (Max)
Short-Head Fine	10	145	190	3/8	160	209
Short-Head Medium	13	175	230	1/2	193	254
Short-Head Medium	16	210	270	5/8	231	298
Short-Head Coarse	19	235	310	3/4	259	342
Standard Fine	22	265	340	7/8	292	375
Standard Fine	25	285	370	1	314	408
Standard Fine	32	315	410	1-1/4	347	452
Standard Medium	38	360	450	1-1/2	397	496
Standard Coarse	45	410	525	1-3/4	452	579

**Raptor R450 capacity chart**

	Setting (mm)	mt/hr (Min)*	mt/hr (Max)**	Setting (Inch)	st/hr (Min)	st/hr (Max)
Short-Head Fine	10	160	210	3/8	176	231
Short-Head Medium	13	200	260	1/2	220	287
Short-Head Medium	16	240	310	5/8	265	342
Short-Head Coarse	19	280	360	3/4	309	397
Standard Fine	22	315	400	7/8	347	441
Standard Fine	25	350	440	1	386	485
Standard Fine	32	400	500	1-1/4	441	551
Standard Medium	38	460	560	1-1/2	507	617
Standard Coarse	45	530	640	1-3/4	584	705

\*Reduction ratio 4 to 6

\*\*Reduction ratio 2 to 4

Note: figures based on BD if 1.6 t/m3 and a Cwi of 14 kWh/t

**Major dimensions**

mm [in]	A Adjustment ring max diameter	B Inside diameter of feed hopper	C Clearing stroke travel	D Height from base to top of feed hopper	E Base to bottom of oil piping	F Base to bottom of main frame hub	G Base to top of feed plate
<b>Raptor R250</b>	1,700 [66 15/16"]	953 [37 1/2"]	95 [3 3/4"]	1,560 [61 7/16"]	400 [15 3/4"]	115 [4 1/2"]	1,210 [47 5/8"]
<b>Raptor R350</b>	2,025 [79 3/4"]	1,080 [42 1/2"]	117 [4 5/8"]	1,860 [73 1/4"]	400 [15 3/4"]	107 [4 3/16"]	1,411 [55 9/16"]
<b>Raptor R450</b>	2,388 [94"]	1,308 [51 1/2"]	100 [3 15/16"]	2,026 [79 3/4"]	300 [11 13/16"]	79 [3 1/8"]	1,598 [62 15/16"]

mm [in]	Hub diameter of main frame	I Crusher centerlines to main frame flange	J Clearance required to remove countershaft assembly	K Crusher centerline end of countershaft	L Crusher centerline to countershaft housing face	M Clearance required to remove head assembly	N Clearance required to remove bowl assembly
<b>Raptor R250</b>	880 [34 5/8"]	770 [30 5/16"]	1,950 [76 3/4"]	1,185 [46 5/8"]	798 [31 7/16"]	2,360 [92 15/16"]	2,360 [92 15/16"]
<b>Raptor R350</b>	1020 [40 3/16"]	950 [37 3/8"]	2,250 [88 9/16"]	1,344 [52 15/16"]	950 [37 3/8"]	2,800 [110 1/4"]	2,800 [110 1/4"]
<b>Raptor R450</b>	1128 [44 13/32"]	1,207 [47 1/2"]	2,750 [108 1/4"]	1,642 [64 5/8"]	1,331 [52 3/8"]	3,050 [120 1/16"]	3,050 [120 1/16"]

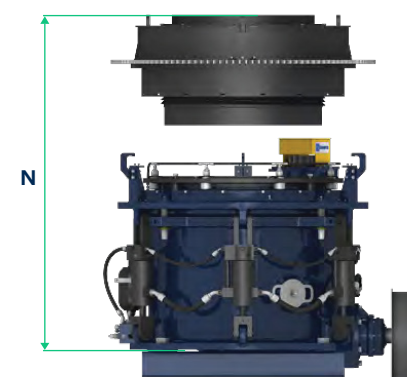
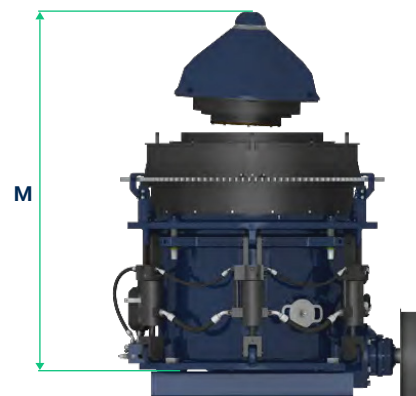
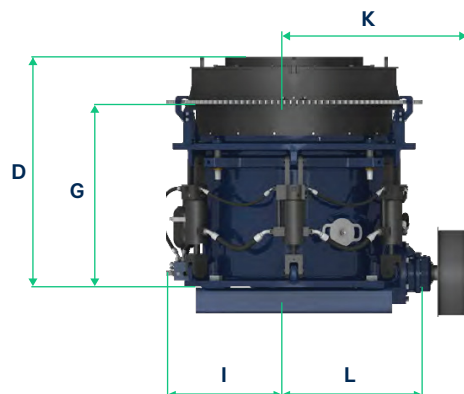
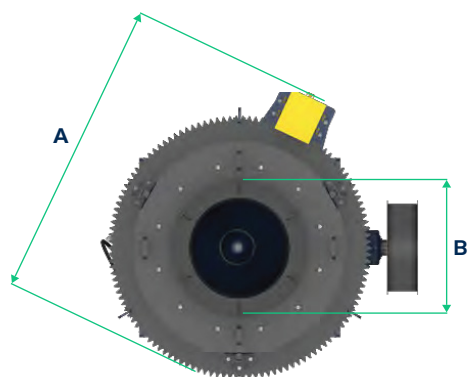



# A river rock customer story

Custom-designed liner profile delivers increased productivity with reduced wear

## Issues rooted in feed size and shape

A Raptor R250 cone crusher used to process dredged river rock was suffering from low production rates and additional hours of maintenance downtime due to high wear and frequent liner change-outs. The crusher was operating with a 13 mm (0.5 in) closed-side setting (CSS), processing a feed of 16 mm to 32 mm (0.6 in to 1.25 in).

The operator was required to close the CSS to maintain product size, which cut productivity to only 81 mtph. Additionally, the crusher was unable to hold its CSS after processing only ~15,000 tonnes, which dramatically increased the plant's recirculating load. At that point, along with the increased load, the crusher liners were only able to process an additional 10,000 tonnes before they began to generate overloading and ring bounce, requiring a liner change.

## Our evaluation

We were asked to review the operation and make recommendations to increase liner wear life and crusher tonnage, while also reducing downtime. During a site visit to analyse the operation, the mantle and bowl liner profiles were inspected and measured. By using data from the operation's new and used liners, it was determined that high wear spots in the upper portion of the chamber were caused by the round feed material (river rock) not being adequately gripped and pulled down into the chamber.

This led to the mantle liner wearing out before the bowl liner, and a resulting poor overall profile during operation

## 25,000

The liner life increased by more than 50 percent and production remained constant throughout the lifecycle. Where the previous liner profile allowed only 25,000 tonnes total per liner set.

## Increased throughput and a 50 percent better liner life

Following a review of the available standard designs, the need for a custom-designed liner profile was determined. The design, dubbed "river rock", created a longer chamber, which would lead to an improved wear profile and subsequent longer liner life. Our design widened the chamber to allow for more inter-particle breakage in the upper portion of the chamber, to reduce hot spots and utilise more crushing surface.

We expedited delivery of the new liner design to the quarry, and after installing the new "river rock" liners, our customer operated the crusher for two and a half months before replacing them. During that time, plant production increased from 81 mtph (89mtph) to approximately 91 mtph (100 tph), while holding the desired CSS, without overload or ring bounce.

## 38,000

The customer now achieves approximately 38,000 tonnes of production per set with the new liner design.

# Adding value by maximising performance

Using our knowledge as an Original Equipment Manufacturer (OEM), we ensure that the supplied parts are correct for your equipment and application. We offer cone crusher liners tailored to your needs and manufactured to increase your productivity.

## Genuine partnership in wear and spare parts

It is unavoidable that over time, parts will need to be replaced. We have certified replacement spare and wear parts on-hand to keep your Raptor running at peak performance.

- Mantle and bowl liners
- Liner accessories
- Arm guards and frame liners
- Major assemblies and components

## Mantle and bowl liners

Add value and maximise performance of your new Raptor cone crusher with our cone crusher performance liners. They're specifically designed to perform in the most demanding applications. To meet the increasing challenges of harder materials, resource scarcity and increasingly stringent product requirements – all of which lead to rising production costs – these liners address all the challenges.

For harder materials, which increase component stress throughout the machine, the performance liners reduce the peak forces transmitted into the crusher during operation. The crusher's internal components experience less stress, helping increase reliability.

The demand for equipment to help reduce the amount of waste material is growing. Our performance liners feature a more

aggressive crushing chamber profile to meet this need. This allows the material to be nipped more quickly and efficiently.

As product requirements become more stringent, you can trust that our performance liners handle the requirements of size and shape with ease. By minimising slippage during processing and increasing the number of impacts, the liners will help you achieve additional productivity.

## Ease of installation

The Raptor cone crushers R250, R350 and R450 are easy to install. The unit (crusher, lubricant and hydraulic skids) arrives onsite at your project's location on a structural frame that can be mounted to a concrete foundation or mobile unit. With the FLS machine control system it is ready to go or it can easily be connected to the plant's central control system.

## After-sales service

You receive the benefits of the FLS supply chain and 100 percent integrated unit of supplied components. You know that we will be on board with you all the way with options including:

Typical applications	Mantles	Bowls
Low-abrasion feed	SM330	SM330
Medium-abrasion feed	HM830	HM830
High-abrasion feed	XM1130*	XM1130*

\*care needs to be used with presence of steel

Choose from three standard grades of cone crusher liners, which allow you to quickly address changing ore characteristics. Our SM330 material performs well for average abrasive ore type, while more abrasive ores typically benefit from HM830 or XM1130 wear materials.

# A partner you can trust

We approach your project not as suppliers, but as partners invested in your success. We provide equipment, software and advisory services to bring your crushing operation to full potential. Understanding the ways in which your crusher lining wears is key to increasing uptime and accurately scheduling maintenance shutdowns. Our chamber scanning service provides a safe, simple, and accurate method to gauge liner wear.

## Plant performance review

Beyond providing high quality equipment and parts, we partner with you in all aspects of your plant process, including equipment loading, screening efficiency, product size needs and material handling. Our process experts assist in designing, installing, commissioning, and auditing your plant to ensure it keeps operating at peak performance. Our team will evaluate the following typical concerns and help deliver the best solution.

## Imbalanced crusher loading resulting in poor production

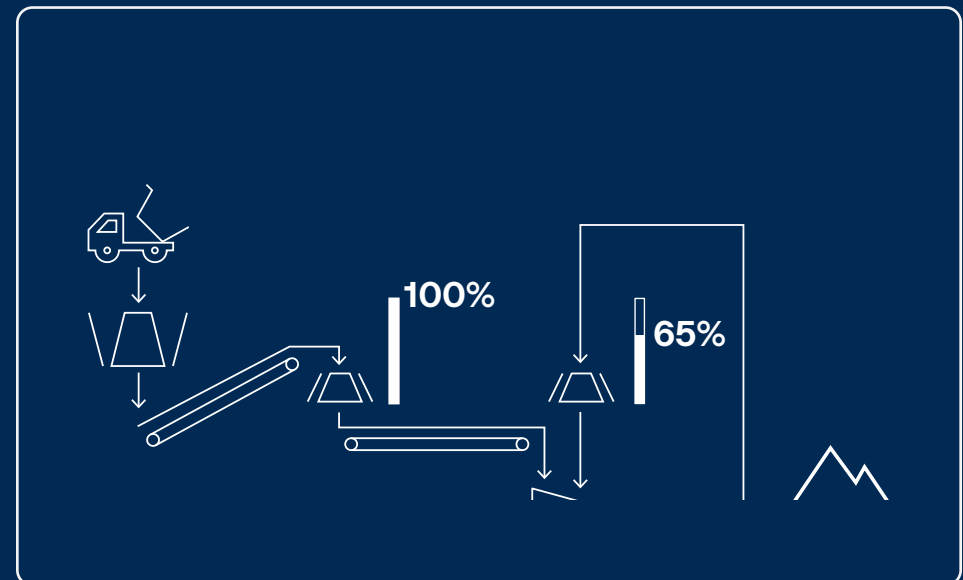

# The end result? To boost the productivity of your operations

- Product quality
- Wear part utilisation
- Equipment availability
- Profitability

Maximise your crusher liner performance with our 3D liner scanning and optimisation service. Our chamber scanner uses laser technology capable of recording up to 50 million data points of the liner profile at accuracy levels that physical measurements cannot achieve. It can easily be performed within planned maintenance and inspection schedules. Our experts compile, analyse and interpret the raw scanned data, then discuss wear life estimations, shutdown planning, and opportunity for improved operating procedures with you.

- Basic wear reporting
- Advanced wear analysis and optimisation
- Onsite technical advisory
- Crusher liner material optimisation
- Crusher liner profile optimisation

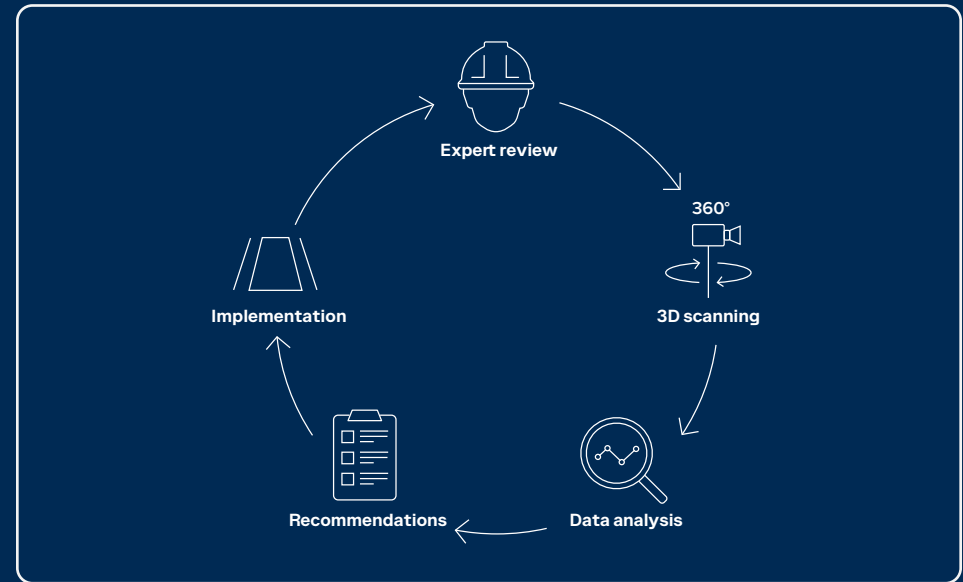

## Properly balanced crusher loading resulting in maximum production

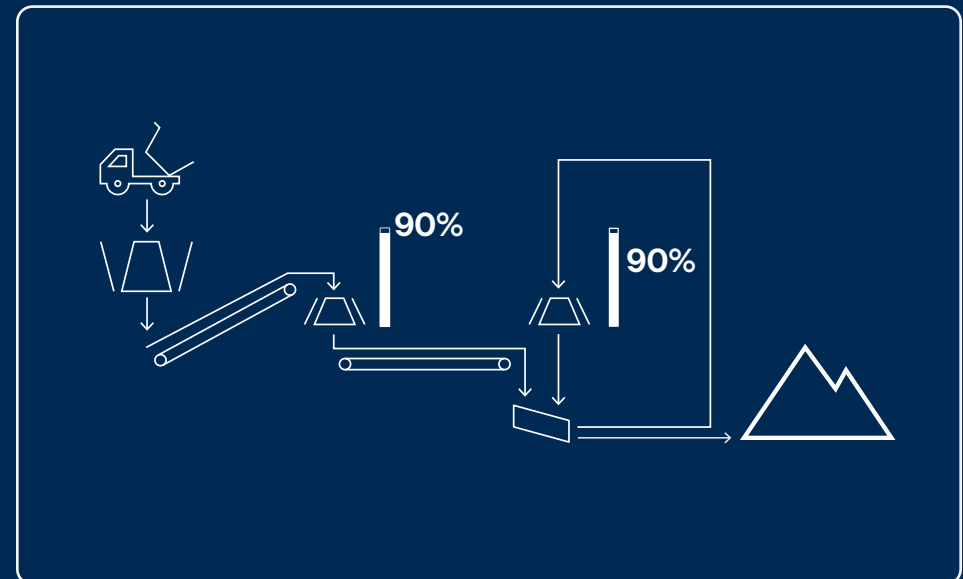

FLS is a leading, full flowsheet minerals processing supplier to the global mining industry. We deliver proven technologies and services across the lifecycle of operations, and have set targets of providing solutions for zero-emissions mining by 2030 with our MissionZero programme.

## Get in touch



[fls.pro/contact-us](https://fls.pro/contact-us)

## Follow us

 [www.linkedin.com/showcase/flsmidth-mining/](https://www.linkedin.com/showcase/flsmidth-mining/)

 [www.youtube.com/user/flsmidth](https://www.youtube.com/user/flsmidth)

Copyright ©2026 FLSmidth A/S. All rights reserved. FLSmidth and FLS are trademarks of FLSmidth A/S.  
Any information provided in brochures, datasheets, white papers, product catalogues, videos, or other materials, whether in writing, orally, electronically, online, or via download, is for general informational purposes only and may change without notice.  
FLSmidth makes no offers, representations, or warranties of any kind (express or implied) regarding the accuracy, completeness, or reliability of the information and shall not be liable for any loss or damage resulting from its use.  
FLSmidth reserves the right to alter its products without prior notice.