

Product data sheet

Specifications

SQUARE D



Branch unit, EZ Meter-Pak, 225A, 4 x 5 jaw sockets, 120/240VAC, no bypass, ringless, 800A Al busbar

EZMR114225

Product availability: Stock - Normally stocked in distribution facility

Main

Product	Meter Center Branch Unit
Current Rating	225 A
Type	Meter-Pak
Bus Rating	800 A
Number of Jaws	5 without jaw release
Number of Meter Sockets	4
Bypass Type	No bypass
Socket Type	Ringless

Complementary

Certifications	UL Listed
Busbar Material	Aluminium: busbar
Enclosure Material	Steel
Enclosure Rating	NEMA 3R
Maximum Voltage Rating	120/240 V AC
Mounting	Surface
Phase	1 phase in 1 phase out
Wire Configuration	3-wire
Height	52.00 in (1320.80 mm)
Width	17.38 in (441.45 mm)
Depth	8.09 in (205.49 mm)

Ordering and shipping details

Category	US10DE400020
Discount Schedule	0DE4
GTIN	785901333036
Returnability	Yes
Country of origin	MX

Packing Units

Unit Type of Package 1	PCE
------------------------	-----

Price is "List Price" and may be subject to a trade discount – check with your local distributor or retailer for actual price.

Nbr. of units in pkg.	1
Package 1 Height	9.400 in (23.876 cm)
Package 1 Width	19.800 in (50.292 cm)
Package 1 Length	53.000 in (134.620 cm)
Package weight(Lbs)	88.000 lb(US) (39.916 kg)
Unit Type of Package 2	PAL
Number of Units in Package 2	8
Package 2 Height	40.000 in (101.600 cm)
Package 2 Width	42.000 in (106.680 cm)
Package 2 Length	60.000 in (152.400 cm)
Package 2 Weight	704.0005 lb(US) (319.329 kg)

Contractual warranty

Warranty	18 months
-----------------	-----------



Environmental Data

Schneider Electric aims to achieve Net Zero status by 2050 through supply chain partnerships, lower impact materials, and circularity via our ongoing “Use Better, Use Longer, Use Again” campaign to extend product lifetimes and recyclability.

[Environmental Data explained >](#)

[How we assess product sustainability >](#)

Environmental footprint	
Carbon footprint (kg CO2 eq, Total Life cycle)	681
Environmental Disclosure	Product Environmental Profile

Use Better

Materials and Substances	
Packaging made with recycled cardboard	No
Packaging without single use plastic	No
EU RoHS Directive	Compliant with Exemptions
REACH Regulation	REACH Declaration
California proposition 65	WARNING: This product can expose you to chemicals including: Lead and lead compounds, which is known to the State of California to cause cancer and birth defects or other reproductive harm. For more information go to www.P65Warnings.ca.gov

Use Again

Repack and remanufacture	
Circularity Profile	No need of specific recycling operations
Take-back	No

Technical Illustration

Dimensions

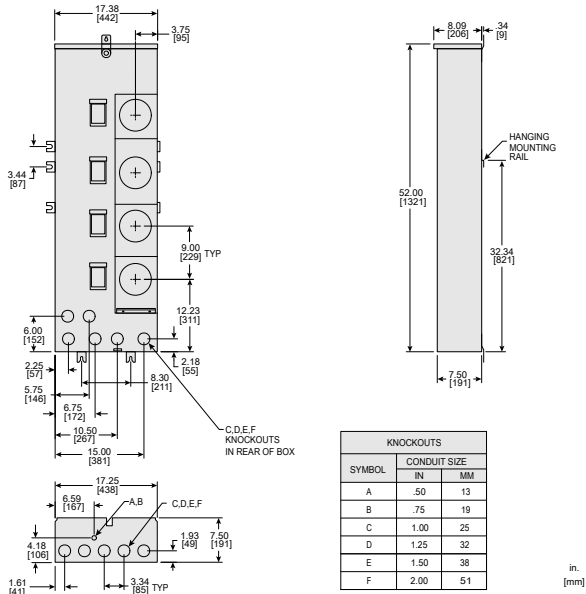

ALL DIMENSIONS ARE APPROXIMATE.
REFER TO TECHNICAL DRAWINGS AND DOCUMENTATION FOR COMPLETE INFORMATION.

in.
[mm]

Technical Illustration

Wiring diagram

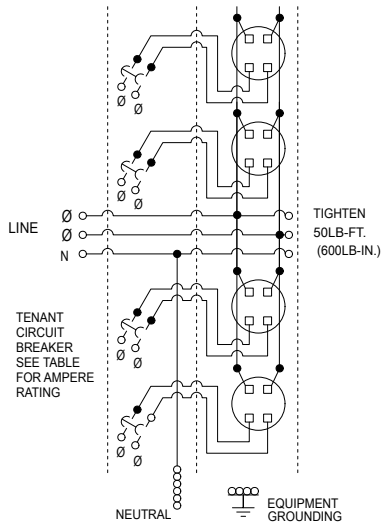

EZM114225
EZMR114225
EZMH114225

REFER TO TECHNICAL DRAWINGS AND DOCUMENTATION FOR COMPLETE INFORMATION.