

ALUMINUM COMBINATION CONDUIT BODIES WITH COVER AND GASKET

FOR THREADED RIGID CONDUIT, IMC AND EMT

APPLICATION

Used with threaded rigid conduit, IMC, and EMT for providing access to the interior of a conduit system for pulling, splicing, inspection and maintenance.

FEATURES

- Assembled with slotted/ Robertson combination screws.
- Assembled with neoprene gasket and stamped cover.
- Tapered threaded hubs (NPT).
- Die cast from high-strength, corrosion and weather resistant, copper-free aluminum alloy.
- Flat back design for easy mounting close to walls.
- Suitable for use in concrete.

STANDARD MATERIALS

Die cast/Copper-free Aluminum

STANDARD FINISH

Aluminum Enameled



TYPE C1CA

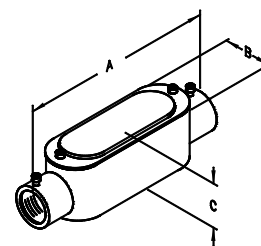

CATALOG NUMBER	TRADE SIZE	DIM A	DIM B	DIM C	MAX WIRE SIZE	VOL. CU.IN.	UNIT PACK	MASTER PACK	LBS. / 100 PCS.	UPC #
C Type										
C1CA	1/2"	4.69	1.38	1.56	N/A	4.35	10	50	28	64401
C2CA	3/4"	5.50	1.56	1.75	3 #6 AWG	7.30	10	50	41	64402
C3CA	1"	6.48	1.88	2.13	3 #4 AWG	12.20	5	25	56	64403
C4CA	1-1/4"	8.31	2.50	2.75	3 #2 AWG	33.50	-	10	101	64404
C5CA	1-1/2"	8.38	2.50	2.75	3 #1/0 AWG	33.50	-	10	104	64405
C6CA	2"	10.31	3.38	3.63	3 #4/0 AWG	69.50	-	5	220	64406



TYPE LB1CA

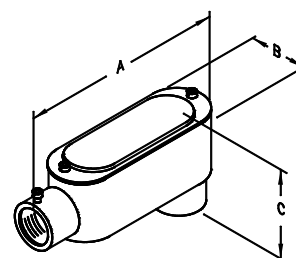

CATALOG NUMBER	TRADE SIZE	DIM A	DIM B	DIM C	MAX WIRE SIZE	VOL. CU.IN.	UNIT PACK	MASTER PACK	LBS. / 100 PCS.	UPC #
LB Type										
LB1CA	1/2"	4.31	1.31	2.44	N/A	4.35	10	50	24	64101
LB2CA	3/4"	5.06	1.56	2.69	3 #6 AWG	7.25	10	50	37	64102
LB3CA	1"	5.87	1.75	3.00	3 #4 AWG	12.20	5	25	46	64103
LB4CA	1-1/4"	7.81	2.50	3.69	3 #2 AWG	32.30	-	10	98	64104
LB5CA	1-1/2"	7.81	2.50	3.69	3 #2 AWG	33.80	-	10	91	64105
LB6CA	2"	10.06	3.12	4.56	3 #4/0 AWG	71.20	-	5	222	64106

ALUMINUM COMBINATION CONDUIT BODIES WITH COVER AND GASKET

FOR THREADED RIGID CONDUIT, IMC AND EMT

APPLICATION

Used with threaded rigid conduit, IMC, and EMT for providing access to the interior of a conduit system for pulling, splicing, inspection and maintenance.

FEATURES

- Assembled with slotted/ Robertson combination screws.
- Assembled with neoprene gasket and stamped cover.
- Tapered threaded hubs (NPT).
- Die cast from high-strength, corrosion and weather resistant, copper-free aluminum alloy.
- Flat back design for easy mounting close to walls.
- Suitable for use in concrete.

STANDARD MATERIALS

Die cast/Copper-free Aluminum

STANDARD FINISH

Aluminum Enameled

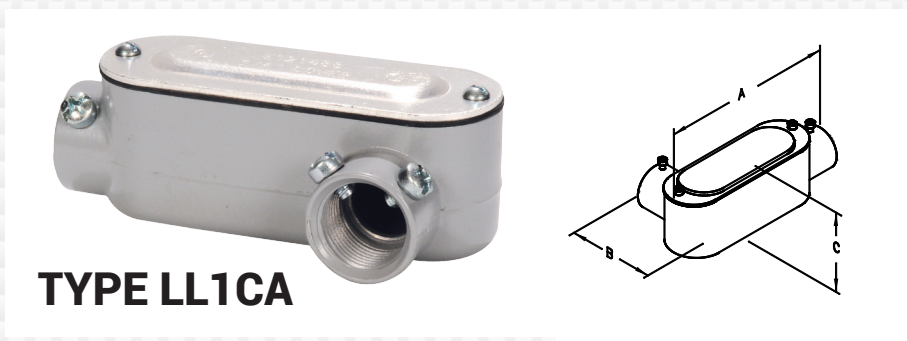

TYPE LL1CA

CATALOG NUMBER	TRADE SIZE	DIM A	DIM B	DIM C	MAX WIRE SIZE	VOL. CU.IN.	UNIT PACK	MASTER PACK	LBS. / 100 PCS.	UPC #
LL Type										
LL1CA	1/2"	4.31	2.06	1.63	N/A	4.35	10	50	25	64201
LL2CA	3/4"	5.06	2.25	1.88	3 #6 AWG	7.30	10	50	37	64202
LL3CA	1"	5.87	2.63	2.13	3 #4 AWG	12.20	5	25	45	64203
LL4CA	1-1/4"	7.81	3.63	2.75	3 #2 AWG	35.80	-	10	98	64204
LL5CA	1-1/2"	7.81	3.63	2.75	3 #1/0 AWG	35.80	-	10	92	64205
LL6CA	2"	10.06	4.44	3.63	3 #4/0 AWG	69.70	-	5	245	64206



TYPE LR1CA

CATALOG NUMBER	TRADE SIZE	DIM A	DIM B	DIM C	MAX WIRE SIZE	VOL. CU.IN.	UNIT PACK	MASTER PACK	LBS. / 100 PCS.	UPC #
LR Type										
LR1CA	1/2"	4.31	2.06	1.63	N/A	4.35	10	50	23	64301
LR2CA	3/4"	5.06	2.25	1.88	3 #6 AWG	7.30	10	50	38	64302
LR3CA	1"	5.87	2.63	2.13	3 #4 AWG	12.20	5	25	49	64303
LR4CA	1-1/4"	7.81	3.63	2.75	3 #2 AWG	35.80	-	10	98	64304
LR5CA	1-1/2"	7.81	3.63	2.75	3 #1/0 AWG	35.80	-	10	94	64305
LR6CA	2"	10.06	4.44	3.63	3 #4/0 AWG	69.70	-	5	254	64306

ALUMINUM COMBINATION CONDUIT BODIES WITH COVER AND GASKET

FOR THREADED RIGID CONDUIT, IMC AND EMT

APPLICATION

Used with threaded rigid conduit, IMC, and EMT for providing access to the interior of a conduit system for pulling, splicing, inspection and maintenance.

FEATURES

- Assembled with slotted/ Robertson combination screws.
- Assembled with neoprene gasket and stamped cover.
- Tapered threaded hubs (NPT).
- Die cast from high-strength, corrosion and weather resistant, copper-free aluminum alloy.
- Flat back design for easy mounting close to walls.
- Suitable for use in concrete.

STANDARD MATERIALS

Die cast/Copper-free Aluminum

STANDARD FINISH

Aluminum Enameled

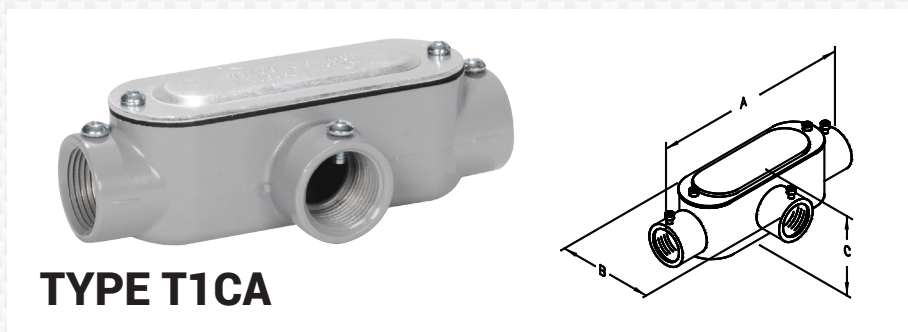

TYPE T1CA

CATALOG NUMBER	TRADE SIZE	DIM A	DIM B	DIM C	MAX WIRE SIZE	VOL. CU.IN.	UNIT PACK	MASTER PACK	LBS. / 100 PCS.	UPC #
T Type										
T1CA	1/2"	4.75	2.06	1.63	N/A	4.35	10	50	23	64501
T2CA	3/4"	5.56	2.25	1.88	3 #6 AWG	7.25	10	50	38	64502
T3CA	1"	6.44	2.63	2.13	3 #4 AWG	12.20	5	25	53	64503
T4CA	1-1/4"	8.25	3.56	2.75	3 #2 AWG	33.10	-	10	100	64504
T5CA	1-1/2"	8.38	3.56	2.75	3 #1/0 AWG	33.10	-	10	98	64505
T6CA	2"	10.69	4.38	3.63	3 #4/0 AWG	67.00	-	5	265	64506