

Die cast aluminum for thru-wall or conduit end floodlight mounting. Three 1/2" threaded holes. Side opening cover for easy access and splicing. 1/2" thru wall tapped hub.

Color: Natural

Weight: 0.4 lbs

Project:

Type:

Prepared By:

Date:

Technical Specifications

Compliance

UL Listed:

Suitable for wet locations

Other

Outlet Box Construction:

Precision die cast aluminum

Buy American Act Compliance:

RAB values USA manufacturing! Upon request, RAB may be able to manufacture this product to be compliant with the Buy American Act (BAA). Please contact customer service to request a quote for the product to be made BAA compliant.

Construction

Outlet Box Mounting Lugs:

16 gauge corrosion protected steel with Phillips Flat head mounting screws

Ground Screw:

#10-24 Green corrosion protected steel slotted hex washer head screw provided in pre-tapped hole

Dimensions

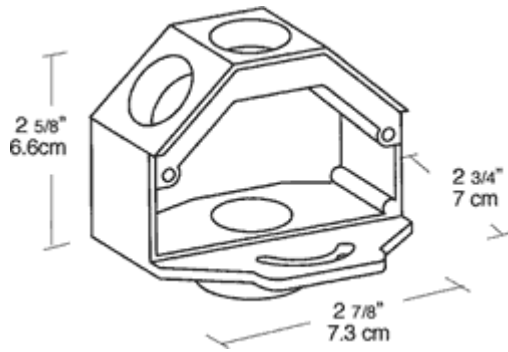

Features

- Die cast aluminum
- Three 1/2" threaded holes
- 1/2" thru wall tapped hub