

# Modicon M171 Performance Logic Controller

## Hardware Guide

EIO0000002030.05  
05/2024



---

## Legal Information

The information provided in this document contains general descriptions, technical characteristics and/or recommendations related to products/solutions.

This document is not intended as a substitute for a detailed study or operational and site-specific development or schematic plan. It is not to be used for determining suitability or reliability of the products/solutions for specific user applications. It is the duty of any such user to perform or have any professional expert of its choice (integrator, specifier or the like) perform the appropriate and comprehensive risk analysis, evaluation and testing of the products/solutions with respect to the relevant specific application or use thereof.

The Schneider Electric brand and any trademarks of Schneider Electric SE and its subsidiaries referred to in this document are the property of Schneider Electric SE or its subsidiaries. All other brands may be trademarks of their respective owner.

This document and its content are protected under applicable copyright laws and provided for informative use only. No part of this document may be reproduced or transmitted in any form or by any means (electronic, mechanical, photocopying, recording, or otherwise), for any purpose, without the prior written permission of Schneider Electric.

Schneider Electric does not grant any right or license for commercial use of the document or its content, except for a non-exclusive and personal license to consult it on an "as is" basis.

Schneider Electric reserves the right to make changes or updates with respect to or in the content of this document or the format thereof, at any time without notice.

**To the extent permitted by applicable law, no responsibility or liability is assumed by Schneider Electric and its subsidiaries for any errors or omissions in the informational content of this document, as well as any non-intended use or misuse of the content thereof.**



---

# TABLE OF CONTENTS



---

<b>CHAPTER</b>	<b>1. Introduction</b>	<b>13</b>
	1.1. General description of Modicon M171 Performance	13
	1.1.1. Modicon M171 Performance offer	13
<b>CHAPTER</b>	<b>2. Mechanical installation</b>	<b>16</b>
	2.1. Before Starting	16
	2.2. Disconnecting Power	16
	2.3. Programming Considerations	17
	2.4. Operating Environment	17
	2.5. Installation Considerations	17
	2.6. TM171PDM27● / TM171PBM27R / TM171EP●●R installation	19
	2.7. Assembling the TM171A●●●● Communication Modules	21
	2.8. Assembling the M171 Performance Flush or TM171DGRP	22
	2.8.1. Panel mounting	22
	2.8.2. Accessories for Wall mounting	23
<b>CHAPTER</b>	<b>3. Electrical connections</b>	<b>24</b>
	3.1. Wiring Best Practices	24
	3.1.1. Wiring Guidelines	24
	3.1.2. Rules for Removable Screw Terminal Block	25
	3.1.3. Protecting Outputs from Inductive Load Damage	26
	3.1.4. Special handling considerations	28
	3.1.5. Analog Inputs-Probes	28
	3.1.6. Serial connections	28
	3.2. Wiring diagrams	31
	3.2.1. Modicon M171P wiring diagram	31
	3.2.2. Modicon M171EP14R wiring diagram	33
	3.2.3. Examples of analog input connection (M171 Performance only)	34
	3.2.4. M171 Performance / M171 Display Graphic connection	38
	3.2.5. M171 Performance Flush TM171PFE03 and TM171PFE03HR connection	39
	3.3. M171 Performance protocol connectivity	41
	3.3.1. Example: CAN (Field) network connection	41

3.3.2. Example: CAN connection (Network).....	42
3.3.3. Example: RS485 connection (Field).....	43
3.3.4. Example: RS485 connection with the Modicon M171O network.....	44
<b>3.4. M171 Performance Flush protocol connectivity .....</b>	<b>45</b>
3.4.1. Example: RS485 connection (Field).....	45
3.4.2. Example: CAN connection .....	45
3.4.3. Example: RS485 connection with the Modicon M171O network.....	46
3.4.4. Example: CAN network connection.....	47
<b>3.5. TM171A●●●● Communication Modules .....</b>	<b>48</b>
3.5.1. Communication Modules compatible with M171 and M172.....	48
3.5.2. Communication Modules exclusively compatible with M171.....	49
3.5.3. TM171ARS232.....	52
3.5.4. TM171AETH / TM171AETHRS485.....	54
3.5.5. Example: BACnet / IP.....	55
3.5.6. TM171AMB.....	58
3.5.7. TM171ARS485 / TM171AETHRS485 .....	59
3.5.8. TM171ACAN .....	60
3.5.9. TM171APBUS .....	61
3.5.10. TM171ALON.....	62
<b>3.6. Ethernet connection (for M171 Performance Flush) .....</b>	<b>63</b>

## **CHAPTER 4. Technical data ..... 65**

<b>4.1. General specifications.....</b>	<b>66</b>
4.1.1. M171 Performance 27 I/Os / TM171EP14R.....	66
4.1.2. M171 Flush.....	67
<b>4.2. I/O features .....</b>	<b>68</b>
4.2.1. M171 Performance I/O features .....	68
4.2.2. M171EP14R Performance I/O features.....	70
4.2.3. M171 Performance Flush I/O features .....	71
<b>4.3. Display .....</b>	<b>72</b>
4.3.1. M171 Performance Display Graphic / M171 Performance Flush display.....	72
<b>4.4. Serials .....</b>	<b>72</b>
4.4.1. TM171A●●●● Communication Module .....	73
<b>4.5. Power supply.....</b>	<b>74</b>

---

	4.6. Mechanical dimensions.....	74
<b>CHAPTER</b>	<b>5. M171 Performance User Interface .....</b>	<b>76</b>
	5.1. Keys and LEDs .....	76
	5.2. First power on .....	77
<b>CHAPTER</b>	<b>6. M171 Performance Display Graphic user interface.....</b>	<b>78</b>
	6.1. Keys and LEDs .....	78
	6.2. First power on .....	79
	6.3. DIAGNOSTICS menu .....	80
	6.3.1. BIOS parameters.....	80
	6.3.2. HMI Management.....	80
	6.4. Remote interface.....	80
	6.4.1. Language .....	80
	6.4.2. ⬆⬇ .....	80
	6.4.3. HMI Management.....	81
<b>CHAPTER</b>	<b>7. M171 Performance Flush user interface.....</b>	<b>82</b>
	7.1. Keys and LEDs .....	82
	7.2. First power on .....	83
	7.3. DIAGNOSTIC menu .....	84
	7.3.1. BIOS parameters.....	84
	7.3.2. HMI management.....	84
	7.3.3. Probe values .....	84
	7.3.4. Date and time .....	85
	7.4. Remote interface.....	86
	7.4.1. Language .....	86
	7.4.2. ⬆⬇ .....	86
	7.4.3. HMI sel .....	86
	7.4.4. COM Setting.....	87
	7.4.5. HMI Management.....	87
<b>CHAPTER</b>	<b>8. Physical I/O and ports configuration .....</b>	<b>88</b>
	8.1. Analog inputs.....	89
	8.1.1. Analog inputs configuration for M171 Performance .....	89
	8.1.2. Analog inputs configuration for M171EP14R.....	90
	8.1.3. Analog inputs configuration for M171 Performance Flush.....	92

---

8.2. Analog outputs configuration for M171 Performance .....	93
8.3. Digital inputs configuration for M171 Performance .....	93
8.4. Digital outputs configuration for M171 Performance .....	94
8.5. Ports configuration for M171 Performance using DipSwitch .....	94
8.5.1. TM171PDM27• DipSwitch .....	95
8.5.2. TM171PBM27R DipSwitch .....	96
8.5.3. TM171EP27R expansion DipSwitch .....	100
8.5.4. TM171EP14R expansion DipSwitch .....	102
<b>CHAPTER 9. Parameters .....</b>	<b>103</b>
9.1. M171 Performance parameter table .....	103
9.1.1. TM171PDM27• / TM171PBM27R / TM171EP27R parameters .....	104
9.1.2. M171EP14R parameters .....	115
9.1.3. M171 Performance Flush parameters .....	120
<b>CHAPTER 10. Programming of the TM171EP14R .....</b>	<b>129</b>

---

## SAFETY INFORMATION



---

### Important Information

Read these instructions carefully, and look at the equipment to become familiar with the device before trying to install, operate, service, or maintain it. The following special messages may appear throughout this documentation or on the equipment to inform of potential hazards or to call attention to information that clarifies or simplifies a procedure.



The addition of this symbol to a 'Danger' or 'Warning' safety label indicates that an electrical hazard exists, which will result in personal injury if the instructions are not followed.



This is the safety alert symbol. It is used to alert you to potential personal injury hazards. Obey all safety messages that follow this symbol to avoid possible injury or death.

#### **DANGER**

**DANGER** indicates a hazardous situation which, if not avoided, **will result** in death or serious injury.

#### **WARNING**

**WARNING** indicates a hazardous situation which, if not avoided, **could result** in death or serious injury.

#### **CAUTION**

**CAUTION** indicates a hazardous situation which, if not avoided, **could result** in minor or moderate injury.

#### **NOTICE**

**NOTICE** is used to address practices not related to physical injury.

#### PLEASE NOTE

Electrical equipment should be installed, operated, serviced, and maintained only by qualified personnel.

No responsibility is assumed by Schneider Electric for any consequences arising out of the use of this material.

A qualified person is one who has skills and knowledge related to the construction and operation of electrical equipment and its installation, and has received safety training to recognize and avoid the hazards involved.

#### Qualified Personnel

Only appropriately trained persons who are familiar with and understand the contents of this manual and all other pertinent product documentation are authorized to work on and with this product.

The qualified person must be able to detect possible hazards that may arise from parameterization, modifying parameter values and generally from mechanical, electrical, or electronic equipment. The qualified person must be familiar with the standards, provisions, and regulations for the prevention of industrial accidents, which they must observe when designing and implementing the system.

---

## Permitted use

This product is used to control HVAC-related and pumping applications.

For safety reasons, the device must be installed and used in accordance with the instructions provided. In particular, parts carrying dangerous voltages must not be accessible under normal conditions.

The device must be adequately protected from water and dust with regard to the application, and must only be accessible using tools (with the exception of the front panel).

The device is also suitable for use in household and commercial refrigeration appliances and/or similar equipment and has been tested for safety aspects in accordance with the harmonized European reference standards.

## Prohibited use

Any use other than that expressed above under Permitted use is strictly prohibited.

The relay contacts supplied are of an electromechanical type and subject to wear. Functional safety protection devices, specified in international or local standards, must be installed externally to this device.

## Liability and residual risks

Schneider Electric liability is limited to the proper and professional use of this product under the guidelines contained in the present and other supporting documents, and does not extend to damages caused by (but not limited to):

- Unspecified installation/use and, in particular, in contravention of the safety requirements of established legislation or specified in this document;
- Use on equipment which does not provide adequate protection against electrocution, water and dust in the actual installation conditions;
- Use on equipment which allow access to dangerous parts without the aid of a keyed or tooled locking mechanism;
- Installation/use on equipment which does not comply with established legislation and standards.

## Disposal



The appliance (or the product) must be disposed of separately in compliance with the local standards in force on waste disposal.

## Product Related Information

### DANGER

#### HAZARD OF ELECTRIC SHOCK, EXPLOSION OR ARC FLASH

- Disconnect all power from all equipment including connected devices prior to removing any covers or doors, or installing or removing any accessories, hardware, cables, or wires.
- Always use a properly rated voltage sensing device to confirm the power is removed.
- Replace and secure all covers, accessories, hardware, cables, and wires and confirm that a proper ground connection exists before applying power to the unit.
- Use only the specified voltage when operating this equipment and any associated products.

**Failure to follow these instructions will result in death or serious injury.**

This equipment has been designed to operate outside of any hazardous location.  
Only install this equipment in zones known to be free of hazardous atmosphere.

### DANGER

#### POTENTIAL FOR EXPLOSION

Install and use this equipment in non-hazardous locations only.

**Failure to follow these instructions will result in death or serious injury.**

### WARNING

#### LOSS OF CONTROL

- The designer of any control scheme must consider the potential failure modes of control paths and, for certain critical control functions, provide a means to achieve a safe state during and after a path failure. Examples of critical control functions are emergency stop and overtravel stop, power outage and restart.
- Separate or redundant control paths must be provided for critical control functions.
- System control paths may include communication links. Consideration must be given to the implications of unanticipated transmission delays or failures of the link.
- Observe all accident prevention regulations and local safety guidelines.<sup>(1)</sup>
- Each implementation of this equipment must be individually and thoroughly tested for proper operation before being placed into service.

**Failure to follow these instructions can result in death, serious injury, or equipment damage.**

(1) For additional information, refer to NEMA ICS 1.1 (latest edition), "Safety Guidelines for the Application, Installation, and Maintenance of Solid State Control" and to NEMA ICS 7.1 (latest edition), "Safety Standards for Construction and Guide for Selection, Installation and Operation of Adjustable-Speed Drive Systems" or their equivalent governing your particular location.

### WARNING

#### UNINTENDED EQUIPMENT OPERATION

- Only use software approved by Schneider Electric for use with this equipment.
- Update your application program every time you change the physical hardware configuration.

**Failure to follow these instructions can result in death, serious injury, or equipment damage.**

---

## ABOUT THE BOOK



---

### Document Scope

This document describes the **Modicon M171 performance logic controllers** and accessories including installation and wiring information.

Use this document to:

- Install and operate your **Modicon M171 Performance logic controller**.
- Connect the **Modicon M171 Performance logic controller** to a programming device equipped with **EcoStruxure Machine Expert HVAC** software.
- Interface the **Modicon M171 Performance logic controller** with I/O expansion modules, HMI and other devices.
- Familiarize yourself with the **Modicon M171 Performance logic controller** features.

NOTE: Read and understand this document and the related documents before installing, operating, or maintaining your controller.

### Validity Note

This document has been updated for the release of EcoStruxure Machine Expert - HVAC V1.6.0. The characteristics of the products described in this document are intended to match the characteristics that are available on [www.se.com](http://www.se.com). As part of our corporate strategy for constant improvement, we may revise the content over time to enhance clarity and accuracy. If you see a difference between the characteristics in this document and the characteristics on [www.se.com](http://www.se.com), consider [www.se.com](http://www.se.com) to contain the latest information.

### Related Documents

Title of documentation	Reference number
Modicon M172 Performance Logic Controller, Hardware User Guide	EIO0000002015 (ENG)
Modicon M171 Optimized Logic Controller, Hardware User Guide	EIO0000002032 (ENG)
Modicon M171 Electronic Expansion Valve Drivers, User Guide	EIO0000002034 (ENG)
EcoStruxure Machine Expert HVAC Software, Programming Guide	EIO0000002036 (ENG)
EcoStruxure Machine Expert HVAC HVAC&R Function Library, User Guide	EIO0000002057 (ENG)
TM172 Performance 28/42 IO Isolated Instruction Sheet	PHA83703
TM172 Performance 28/42 IO Instruction Sheet	NH87740
TM171 Performance 27 IO Instruction Sheet	EAV96004
TM171 Performance Flush 3 IO Instruction Sheet	EAV96006
TM171 Performance Communication Instruction Sheet	EAV96007
TM171 Performance Display Instruction Sheet	EAV96014

You can download these technical publications and other technical information from our website at:

[www.se.com](http://www.se.com)

---

## Cybersecurity

For information on cybersecurity go to Recommended Cybersecurity Best Practices.

## Information on Non-Inclusive Terminology

As part of a group of responsible, inclusive companies, we are updating our communications and products that contain non-inclusive terminology. Until we complete this process, however, our content may still contain standardized industry terms that may be deemed inappropriate by our customers.

---

# CHAPTER 1

## Introduction

---

### 1.1. General description of Modicon M171 Performance

The **Modicon M171P** is a **Schneider Electric** range of programmable controller, suitable for managing a wide range of HVAC/R and many other applications, from the simplest to the most complex.

In this manual, the photos and drawings are intended to show the **Modicon M171 Performance** programmable controller (and other Modicon devices) and are for illustrative purposes only. The relative sizes and proportions may not be indicative of actual dimensions nor to scale. In addition, any wiring diagrams or electrical schematics are to be considered as simplified renditions and not literal representations thereof.

#### 1.1.1. Modicon M171 Performance offer

The **Modicon M171P** offer is made of:

- **M171 Performance**
- **M171 Performance Display Graphic**
- **M171 Performance Flush**

References	Description
TM171PDM27R	M171 Performance Display 27 I/Os, Modbus
TM171PDM27S	M171 Performance Display 27 I/Os Modbus, 2 SSR
TM171PBM27R	M171 Performance Blind 27 I/Os, Modbus
TM171EP27R	M171 Performance expansion 27 I/Os
TM171EP14R	M171 Performance expansion 14 I/Os
TM171DGRP	M171 Performance Display Graphic
TM171PFE03	M171 Performance Flush 3 I/Os, MB & BACnet
TM171PFE03	M171 Performance Flush 3 I/Os, MB & BACnet
TM171PFE03HR	M171 Performance Flush 3 I/Os RH, MB & BACnet

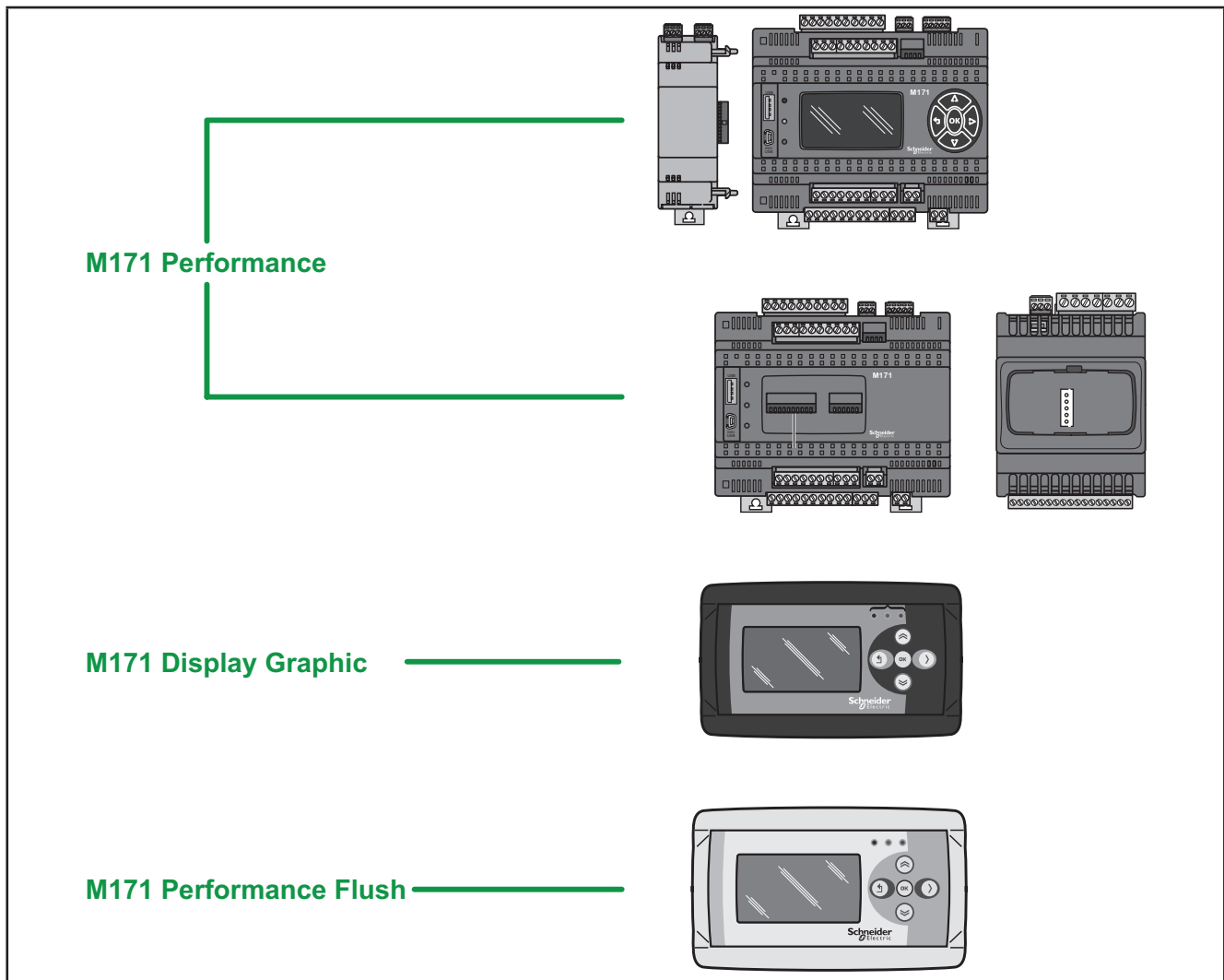

Fig. 1. Modicon M171P

**M171 Performance** delivers performance in terms of memory, connectivity and user interface as well as straightforward programming, maintenance and servicing.

The references are available as 8DIN rail-mounted versions, which saves time in terms of wiring. The 8DIN format provides extra flexibility and easy installation.

A wide range of 2DIN rail mounted Communication Modules allow integration with industrial systems, BMS and Ethernet networks.

Lastly, ratiometric pressure sensors and displays can also be connected with no need for further serial interfaces.

**M171 Performance Flush** can be used as a system controller, with gateway functions; used in combination with the **M171 Performance** and the **Modicon M1710** or third-party controllers, it delivers performance in terms of memory, connectivity and user interface as well as straightforward programming, maintenance and servicing.

**M171 Performance Flush** is designed for panel mounting, and can also be wall-mounted using a special backplate, available as an accessory.

**M171 Performance Flush** can be used to:

- manage a local menu created with the **EcoStruxure Machine Expert HVAC** User Interface;
- manage up to 10 remote menus, created with the **EcoStruxure Machine Expert HVAC** User Interface and uploaded from the respective **M171 Performance** devices connected to the network;
- share network variables (binding).

---

In association with the **Modicon M171P** hardware, there is also the **EcoStruxure Machine Expert HVAC** development tool to program and customize new programs for many HVAC- and pumping-related applications.

The use of several different programming languages in accordance with IEC61131-3 regulations makes it possible to develop new algorithms or programs, which can then be uploaded to the **Modicon M171P** modules via PC or (only for DIN rail mounted Performance controllers) USB memory key.

## Web functionalities

The **Modicon M171 Performance** also features web functionalities, offering makers of machinery and systems integrators remote access. Having a web-based connection in machines reduces support and maintenance by minimizing call-out charges. End users also benefit, as they can monitor their own systems both locally and from distance, using the graphics interface of any browser.

Main web functionalities

- Web-based access.
- Remote reading and support.
- Local and remote system control, including alarms management.
- Preventive and predictive maintenance.
- Email alarm alerts.

Care must be taken and provisions made for use of this product as a control device to avoid inadvertent consequences of commanded machine operation, controller state changes, or alteration of data memory or machine operating parameters.

### **WARNING**

#### **UNINTENDED EQUIPMENT OPERATION**

- Configure and install the mechanism that enables the remote HMI local to the machine, so that local control over the machine can be maintained regardless of the remote commands sent to the application.
- You must have a complete understanding of the application and the machine before attempting to control the application remotely.
- Take the precautions necessary to assure that you are operating remotely on the intended machine by having clear, identifying documentation within the application and its remote connection.

**Failure to follow these instructions can result in death, serious injury, or equipment damage.**

---

## CHAPTER 2

### Mechanical installation

---

#### 2.1. Before Starting

Read and understand this chapter before beginning the installation of your system. The use and application of the information contained herein require expertise in the design and programming of automated control systems. Only you, the user, machine builder or integrator, can be aware of all the conditions and factors present during installation and setup, operation, and maintenance of the machine or process, and can therefore determine the automation and associated equipment and the related safeties and interlocks which can be effectively and properly used. When selecting automation and control equipment, and any other related equipment or software, for a particular application, you must also consider any applicable local, regional or national standards and/or regulations. Pay particular attention in conforming to any safety information, different electrical requirements, and normative standards that would apply to your machine or process in the use of this equipment.

#### **WARNING**

##### **REGULATORY INCOMPATIBILITY**

Be sure that all equipment applied and systems designed comply with all applicable local, regional and national regulations and standards.

**Failure to follow these instructions can result in death, serious injury, or equipment damage.**

#### 2.2. Disconnecting Power

All options and modules should be assembled and installed before installing the control system on a mounting rail, into a panel door or onto a mounting surface. Remove the control system from its mounting rail, mounting plate or panel before disassembling the equipment.

#### **DANGER**

##### **HAZARD OF ELECTRIC SHOCK, EXPLOSION OR ARC FLASH**

- Disconnect all power from all equipment including connected devices prior to removing any covers or doors, or installing or removing any accessories, hardware, cables, or wires.
- Always use a properly rated voltage sensing device to confirm the power is removed.
- Replace and secure all covers, accessories, hardware, cables, and wires and confirm that a proper ground connection exists before applying power to the unit.
- Use only the specified voltage when operating this equipment and any associated products.

**Failure to follow these instructions will result in death or serious injury.**

---

## 2.3. Programming Considerations

The products described in this manual have been designed and tested using Schneider Electric programming, configuration and maintenance software products.

### WARNING

#### UNINTENDED EQUIPMENT OPERATION

- Only use software approved by Schneider Electric for use with this equipment.
- Update your application program every time you change the physical hardware configuration.

**Failure to follow these instructions can result in death, serious injury, or equipment damage.**

## 2.4. Operating Environment

This equipment has been designed to operate outside of any hazardous location. Only install this equipment in zones known to be free of a hazardous atmosphere.

### DANGER

#### POTENTIAL FOR EXPLOSION

Install and use this equipment in non-hazardous locations only.

**Failure to follow these instructions will result in death or serious injury.**

### WARNING

#### UNINTENDED EQUIPMENT OPERATION

Install and operate this equipment according to the conditions described in the General Specifications.

**Failure to follow these instructions can result in death, serious injury, or equipment damage.**

## 2.5. Installation Considerations

### WARNING

#### UNINTENDED EQUIPMENT OPERATION

- Use appropriate safety interlocks where personnel and/or equipment hazards exist.
- Install and operate this equipment in an enclosure appropriately rated for its intended environment.
- Power line and output circuits must be wired and fused in compliance with local and national regulatory requirements for the rated current and voltage of the particular equipment.
- Do not use this equipment in safety-critical machine functions.
- Do not disassemble, repair, or modify this equipment.
- Do not connect any wiring to reserved, unused connections, or to connections designated as No Connection (N.C.).
- Do not mount devices in extremely damp and/or dirt-laden areas.

**Failure to follow these instructions can result in death, serious injury, or equipment damage.**

**NOTE:** JDYX2 or JDYX8 fuse types are UL-recognized and CSA approved.

For mechanical dimensions, see [4.6. Mechanical dimensions on page 74](#).

The **Modicon M171P** logic controllers are intended for DIN rail mounting, panel mounting or wall mounting.

---

Care must be taken to avoid damage from electrostatic sources when handling this equipment. In particular exposed connectors and, in some cases, exposed printed circuit boards are vulnerable to electrostatic discharge.

**⚠ WARNING**

**UNINTENDED EQUIPMENT OPERATION DUE TO ELECTROSTATIC DISCHARGE DAMAGE**

- Keep equipment in the protective conductive packaging until you are ready to install the equipment.
- Only install equipment in approved enclosures and / or locations that prevent casual access and provide electrostatic discharge protection.
- Use a conductive wrist strap or equivalent field force protective device attached to an earth ground when handling sensitive equipment.
- Always discharge yourself by touching a grounded surface or approved antistatic mat before handling the equipment.

**Failure to follow these instructions can result in death, serious injury, or equipment damage.**

## 2.6. TM171PDM27● / TM171PBM27R / TM171EP●●R installation

The equipment is intended for 8DIN rail mounting (refer to **Fig. 2 on page 19** and **Fig. 3 on page 20**). For DIN rail installation, follow the steps described below:

1. Move the two clip-on locks to their standby position (use a screwdriver to press against the relative compartments).
2. Install the device on the DIN rail.
3. Press on the clip-on locks to put them into the locked position.
4. Once assembled on the DIN rail, the clip-on locks must be turned downwards.

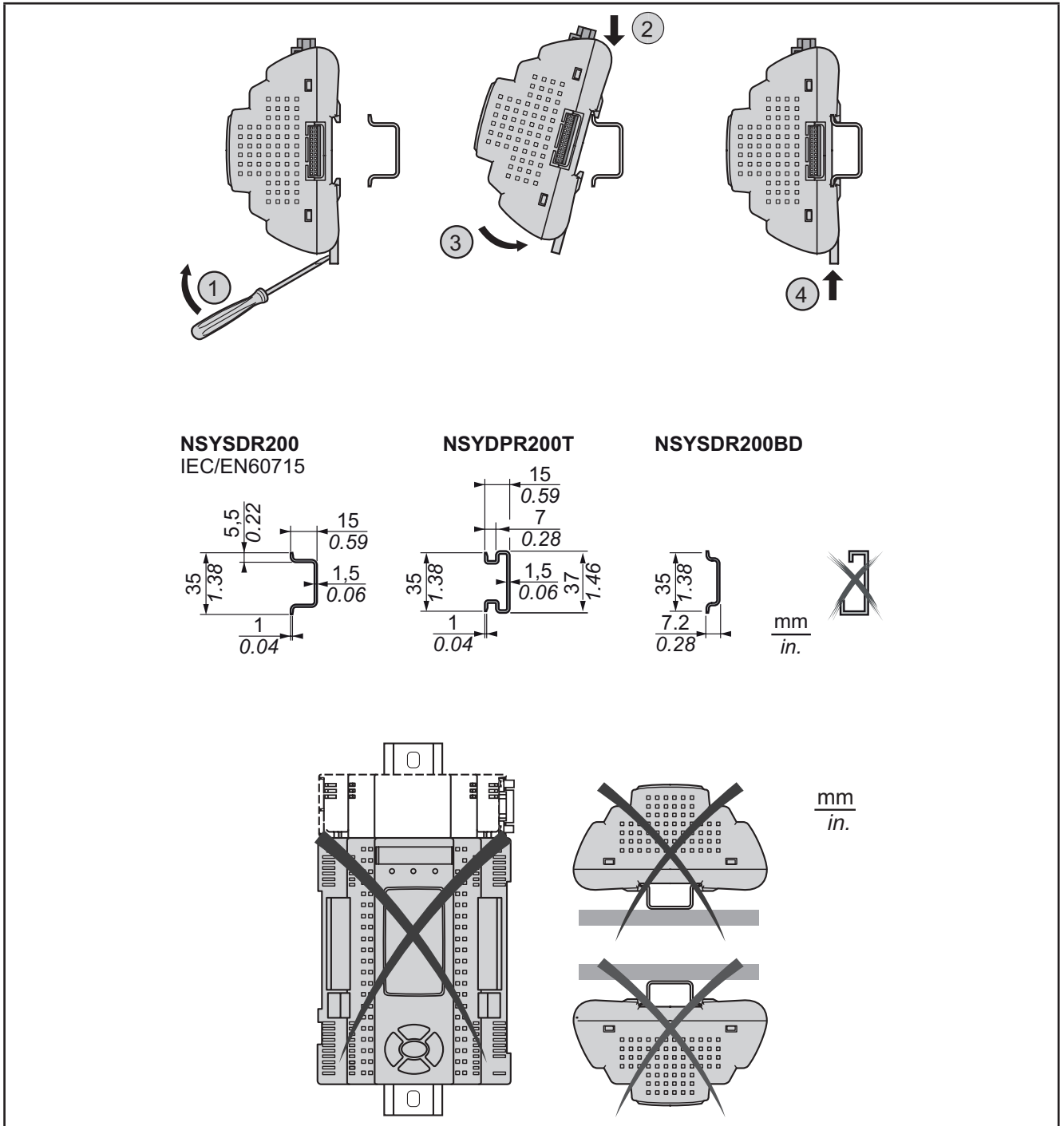

**Fig. 2.** Mounting

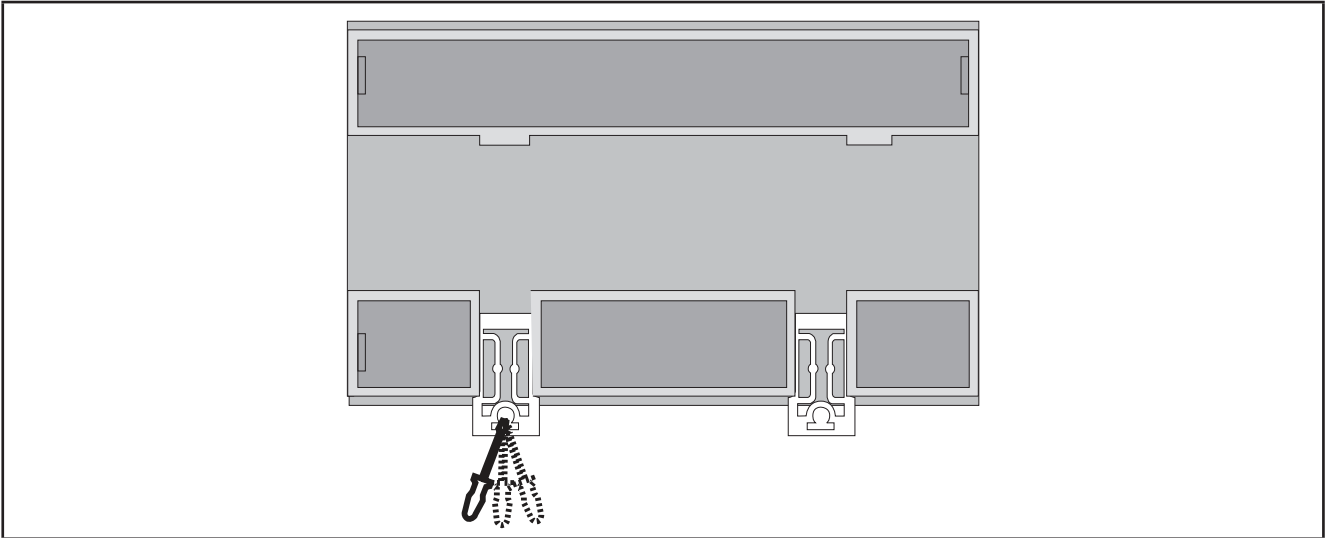

**Fig. 3.** Details of clip-on locks

The **M171 Performance logic controller** has been designed as an IP20 product and must be installed in an enclosure. Clearances must be respected when installing the product.

There are 3 types of clearances between:

- The **M171P** and all sides of the cabinet (including the panel door).
- The **M171P** terminal blocks and the wiring ducts. This distance reduces electromagnetic interference between the controller and the wiring ducts.
- The **M171P** and other heat generating devices installed in the same cabinet.

**⚠ WARNING**

**UNINTENDED EQUIPMENT OPERATION**

- Place devices dissipating the most heat at the top of the cabinet and ensure adequate ventilation.
- Avoid placing this equipment next to or above devices that might cause overheating.
- Install the equipment in a location providing the minimum clearances from all adjacent structures and equipment as directed in this document.
- Install all equipment in accordance with the specifications in the related documentation.

**Failure to follow these instructions can result in death, serious injury, or equipment damage.**

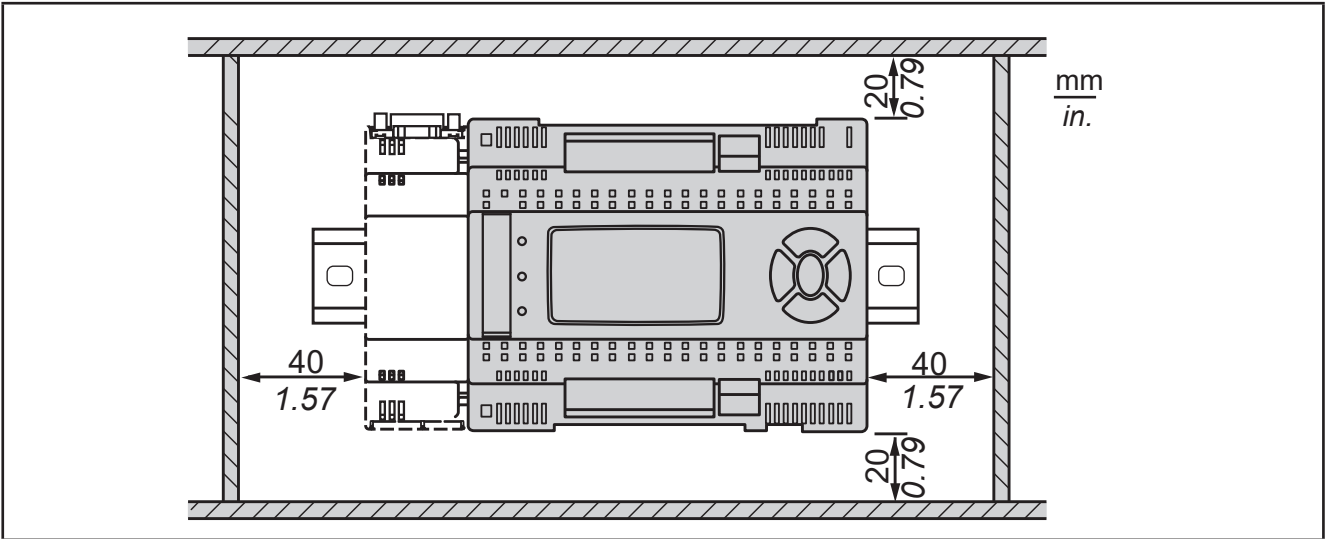

**Fig. 4.** Clearances

## 2.7. Assembling the TM171A●●●● Communication Modules

Communication Modules are 2DIN modules that connect to an **M171 Performance TM171PDM27● / TM171PBM27R** controller (refer to **Fig. 5 on page 21** and **Fig. 6 on page 21**).

To assemble **TM171A●●●●** to **TM171PDM27● / TM171PBM27R**, follow the steps described below:

1. Remove the door (if present) on the left side of the **TM171PDM27● / TM171PBM27R** controller by using fingers or a screw-driver.
2. Anchor **TM171A●●●●** to the **TM171PDM27● / TM171PBM27R** controller.
  - via the plug-in connector, behind the removable door.
  - with the fixing screws to which the Communication Module is anchored to.

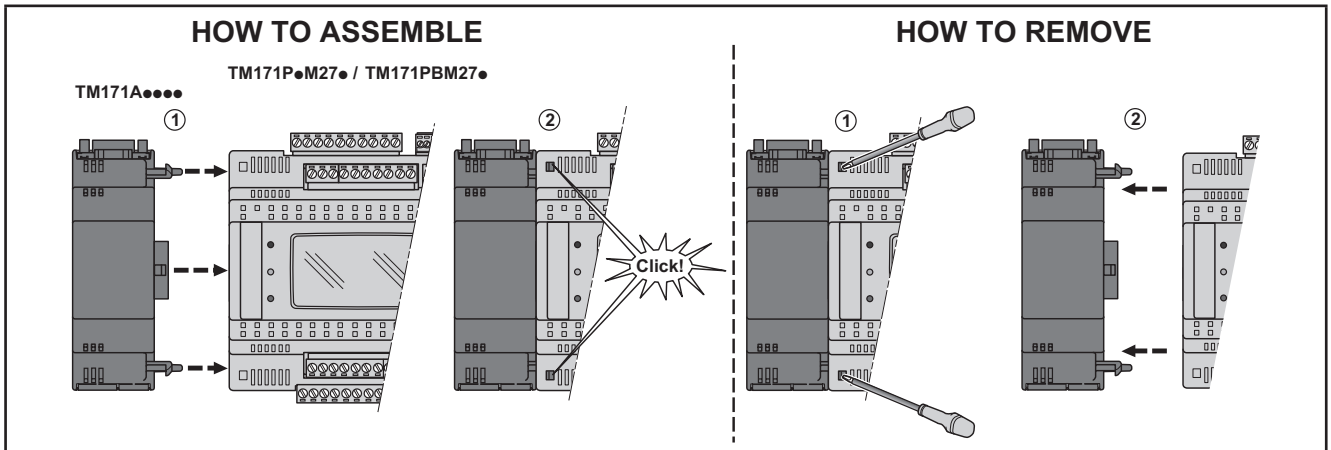

**Fig. 5.** Assembling the **TM171A●●●●** Communication Modules

Follow the instructions below to install it on DIN rail:

1. Move the clip-on locks (two for **TM171PDM27● / TM171PBM27R**, one for **TM171A●●●●**) to its standby position (use a screwdriver).
2. Install **TM171PDM27● / TM171PBM27R** + **TM171A●●●●** on the DIN rail.
3. Press the clip-on locks which will go to the closing position.
4. Once the "BASE" is mounted on the DIN rail, the clip-on locks must be turned downwards.

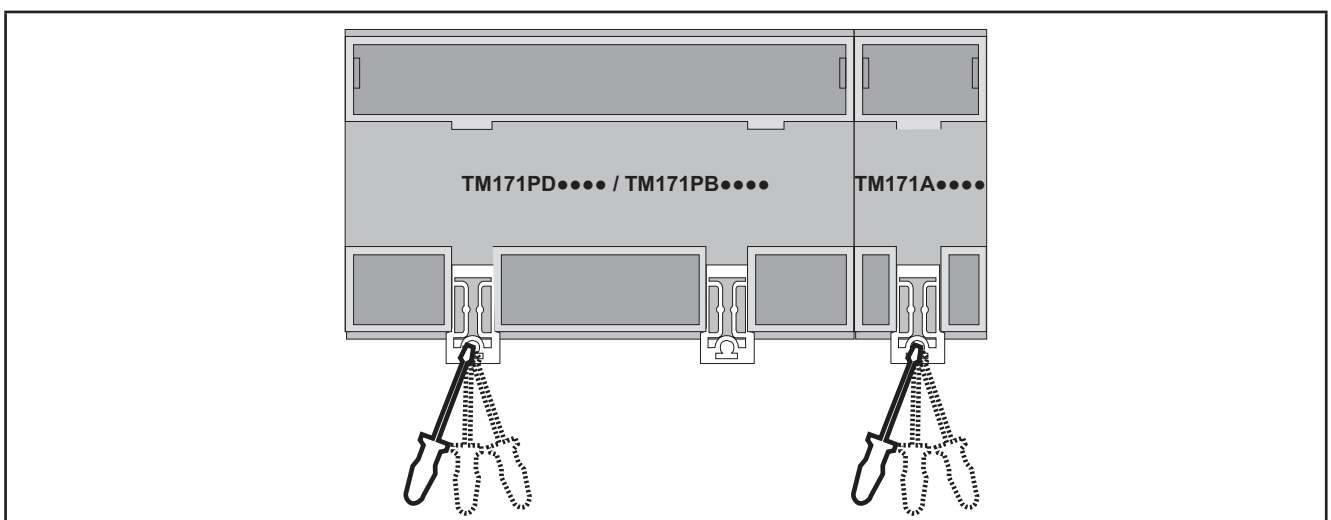

**Fig. 6.** Details of clip-on locks

## 2.8. Assembling the M171 Performance Flush or TM171DGRP

### 2.8.1. Panel mounting

The equipment is intended for panel mounting (refer to [Fig. 7 on page 22](#)).

The following figures show **M171 Performance Flush** mounting; same steps are required for **M171 Performance Display Graphic (TM171DGRP)** mounting.

For panel mounting, follow the steps described below:

1. Cut from the panel a 138 x 68 mm rectangular opening.
2. Drill, at the specified spacing, 4 holes in the panel that the controller is to be mounted on or two holes, of diameter 2.7 mm.
3. Insert the device, fixing it with the screws.
4. Press the front of the **M171 Performance Flush** to close.

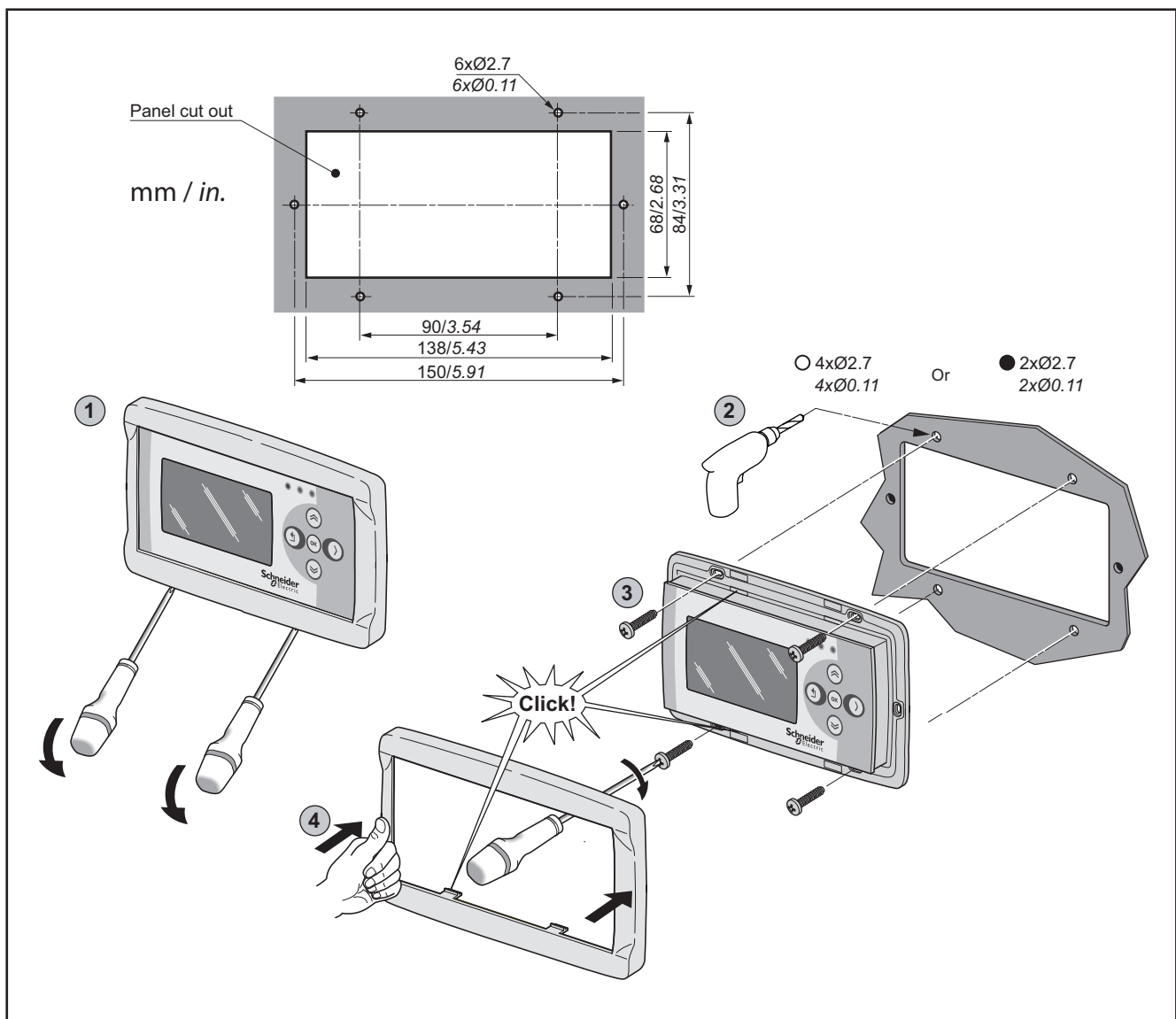
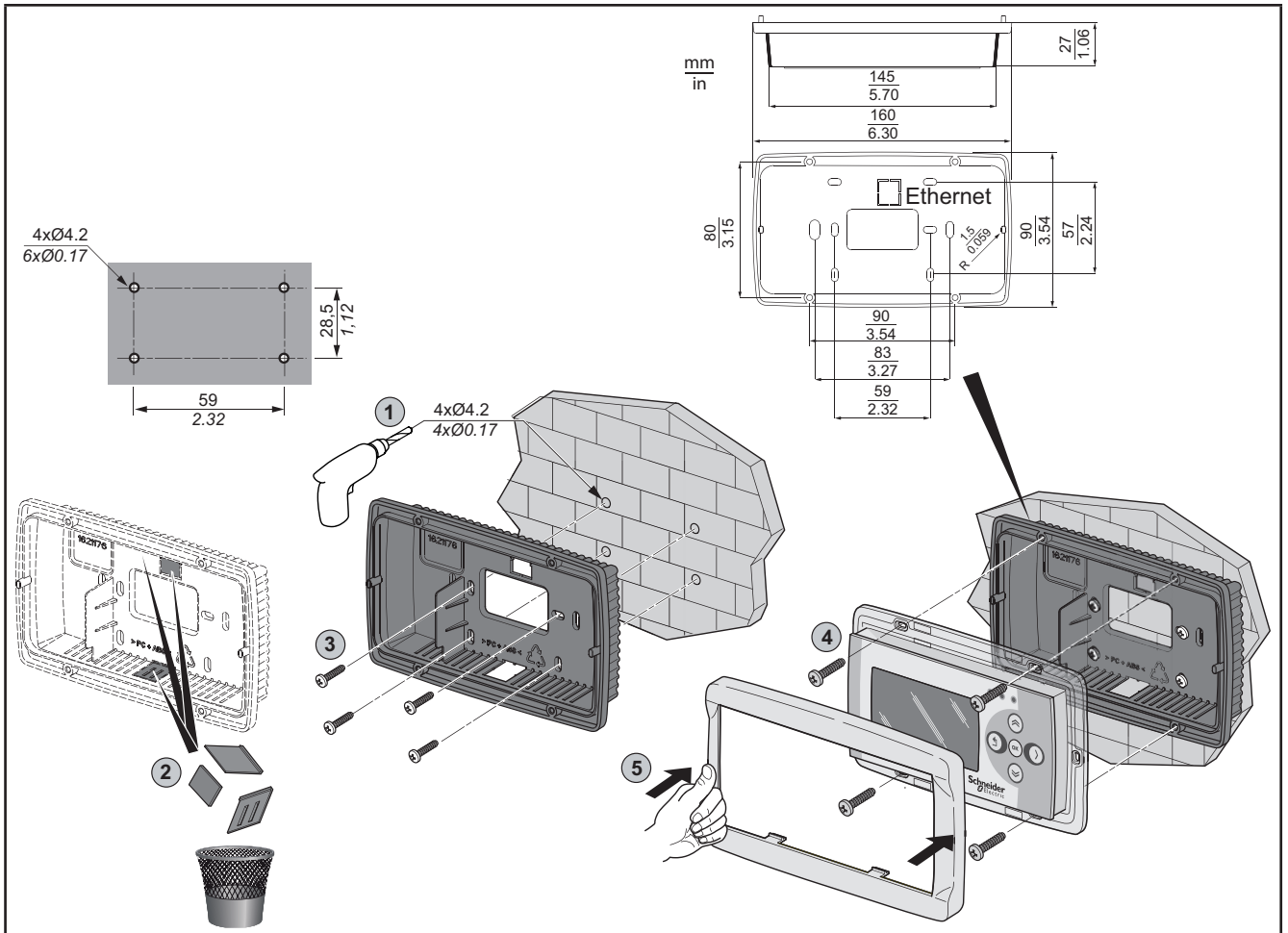

**Fig. 7.** Assembling the M171 Performance Display Graphic (TM171DGRP) or M171 Performance Flush display

## 2.8.2. Accessories for Wall mounting

The equipment is also intended for wall mounting (refer to **Fig. 8 on page 23**).  
Contact the **Schneider Electric** Sales Department for wall-mounting accessories.

1. Drill 4 holes of diameter 4.2 mm in the wall at the specified spacing to fix the backplate.
2. Use the two side slots, one at the bottom and one at the top, under the pre-formatted removable doors, preventing the opening of holes in the wall.
3. Insert the backplate, fixing it with the screws.
4. Insert the device, fixing it with the screws.
5. Press the front of the **M171 Performance Flush** to close.



**Fig. 8.** Accessories for Wall mounting

Reference	Description
TM171ABKPB	White backplate kit for wall mounting
TM171ABKPG	Black backplate kit for wall mounting

4 backplates per package.

---

## CHAPTER 3

### Electrical connections

---

#### 3.1. Wiring Best Practices

The following information describes the wiring guidelines and associated best practices to be respected when using the **M171 Performance Logic Controller**.

#### **DANGER**

##### **HAZARD OF ELECTRIC SHOCK, EXPLOSION OR ARC FLASH**

- Disconnect all power from all equipment including connected devices prior to removing any covers or doors, or installing or removing any accessories, hardware, cables, or wires.
- Always use a properly rated voltage sensing device to confirm the power is removed.
- Replace and secure all covers, accessories, hardware, cables, and wires and confirm that a proper ground connection exists before applying power to the unit.
- Use only the specified voltage when operating this equipment and any associated products.

**Failure to follow these instructions will result in death or serious injury.**

#### **WARNING**

##### **LOSS OF CONTROL**

- The designer of any control scheme must consider the potential failure modes of control paths and, for certain critical control functions, provide a means to achieve a safe state during and after a path failure. Examples of critical control functions are emergency stop and overtravel stop, power outage and restart.
- Separate or redundant control paths must be provided for critical control functions.
- System control paths may include communication links. Consideration must be given to the implications of unanticipated transmission delays or failures of the link.
- Observe all accident prevention regulations and local safety guidelines.<sup>(1)</sup>
- Each implementation of this equipment must be individually and thoroughly tested for proper operation before being placed into service.

**Failure to follow these instructions can result in death, serious injury, or equipment damage.**

<sup>(1)</sup> For additional information, refer to NEMA ICS 1.1 (latest edition), “Safety Guidelines for the Application, Installation, and Maintenance of Solid State Control” and to NEMA ICS 7.1 (latest edition), “Safety Standards for Construction and Guide for Selection, Installation and Operation of Adjustable-Speed Drive Systems” or their equivalent governing your particular location.

#### 3.1.1. Wiring Guidelines

The following rules must be applied when wiring a **M171 Performance logic controllers**:

- I/O and communication wiring must be kept separate from the power wiring. Route these two types of wiring in separate cable ducting.
- Verify that the operating conditions and environment are within the specification values.
- Use proper wire sizes to meet voltage and current requirements.
- Use copper conductors (required).
- Use twisted pair, shielded cables for analog, and/or fast I/O.
- Use twisted pair, shielded cables for networks, and fieldbus.

Use shielded, properly grounded cables for all analog and high-speed inputs or outputs and communication connections. If you do not use shielded cable for these connections, electromagnetic interference can cause signal degradation. Degraded signals can cause the controller or attached modules and equipment to perform in an unintended manner.

## ⚠ WARNING

### UNINTENDED EQUIPMENT OPERATION

- Use shielded cables for all fast I/O, analog I/O and communication signals.
- Ground cable shields for all analog I/O, fast I/O and communication signals at a single point <sup>(1)</sup>.
- Route communication and I/O cables separately from power cables.
- Make connections as short as possible and do not wind them around electrically connected parts.









**Failure to follow these instructions can result in death, serious injury, or equipment damage.**

<sup>(1)</sup> Multipoint grounding is permissible if connections are made to an equipotential ground plane dimensioned to help avoid cable shield damage in the event of power system short-circuit currents.



**NOTE:** Surface temperatures may exceed 60 °C. Route primary wiring (wires connected to power mains) separately and apart from secondary wiring (extra low voltage wiring coming from intervening power sources). If that is not possible, double insulation is required such as conduit or cable gains.

### 3.1.2. Rules for Removable Screw Terminal Block

The following table presents the cable types and wire sizes for a **5.08** or **5.00 pitch** removable screw terminal block:



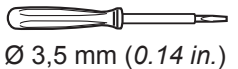





$\frac{\text{mm}}{\text{in.}}$	$\frac{7}{0.28}$								
	mm <sup>2</sup>	0.2...2.5	0.2...2.5	0.25...2.5	0.25...2.5	2 x 0.2...1	2 x 0.2...1.5	2 x 0.25...1	2 x 0.5...1.5
	AWG	24...14	24...14	22...14	22...14	2 x 24...18	2 x 24...16	2 x 22...18	2 x 20...16



 Ø 3,5 mm (0.14 in.)		$\text{N}\cdot\text{m}$	0.5...0.6
		$\text{lb}\cdot\text{in}$	4.42...5.31

**Fig. 9.** Pitch 5.08 mm (0.20 in.) or 5.00 mm (0.197 in.)

The following table presents the cable types and wire sizes for a **3.81** or **3.50 pitch** removable screw terminal block:

$\frac{\text{mm}}{\text{in.}}$	$\frac{7}{0.28}$								
	mm <sup>2</sup>	0.2...2.5	0.2...2.5	0.25...2.5	0.25...2.5	2 x 0.2...1	2 x 0.2...1.5	2 x 0.25...1	2 x 0.5...1.5
	AWG	24...14	24...14	22...14	22...14	2 x 24...18	2 x 24...16	2 x 22...18	2 x 20...16

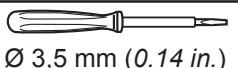
 Ø 3,5 mm (0.14 in.)		$\text{N}\cdot\text{m}$	0.5...0.6
		$\text{lb}\cdot\text{in}$	4.42...5.31

**Fig. 10.** Pitch 3.81 mm (0.15 in.) or 3.50 mm (0.14 in.)

---

**⚠ ⚠ DANGER**

**LOOSE WIRING CAUSES ELECTRIC SHOCK**

Tighten connections in conformance with the torque specifications.

**Failure to follow these instructions will result in death or serious injury.**

**⚠ DANGER**

**FIRE HAZARD**

- Use only the correct wire sizes for the current capacity of the I/O channels and power supplies.
- For 2 A - relay output wiring, use conductors with a cross section at least equal to 0.5 mm<sup>2</sup> (AWG 20) and a temperature rating at least equal to 80 °C (176 °F).
- For 3 A - relay output wiring, use conductors with a cross section at least equal to 1.5 mm<sup>2</sup> (AWG 16) and a temperature rating at least equal to 80 °C (176 °F).
- For common conductors of 8 A - relay output wiring, or greater than 3 A - relay output wiring, use conductors with a cross section at least equal to 2.0 mm<sup>2</sup> (AWG 12) and a temperature rating at least equal to 80 °C (176 °F).

**Failure to follow these instructions will result in death or serious injury.**

**3.1.3. Protecting Outputs from Inductive Load Damage**

If your controller or module contains relay outputs, these types of outputs can support up to 250 Vac (240 Vac if SSR). Inductive damage to these types of outputs can result in welded contacts and loss of control. Each inductive load must include a protection device such as a peak limiter, RC circuit or flyback diode. Capacitive loads are not supported by these relays.

**⚠ WARNING**

**RELAY OUTPUTS WELDED CLOSED**

- Always protect relay outputs from inductive alternating current load damage using an appropriate external protective circuit or device.
- Do not connect relay outputs to capacitive loads.

**Failure to follow these instructions can result in death, serious injury, or equipment damage.**

Depending on the load, a protection circuit may be needed for the outputs on the controllers and certain modules. Inductive loads using DC voltages may create voltage reflections resulting in overshoot that will damage or shorten the life of output devices.

**⚠ CAUTION**

**OUTPUT CIRCUIT DAMAGE DUE TO INDUCTIVE LOADS**

Use an appropriate external protective circuit or device to reduce the risk of inductive direct current load damage

**Failure to follow these instructions can result in injury or equipment damage.**

Choose a protection circuit from the following diagrams according to the power supply used. Connect the protection circuit to the outside of the controller or relay output module.

**Protective circuit A:** this protection circuit can be used for both AC and DC load power circuits.

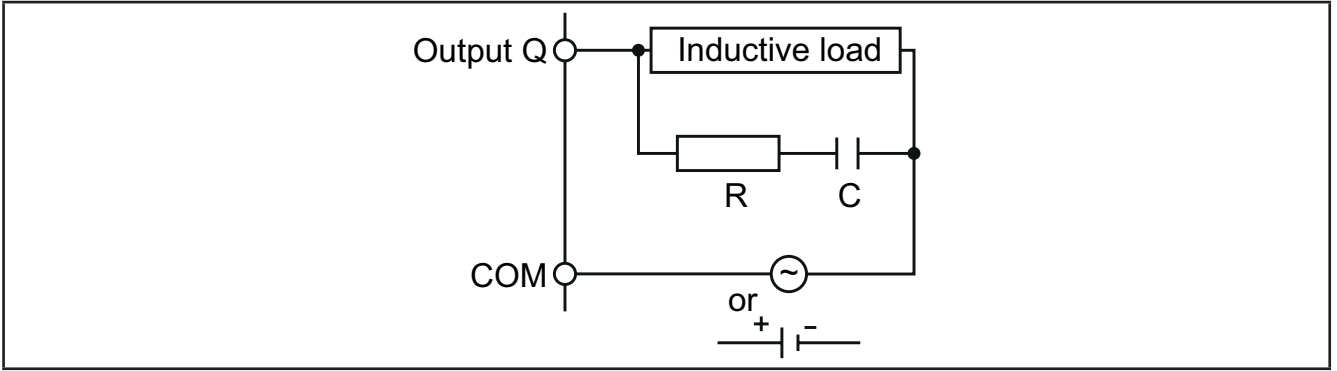

Fig. 11. Protective circuit A

**C** Value from 0.1 to 1  $\mu\text{F}$

**R** Resistor of approximately the same resistance value as the load

**Protective circuit B:** this protection circuit can be used for DC load power circuits.

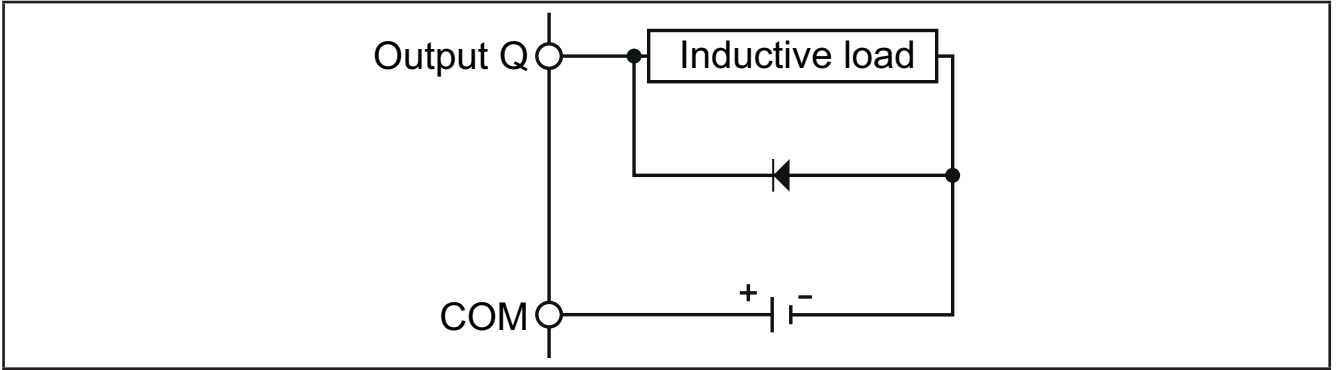

Fig. 12. Protective circuit B

Use a diode with the following ratings:

- Reverse withstand voltage: power voltage of the load circuit x 10.
- Forward current: more than the load current.

**Protective circuit C:** this protection circuit can be used for both AC and DC load power circuits.

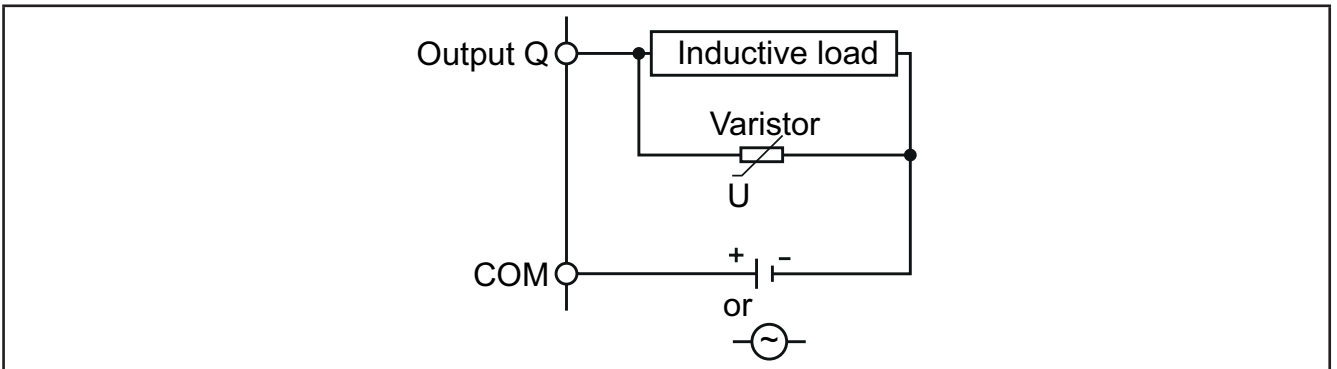

Fig. 13. Protective circuit C

In applications where the inductive load is switched on and off frequently and/or rapidly, ensure that the continuous energy rating (J) of the varistor exceeds the peak load energy by 20 % or more.

**NOTE:** Place protection devices as close to the load as possible.

### 3.1.4. Special handling considerations

Care must be taken to avoid damage from electrostatic sources when handling this equipment. In particular exposed connectors and, in some cases, exposed printed circuit boards are vulnerable to electrostatic discharge.

<b>⚠ WARNING</b>
<p><b>UNINTENDED EQUIPMENT OPERATION DUE TO ELECTROSTATIC DISCHARGE DAMAGE</b></p> <ul style="list-style-type: none"> <li>• Keep equipment in the protective conductive packaging until you are ready to install the equipment.</li> <li>• Only install equipment in approved enclosures and / or locations that prevent unauthorized access and provide electrostatic discharge protection.</li> <li>• Use a conductive wrist strap or equivalent field force protective device attached to an earth ground when handling sensitive equipment.</li> <li>• Always discharge yourself by touching a grounded surface or approved antistatic mat before handling the equipment.</li> </ul> <p><b>Failure to follow these instructions can result in death, serious injury, or equipment damage.</b></p>

### 3.1.5. Analog Inputs-Probes

Temperature probes have no connection polarity and can be extended using a normal bipolar cable.

<b>⚠ WARNING</b>
<p><b>UNINTENDED EQUIPMENT OPERATION DUE TO CONNECTION</b></p> <ul style="list-style-type: none"> <li>• Apply power to all externally powered devices after applying power to the M171 Performance logic controllers.</li> <li>• Signal leads (probes, digital inputs, communication and the electronic supply) must be routed separately from power cables.</li> </ul> <p><b>Failure to follow these instructions can result in death, serious injury, or equipment damage.</b></p>

<b>NOTICE</b>
<p><b>INOPERABLE EQUIPMENT</b></p> <p>Verify all wiring connections before applying power.</p> <p><b>Failure to follow these instructions can result in equipment damage.</b></p>

**NOTE:** The extension of the probes influences the electromagnetic compatibility (EMC) of the equipment.

**NOTE:** Connection polarity must be correctly respected for probes which need a specific polarity.

### 3.1.6. Serial connections

	The reference has on-board serial
<b>M171 Performance</b>	CAN, RS485, USB
<b>M171 Performance Flush</b>	CAN, RS485, ETHERNET

Pay special attention when connecting serial lines. Miswiring may lead to inoperable equipment.

<b>NOTICE</b>
<p><b>INOPERABLE EQUIPMENT</b></p> <ul style="list-style-type: none"> <li>• Do not connect equipment that communicate using RS485 serial to CAN terminals.</li> <li>• Do not connect CAN equipment to RS485 terminals.</li> </ul> <p><b>Failure to follow these instructions can result in equipment damage.</b></p>

Communication Modules **TM171A●●●●** provide additional serial ports for integration with industrial systems, BMS and Ethernet.

Controller serials are defined as “on-board” (OB) whereas serials on **TM171A●●●●** are referred to as Communication Modules (PI, stands for "Plug In").

## CAN Expansion Bus

- Use a shielded and "**twisted pair**" cable with two 0.5 mm<sup>2</sup> section conductors (AWG 22), plus braid such as Belden cable reference 3105A (characteristic impedance 120 Ω) with PVC sleeve, nominal capacity between conductors 36 pF/m, nominal capacity between conductor and shielding 68 pF/m.
- Always follow regulations applicable to the routing and connection of cables. Make certain that data transmission circuits are properly separated from power lines.
- For connections over longer distances, it is better to end the line with resistors on both ends, inserting the two **R TERM** jumpers (available on the terminal strip next to the CAN Expansion Bus as the default configuration).
- The maximum distance depends on the baud setting (see the following table).

kb/s (kbaud)	On-board CAN (m) - M171 Performance	CAN Communication Module (m)
50	1000	1000
125	500	500
250	200	250
500	30	60

- CAN Expansion Bus is used to communicate with **M171 Performance Display Graphic (TM171DGRP)** terminal and **M171 Performance Expansion** terminal.

## RS 485

- Use a shielded and "**twisted pair**" cable with two 0.5 mm<sup>2</sup> section conductors (AWG 22), plus braid such as Belden cable reference 3105A (characteristic impedance 120 Ω) with PVC sleeve, nominal capacity between conductors 36 pF/m, nominal capacity between conductor and shielding 68 pF/m. Alternatively use a shielded and "**twisted pair**" cable with two 0.5 mm<sup>2</sup> section conductors (AWG 20), plus braid such as Belden cable reference 8762 with PVC sleeve, nominal capacity between conductors 89 pF/m, nominal capacity between conductor and shielding 161 pF/m. See EN 50174 standard on IT cabling for indications on how cables should be routed.
- Always follow regulations applicable to the routing and connection of cables. Make certain that data transmission circuits are properly separated from power lines.
- RS 485 network up to 1200 m in length with a maximum of 32<sup>(1)</sup> devices can be connected directly to the controller.
  - <sup>(1)</sup> Example of **M171 Performance** Modbus Slave with single Master supervisor.  
This length can be extended and the number of devices for each channel increased using appropriate repeater modules.
- Single terminal strip with 3 conductors: use all 3 conductors ("+", "-", "GND" for the braid).
- Attach the 120 Ω 1/4 W resistors between the "+" and "-" terminals of the interface and the last controller in each branch of the network.
- Maximum settable speed 115200 baud.
- RS 485 physical layer can be used for Modbus SL, as well as for BACnet MS/TP communication. Concurrent communication of different protocols on the same serial port is **NOT** allowed.

Pay special attention when connecting serial lines. Miswiring may lead to inoperable equipment.

### **NOTICE**

#### **INOPERABLE EQUIPMENT**

Do not communicate through Modbus SL and BACnet MS/TP simultaneously on the same line.

**Failure to follow these instructions can result in equipment damage.**

## Ethernet

The Ethernet connection of the Communication Module **TM171AETH / TM171AETHRS485** allows the **M171 Performance** logic controller to communicate on an Ethernet network using TCP/IP protocol, whereas **M171 Performance Flush**, with its embedded Ethernet, does **NOT** require an Ethernet Communication Module.

The connection allows:

- connection of different controllers and/or applications exchanging variables and/or parameters (network).
- connection of a supervision system using Modbus TCP/IP protocol.
- connection of an IEC 61131-3 **EcoStruxure Machine Expert HVAC** development system.
- connection on device on a BACnet/TCP network, with B-AAC profile

Concurrent communication on different protocols using the same Ethernet port is allowed.

The Ethernet connector shield is internally connected to the earth of the equipment and therefore to the reference of the input and output channels.

## USB

There are 2 USB connectors placed on the upper-left side of the **M171 Performance** controller (in the front view) (see **Fig. 14 on page 30**).

- USB Type A is a connector for USB memory key.
- USB Type mini-B is used for programming purposes.  
The components required for **M171 Performance** USB mini-B are: **TCSXCNAMUM3P** or **BMXXCAUSBH018**.

USB	PURPOSE	NOTE
Type A (HOST)	Used to connect a USB memory key when downloading the application. This should be done from the controller keypad ( <b>TM171PDM27●</b> references) or from the <b>M171 Performance Display Graphic</b> ( <b>TM171DGRP</b> ) ( <b>TM171PBM27R</b> reference).	-
Type mini-B (DEVICE)	Used to connect <b>M171 Performance</b> to a PC via mini-B USB cable for debugging, commissioning, downloading, uploading with <b>EcoStruxure Machine Expert HVAC</b> . The operations can be done from PC or another device.	Compatible with the following operating systems: <ul style="list-style-type: none"> <li>• Windows 8 / 8.1, 64-Bit</li> <li>• Windows 10, 64-Bit</li> </ul> The driver is supplied with the <b>EcoStruxure Machine Expert HVAC</b> software.

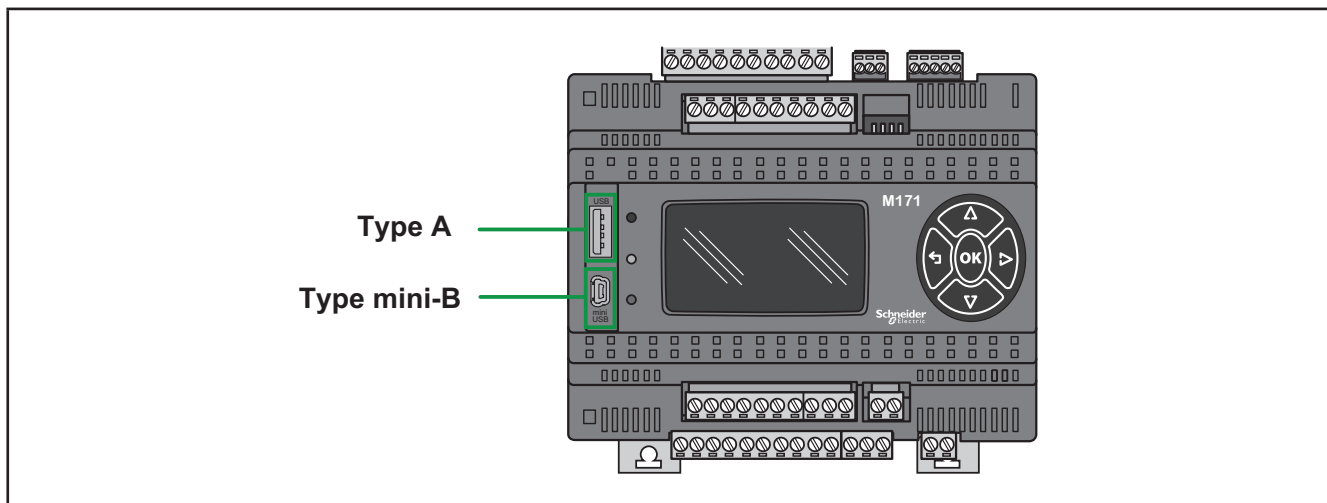

**Fig. 14.** M171 Performance: type A USB and type mini-B USB

## 3.2. Wiring diagrams

Miswiring irreversibly damages the **Modicon M171P**.

### NOTICE

#### INOPERABLE EQUIPMENT

Verify all wiring connections before applying power.

**Failure to follow these instructions can result in equipment damage.**

### 3.2.1. Modicon M171P wiring diagram

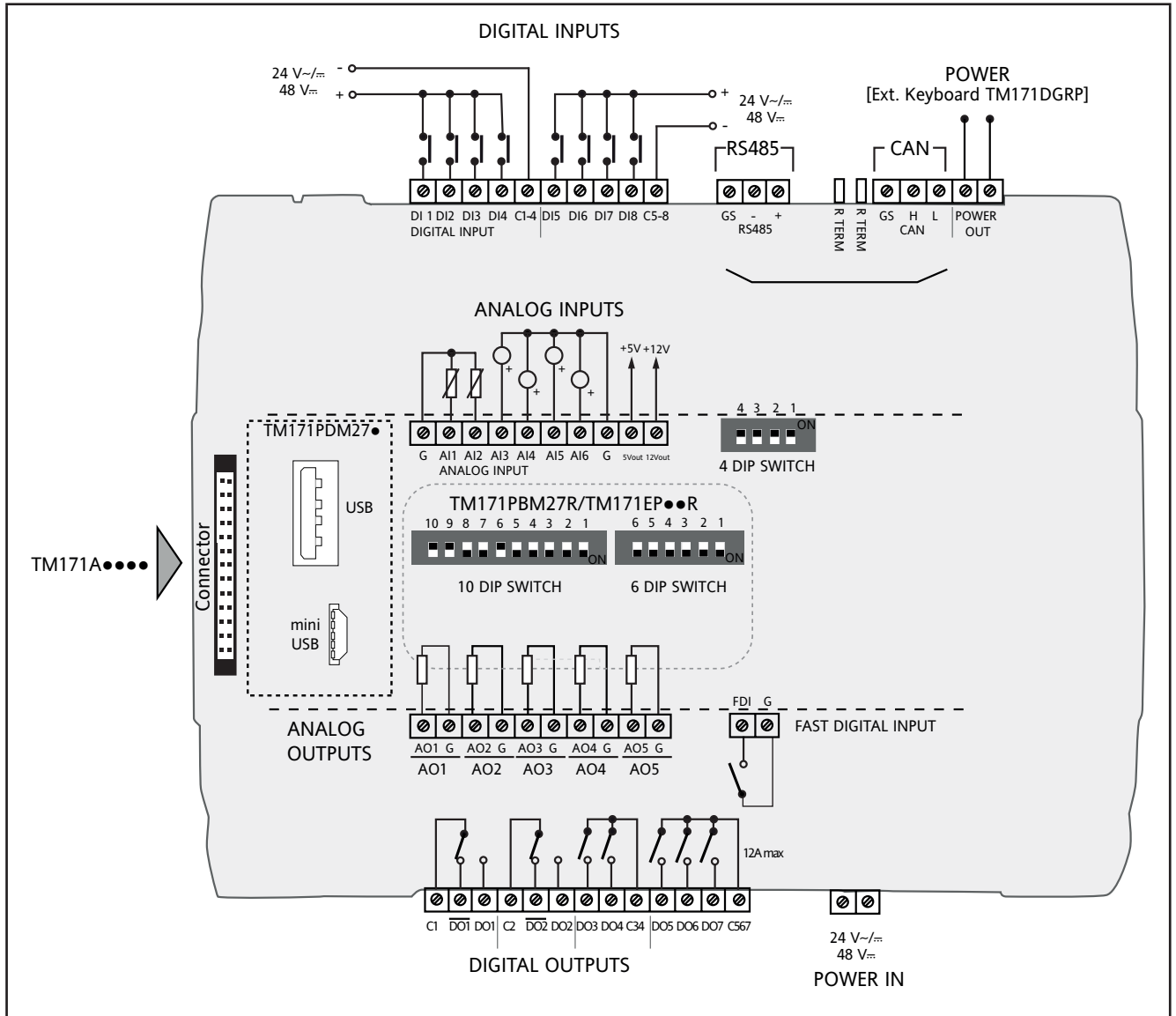

Fig. 15. Modicon M171P wiring diagram

## Connector Labels Related To M171 Performance

	LABEL	DESCRIPTION	NOTES
DIP SWITCH	4 DIP SWITCH	4-position selectors (Dip Switches)	Dip Switches default OFF
	6 DIP SWITCH	6-position selectors (Dip Switches)	Dip Switches default OFF
	10 DIP SWITCH	10-position selectors (Dip Switches)	<b>TM171PBM27R /TM171EP27R</b> reference Dip Switches located behind the panel
POWER SUPPLY	POWER IN	+24 Vac/dc or +48 Vdc power supply	-
	POWER OUT	+24 Vac/dc or +48 Vdc power supply	<b>POWER [Ext. Keyboard M171 Performance Display Graphic (TM171DGRP)]</b> output for display
ANALOG OUTPUTS	AO1...AO5	Analog outputs 1...5	See <b>CHAPTER 4 Technical data on page 65</b> for further details
	G	0 V signal ground	
DIGITAL OUTPUTS	C1 DO1 $\overline{\text{DO1}}$	SPDT Relay 1	DO1 is the normally open side, $\overline{\text{DO1}}$ is the normally closed side
	C2 DO2 $\overline{\text{DO2}}$	SPDT Relay 2	DO2 is the normally open side, $\overline{\text{DO2}}$ is the normally closed side
	DO3 DO4	Relay output 3-4 also available as SSR outputs	-
	C34	Common for digital outputs 3-4	
	DO5 DO6 DO7	Relay output 5-6-7	
	C567	Common for digital outputs 5-6-7	12 A max
CAN	GS H L	Isolated CAN serial <b>GS</b> ground serial isolated from <b>G</b>	<b>R TERM</b> termination resistors for CAN
RS485	GS - +	Isolated RS485 serial <b>GS</b> ground serial isolated from <b>G</b>	Apply 120 $\Omega$ termination resistors
DIGITAL INPUTS	DI1...DI4	Digital inputs 1...4	-
	C1-4	Common for digital inputs 1...4	
	DI5...DI8	Digital inputs 5...8	
	C5-8	Common for digital inputs 5...8	
FAST D.I.	FDI	Fast digital input	Pulse/frequency counter up to 1 kHz
	G	0 V signal ground	
ANALOG INPUTS	AI1...AI6	Analog inputs	-
	G	0 V signal ground	
SENSOR POWER SUPPLY	12Vout	12V output for analog inputs	-
	5Vout	5V output for ratiometric analog inputs	

### 3.2.2. Modicon M171EP14R wiring diagram

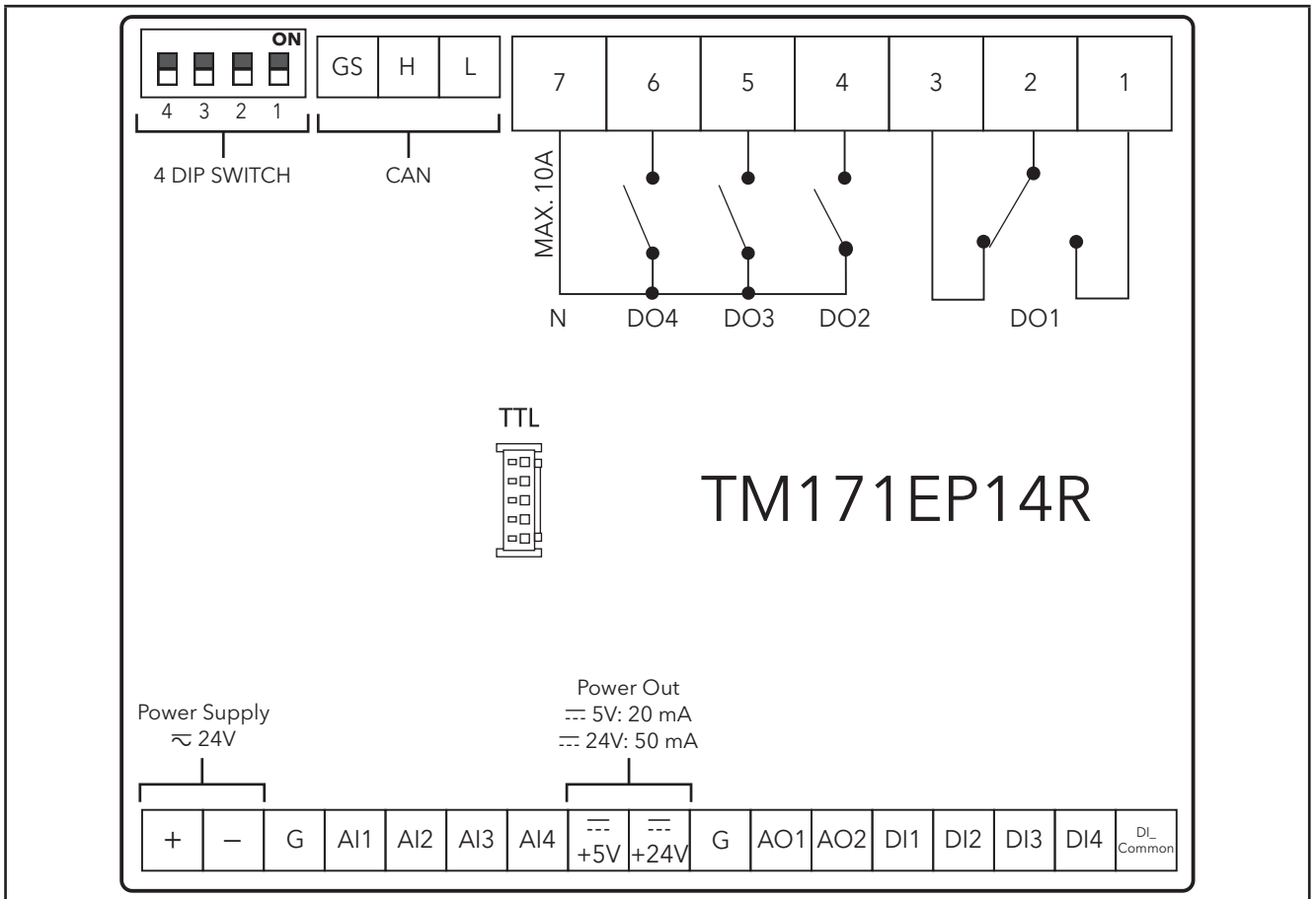

Fig. 16. Modicon M171EP14R wiring diagram

### Connector Labels Related To M171EP14R

	LABEL	DESCRIPTION	NOTES
DIP SWITCH	4 DIP SWITCH	4-position selectors (Dip Switches)	Dip Switches default OFF
POWER SUPPLY	+ / -	+24 Vac/dc power supply	-
ANALOG OUTPUTS	AO1, AO2	Analog outputs 1 and 2	See <a href="#">CHAPTER 4 Technical data on page 65</a> for further details
	G	0 V signal ground	
	+24V	Power Out +24 Vdc output	
	+5V	Power Out +5 Vdc output	
DIGITAL OUTPUTS	1-2-3	SPDT Relay output <b>DO1</b>	<b>1</b> is the normally open side, <b>3</b> is the normally closed side
	4-5-6	SPST Relay output 2-3-4 <b>DO2 DO3 DO4</b>	-
	7	Common for relay outputs 2-3-4 <b>N</b>	10 A max
CAN	GS H L	Isolated CAN serial <b>GS</b> ground serial isolated from <b>G</b>	Dip Switches <b>3-4</b> termination resistors for CAN
DIGITAL INPUTS	DI1...DI4	Digital inputs 1...4	-
	DI_Common	Common for digital inputs 1...4	-
ANALOG INPUTS	AI1...AI4	Analog inputs	-
	G	0 V signal ground	-

### 3.2.3. Examples of analog input connection (M171 Performance only)

#### Example: NTC/Pt1000 probe connection

- Analog inputs AI1...AI6 are available for NTC
- Analog inputs AI3...AI6 are available for NTC/Pt1000

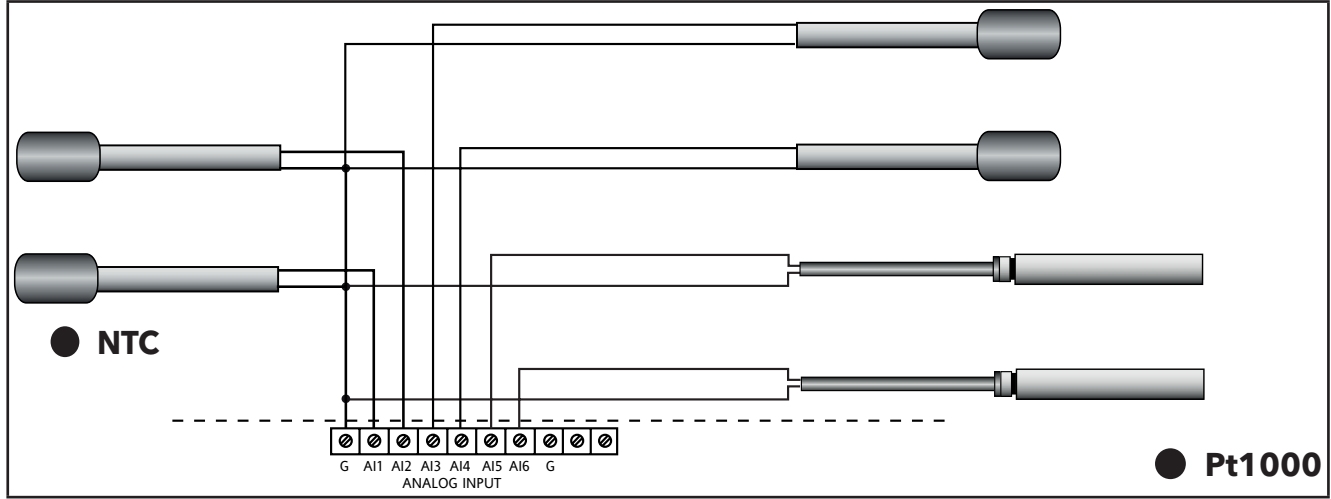

Fig. 17. NTC/Pt1000 probe connection

#### Example: 0-10 V transducer connection

Analog Inputs AI3...AI6 are available for 0-10 V transducer connection

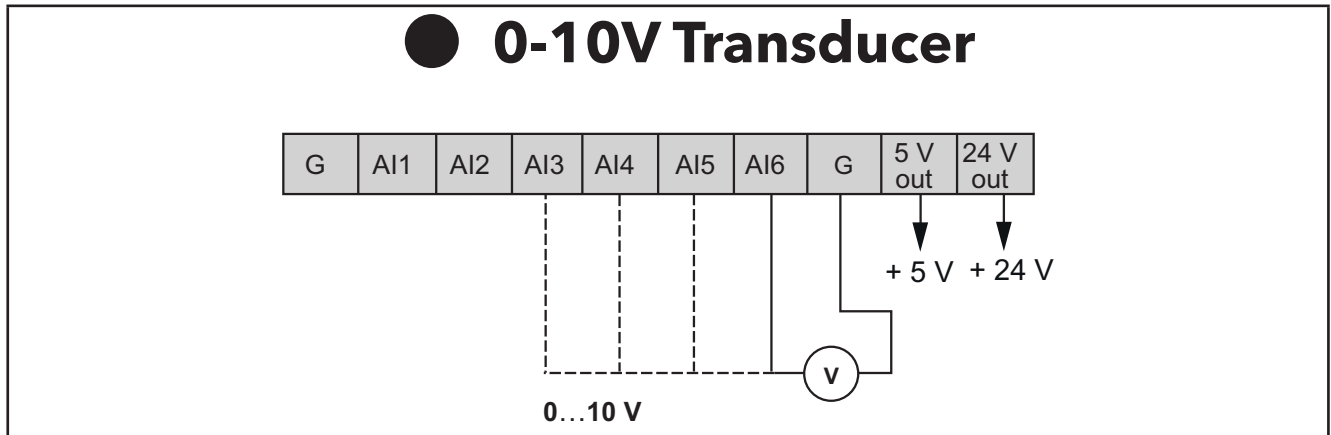

Fig. 18. 0-10 V transducer connection

#### Example: Digital Input Connection (through analog input terminal)

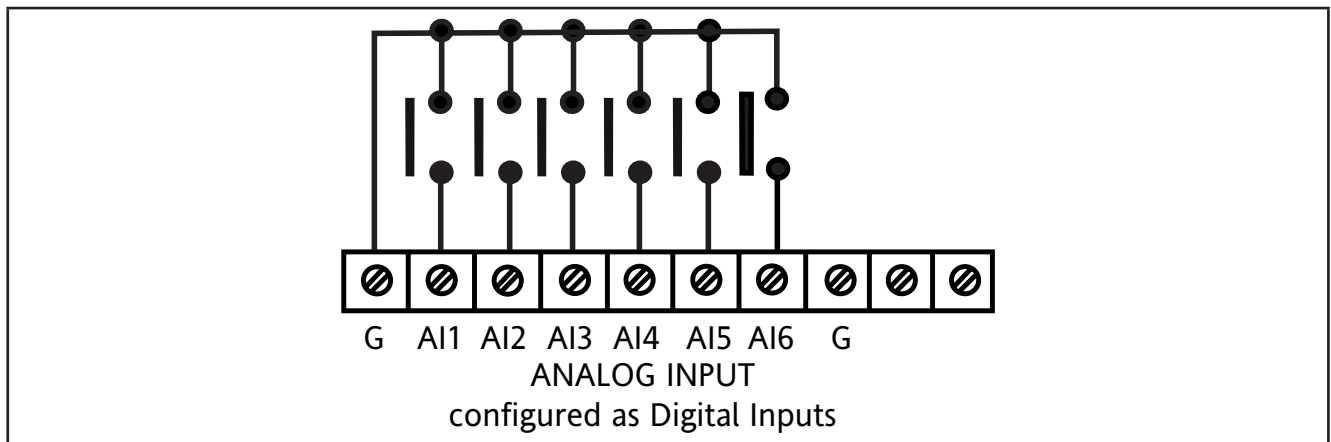

Fig. 19. Analog Inputs configured as Digital Inputs

## Example: 4...20 mA pressure transducer connection

Analog Inputs AI3...AI6 are available as 4...20 mA pressure transducer connection.

In the case of a generic 3-wire transducer, connect the 0 V reference wire (ground if so indicated by the transducer manufacturer) to terminal GND and the transducer power supply to **12 Vdc** screw terminal.

### NOTICE

#### INOPERABLE EQUIPMENT

Verify all wiring connections before applying power.

**Failure to follow these instructions can result in equipment damage.**

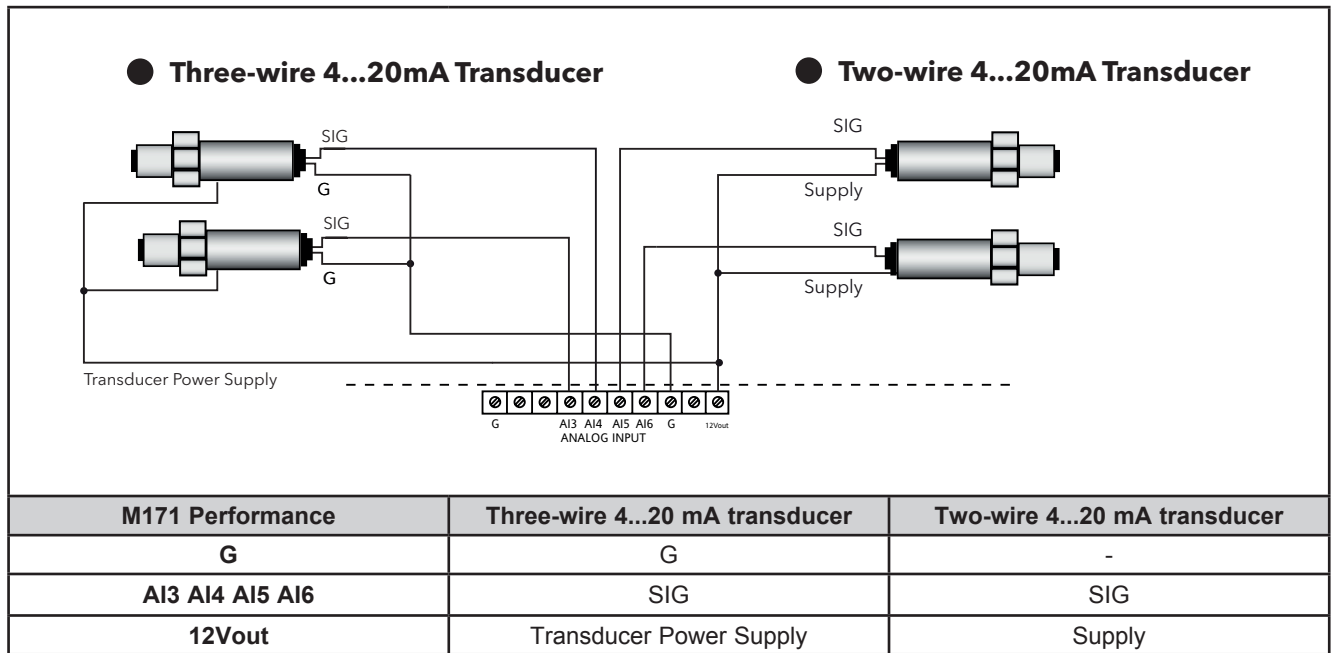

Fig. 20. 4...20 mA pressure transducer connection

### Example: ratiometric transducer connection

Analog Inputs AI3...AI6 are available as ratiometric transducer connection

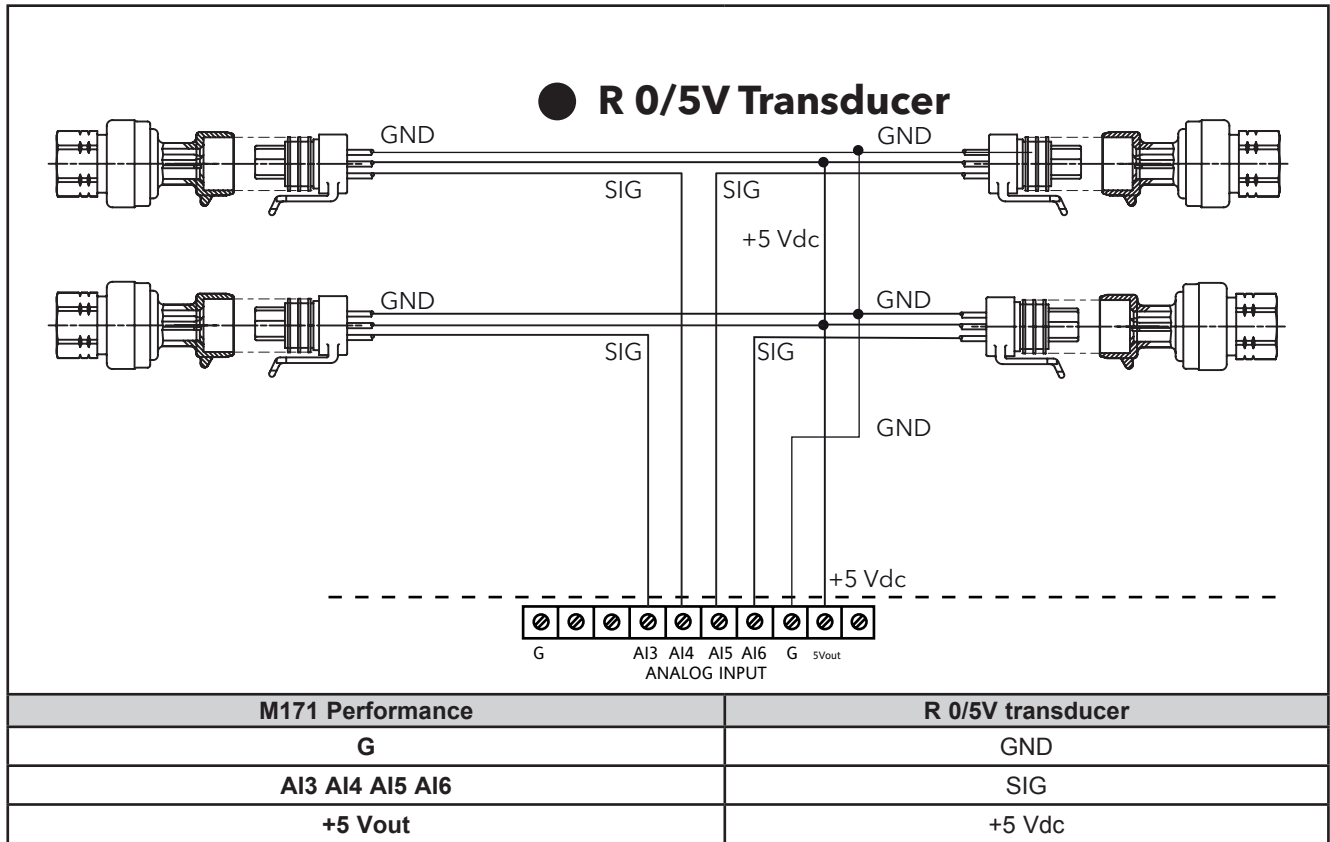

Fig. 21. Ratiometric transducer connection

### Example: fan module connection

- 5 available analog outputs: AO1...AO5
- Example diagram with 4 ...20mA or 0-10V fan module

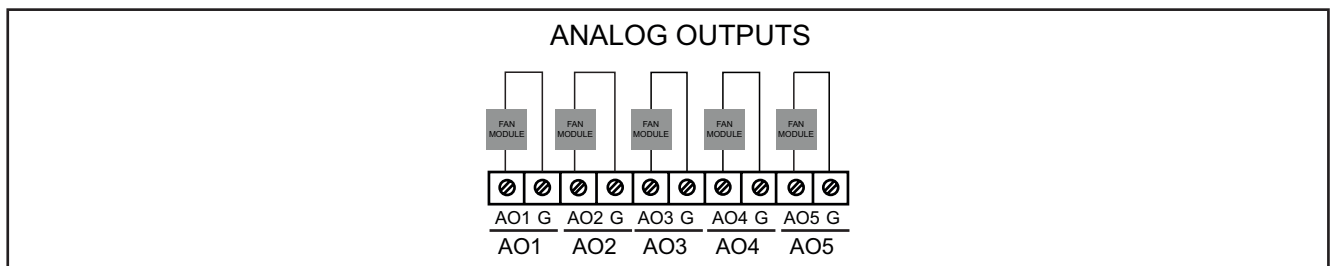

Fig. 22. Fan module connection

### Example: Open Collector connection

- 2 Open Collector outputs available as Open Collector connection: AO4/AO5
- Example with an external relay

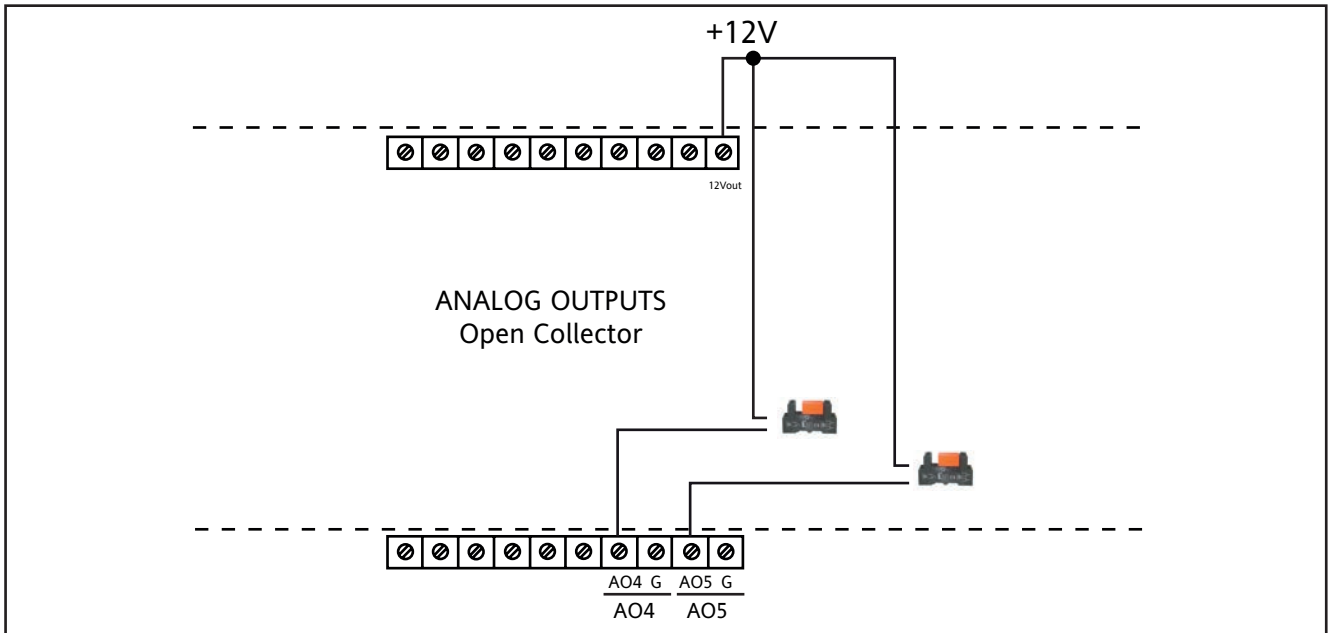

Fig. 23. Open Collector connection

### 3.2.4. M171 Performance / M171 Display Graphic connection

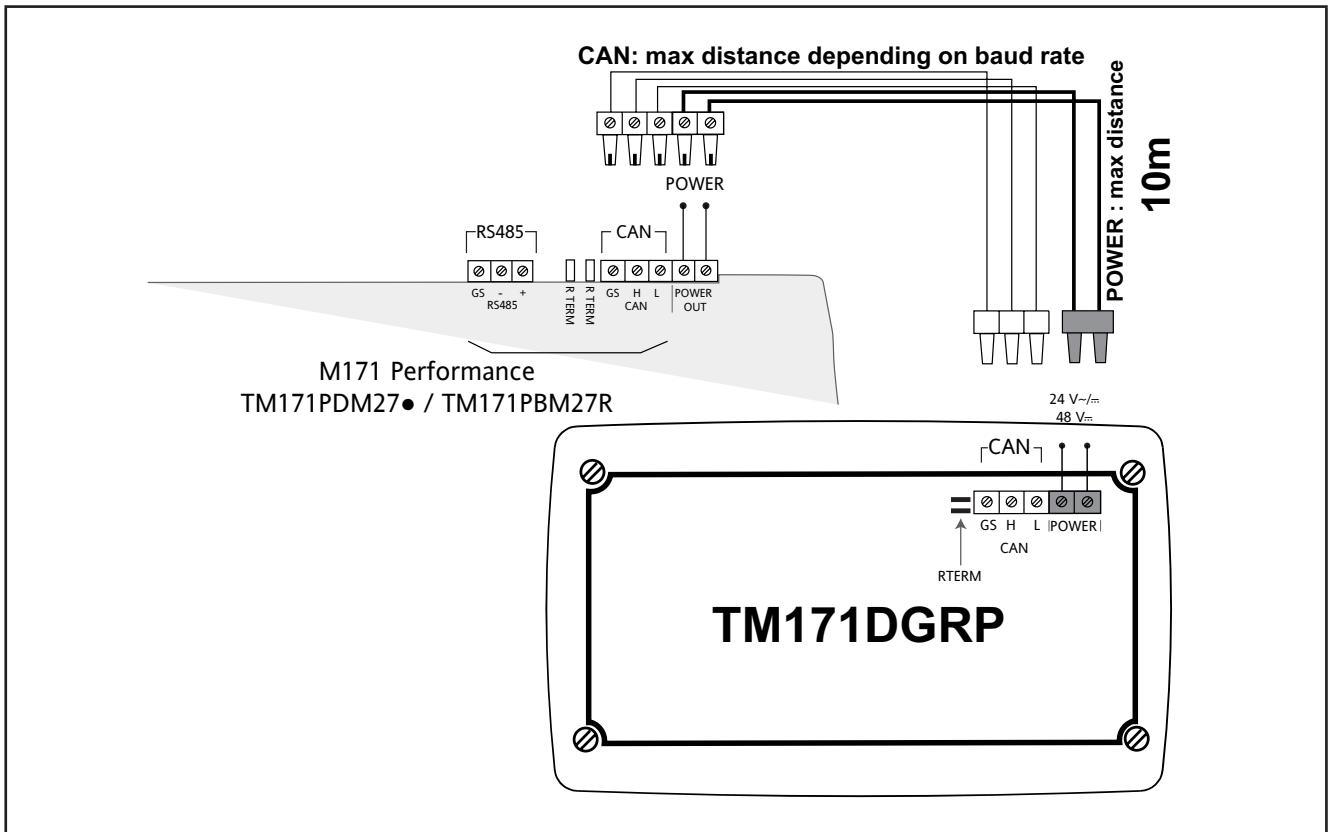

Fig. 24. M171 Performance / M171 Performance Display Graphic (TM171DGRP) terminal connection

**NOTE:** When supplying power from the **M171 Performance logic controllers**, make the power connection cable as short as possible.

## NOTICE

### INOPERABLE EQUIPMENT

Do not connect a power cable longer than 10m.

**Failure to follow these instructions can result in equipment damage.**

	LABEL	DESCRIPTION	NOTES
POWER	POWER IN	+24 Vac/dc or +48 Vdc power supply	Maximum cable length 10m
			from <b>TM171P•M27•</b> or separate power supply
CAN	GS H L	Isolated CAN serial <b>GS</b> ground serial insulated from <b>G</b>	R TERM termination resistors for CAN
			Maximum cable length See <a href="#">3.1.6. Serial connections on page 28</a>

### 3.2.5. M171 Performance Flush TM171PFE03 and TM171PFE03HR connection

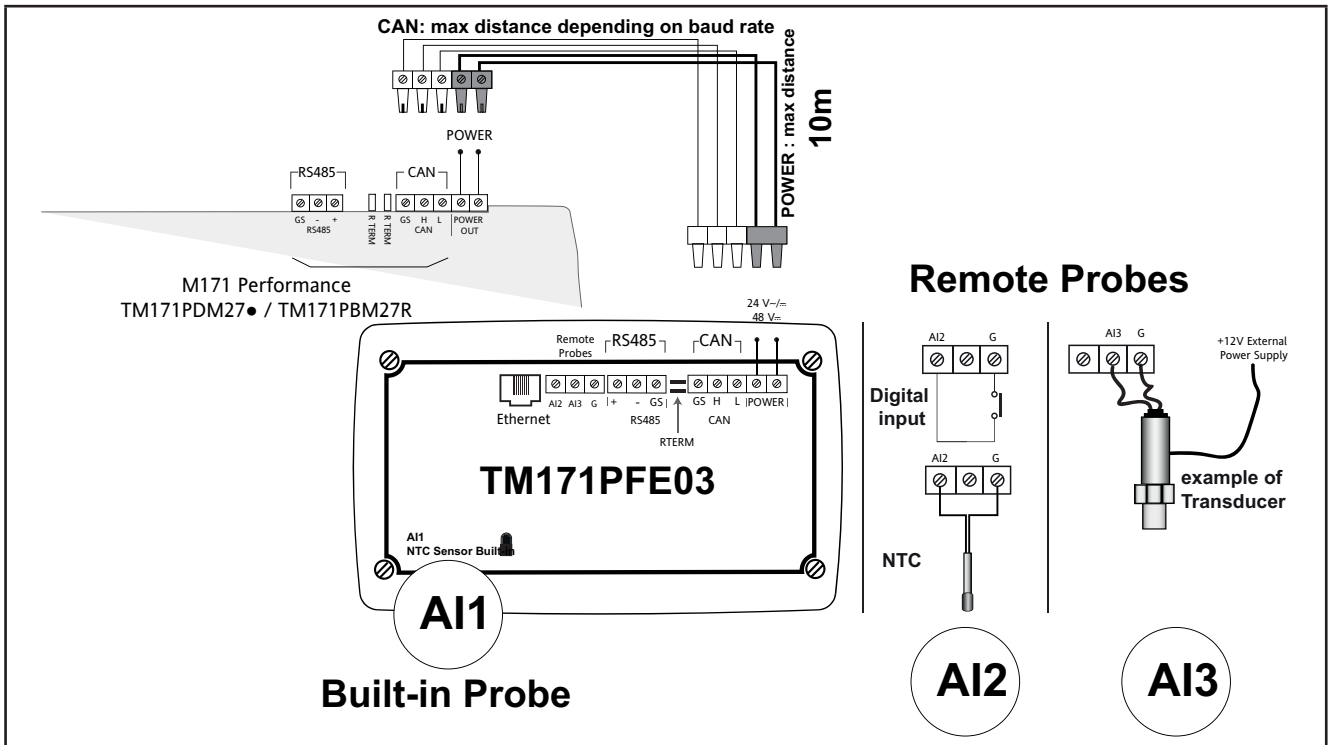

Fig. 25. TM171PFE03 connection

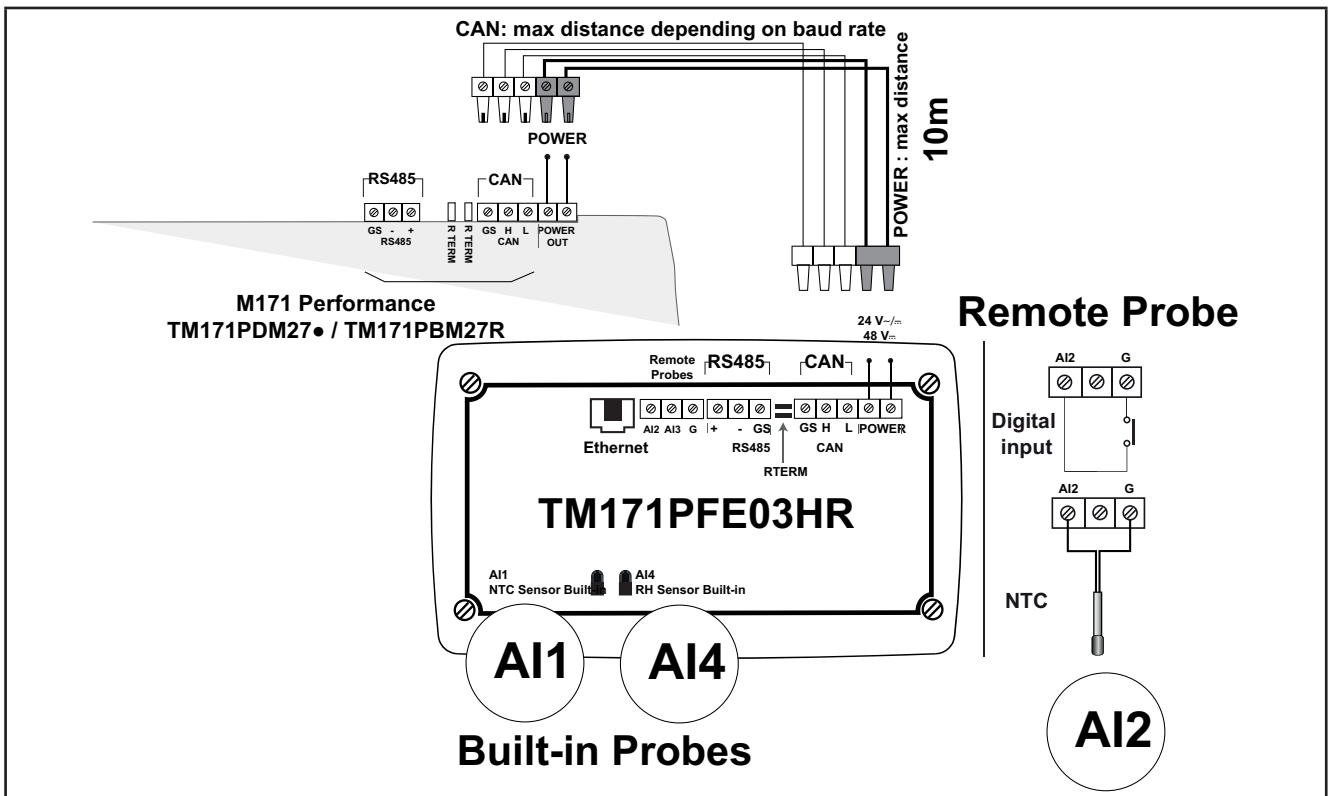

Fig. 26. TM171PFE03HR connection

**NOTE:** When supplying power from the **M171 Performance logic controllers**, make the power connection cable as short as possible.

## **NOTICE**

### **INOPERABLE EQUIPMENT**

Do not connect a power cable longer than 10m.

**Failure to follow these instructions can result in equipment damage.**

Label	Description	Notes
<b>POWER</b>	+24 Vac/dc or +48 Vdc power supply	Pin POWER Vout on <b>TM171PDM27●</b> / <b>TM171PBM27R</b> Max. distance 10m <b>M171 Performance Flush</b> / <b>TM171PDM27●</b> / <b>TM171PBM27R</b>
<b>CAN GS H L</b>	Isolated CAN serial GS ground serial isolated from G	R TERM termination resistors for CAN
<b>RS485 GS - +</b>	Isolated RS485 serial GS ground serial isolated from G	Apply 120 Ω terminal resistors
<b>Ethernet</b>	ETHERNET serial	-
<b>Built-in AI1 NTC Sensor</b>	On-board NTC sensor	-
<b>AI2 Remote Probes G</b>	NTC, D.I. remote Ground GND	Probe not included
<b>AI3 Remote Probes G</b>	4...20 mA / 0-10 V -+/ 0-5 V Ground GND	<b>TM171PFE03</b> Probe not included 12 V External power supply
<b>Built-in AI4 RH Sensor</b>	On-board RH% sensor	<b>TM171PFE03HR</b>

### 3.3. M171 Performance protocol connectivity

#### 3.3.1. Example: CAN (Field) network connection

A CAN (Field) network connection can be constituted by:

- Max 1 **M171 Performance TM171PDM27●** functioning as MASTER
- Max 12 **M171 Performance TM171EP●●R** functioning as SLAVES

**NOTE:** No more than two **M171 Performance Display Graphic (TM171DGRP)** can be added to the network connected to **M171 Performance TM171PDM27●**

The **M171 Performance Display Graphic (TM171DGRP)** is supplied by **TM171PDM27●** via the POWER OUT output.

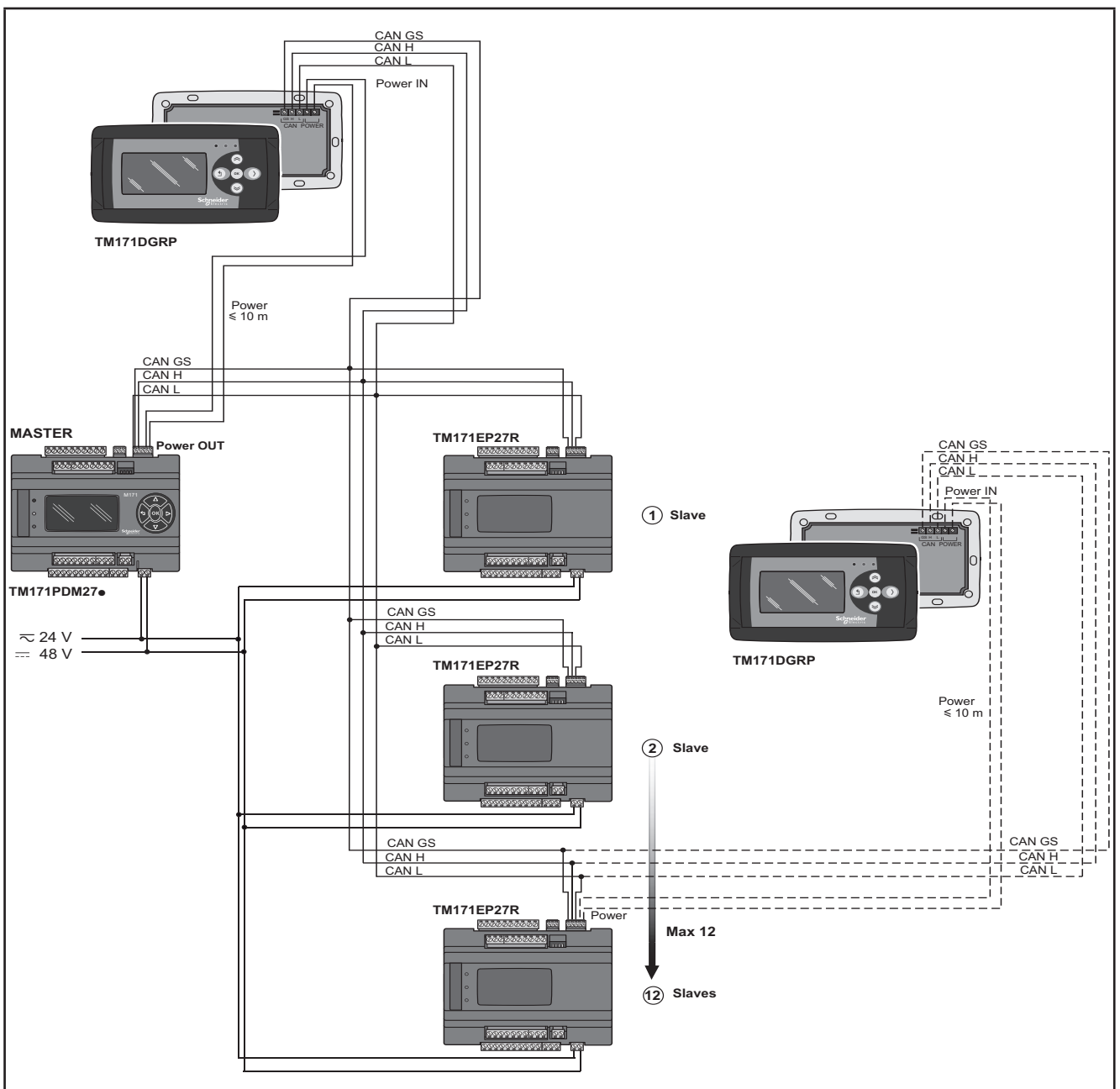

Fig. 27. CAN (Field) network connection using M171 Performance

### 3.3.2. Example: CAN connection (Network)

A CAN connection (Network) can be constituted by:

- 1 M171 Performance TM171PDM27●
- 1 M171 Performance Display Graphic (TM171DGRP) connected in CAN to M171 Performance TM171PDM27● or alternatively, to TM171PBM27R.

**NOTE:** Max 10 M171 Performance TM171PBM27R connected in CAN (binding).

The M171 Performance Display Graphic (TM171DGRP) is supplied by TM171PDM27● via the POWER OUT output.

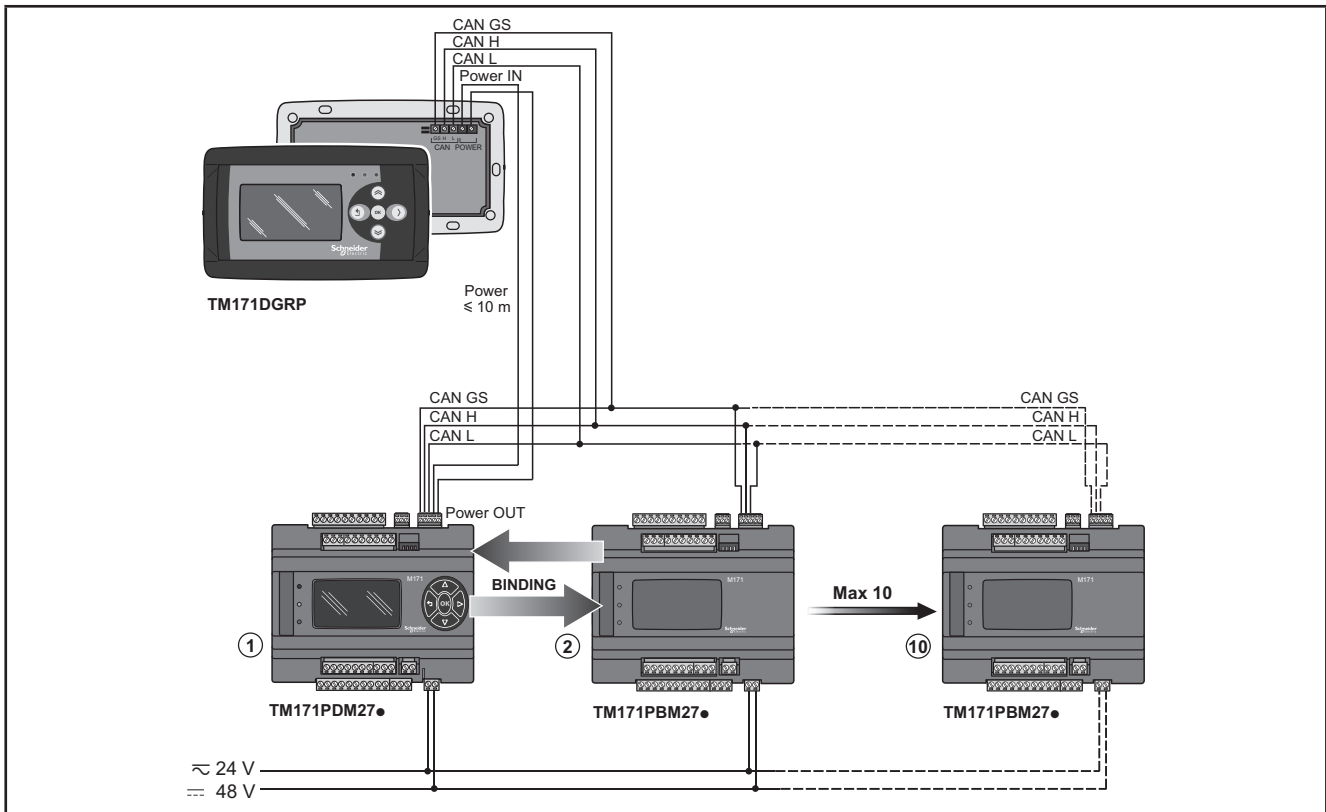

Fig. 28. CAN connection (Network) using M171 Performance

### 3.3.3. Example: RS485 connection (Field)

A RS485 connection (Field) can be constituted by:

Description	Notes
1 <b>M171 Performance TM171PDM27●</b>	<b>TM171PDM27●</b> is in Modbus RTU Master mode
Max 127 <b>M171 Performance TM171EP27R</b> expansion modules connected in RS485	<b>TM171EP27R</b> are in Modbus RTU Slave mode
1 <b>M171 Performance Display Graphic (TM171DGRP)</b> connected in CAN to <b>M171 Performance TM171PDM27●</b>	-

The **M171 Performance Display Graphic (TM171DGRP)** is supplied by **TM171PDM27●** via the POWER OUT output.

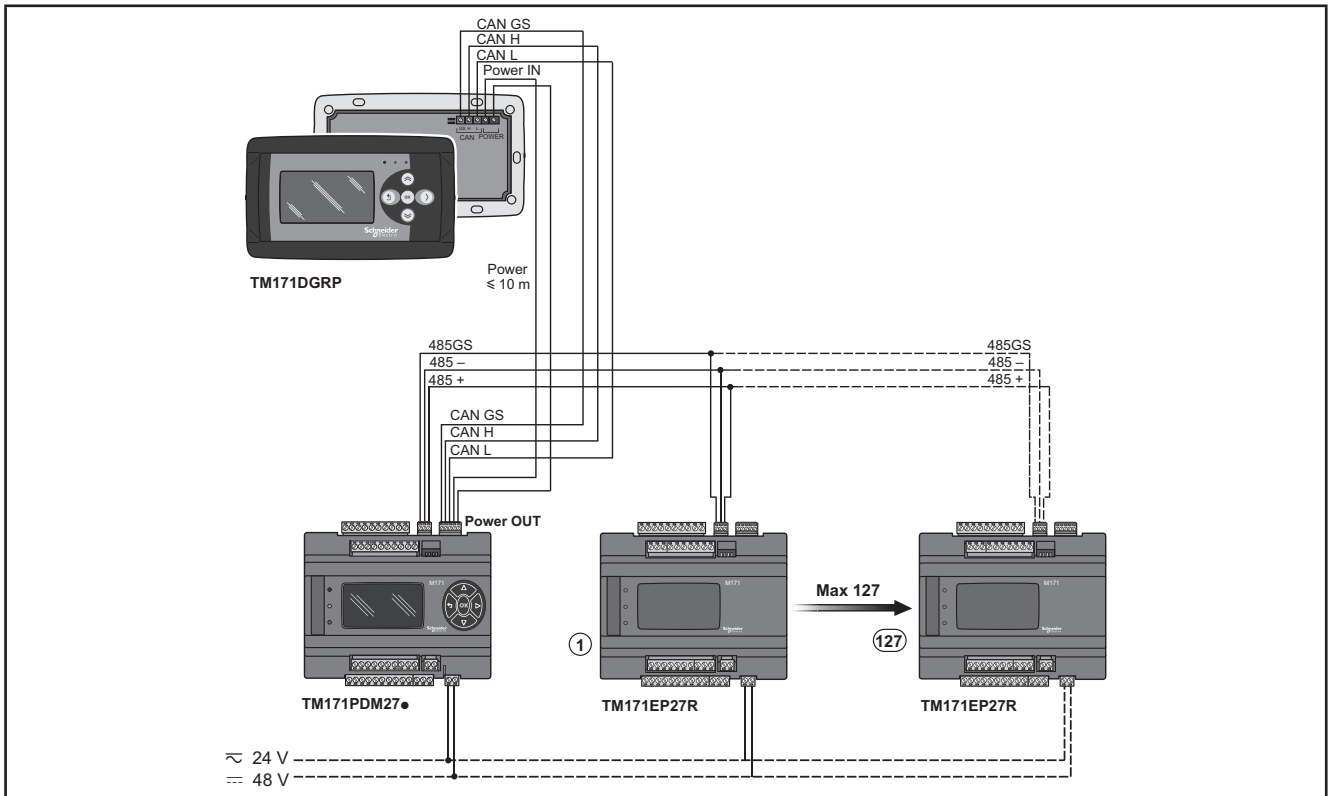

Fig. 29. RS485 connection (Field) using M171 Performance

### 3.3.4. Example: RS485 connection with the Modicon M171O network

A RS485 connection with the **Modicon M171O** network can be constituted by:

Description	Notes
<b>M171 Performance TM171PDM27●</b>	<b>TM171PDM27●</b> is in Modbus RTU Master mode
Max 127 <b>M171 Performance TM171PDM27● / TM171PBM27R or Modicon M171O (TM171O●M●●R / TM171ODM22S) (Modbus Slave)</b> or <b>Schneider Electric</b> and/or third-party devices equipped with RS485 serial	All devices equipped with RS485 are in Modbus RTU Slave mode (including the <b>M171 Performance</b> logic controllers) See also the <b>Modicon M171O</b> manual for further details.
CAN network – see <b>3.3.1. Example: CAN (Field) network connection on page 41.</b>	The CAN connection can be <ul style="list-style-type: none"> <li>• Field, as illustrated</li> <li>• Network, if one or more <b>M171 Performance TM171PDM27● / TM171PBM27Rs</b> are connected</li> </ul>
1 <b>M171 Performance Display Graphic (TM171DGRP)</b> connected in CAN to <b>M171 Performance TM171PDM27●</b>	-

The **M171 Performance Display Graphic (TM171DGRP)** is supplied by **TM171PDM27●** via the POWER OUT output.

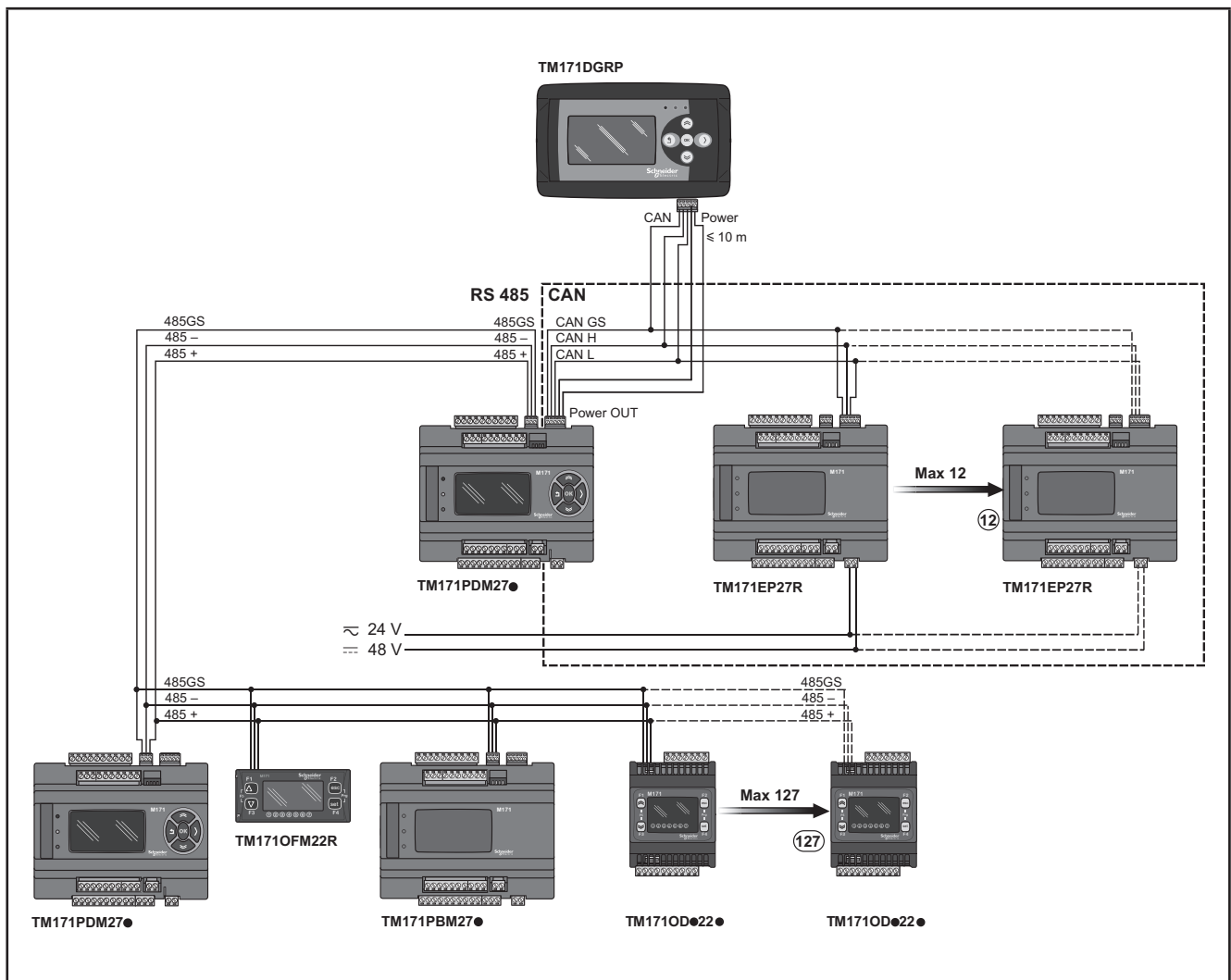

**Fig. 30.** RS485 connection with the Modicon M171O network using M171 Performance

### 3.4. M171 Performance Flush protocol connectivity

#### 3.4.1. Example: RS485 connection (Field)

A RS485 connection (Field) can be constituted by:

Description	Notes
1 M171 Performance Flush	M171 Performance Flush is in Modbus RTU Master mode
Max 127 M171 Performance TM171EP27R expansion modules connected in RS485	TM171EP27R are in Modbus RTU Slave mode

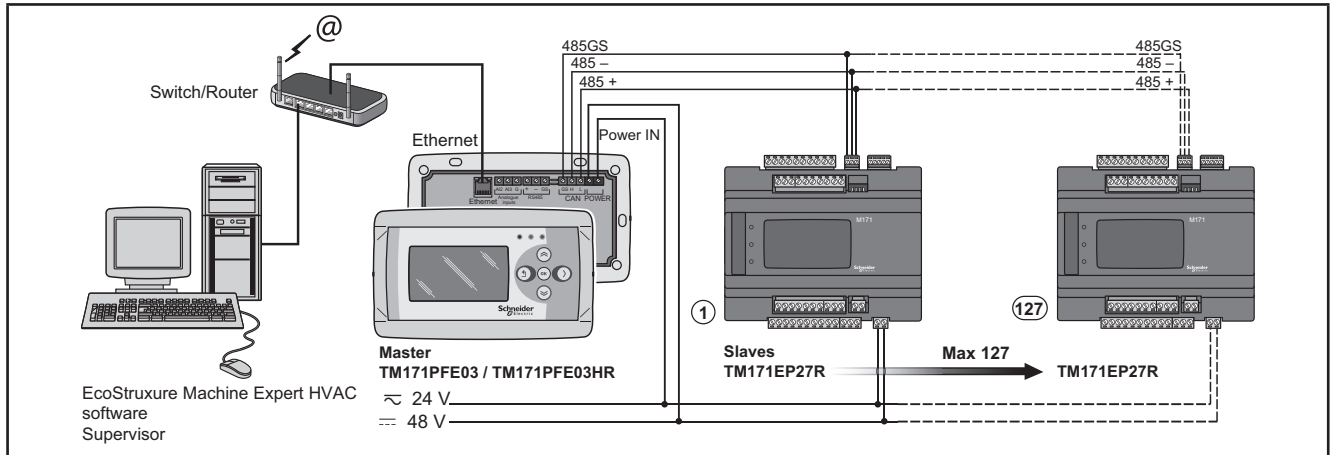

Fig. 31. RS485 connection (Field) using M171 Performance Flush

#### 3.4.2. Example: CAN connection

A CAN connection can be constituted by 1 M171 Performance Flush.

**NOTE:** Max 12 M171 Performance TM171EP●●R expansion modules connected in CAN.

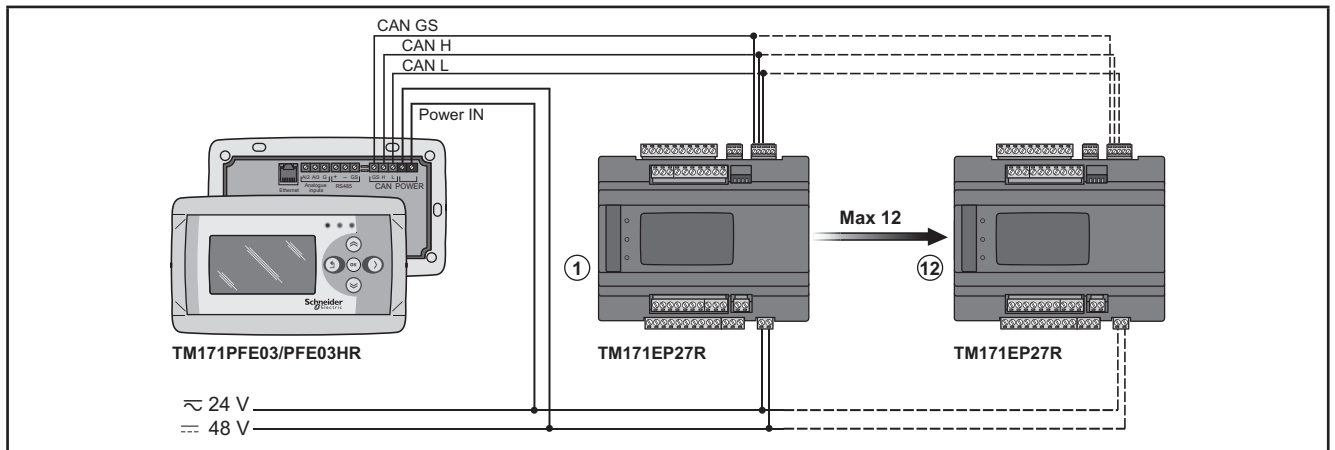
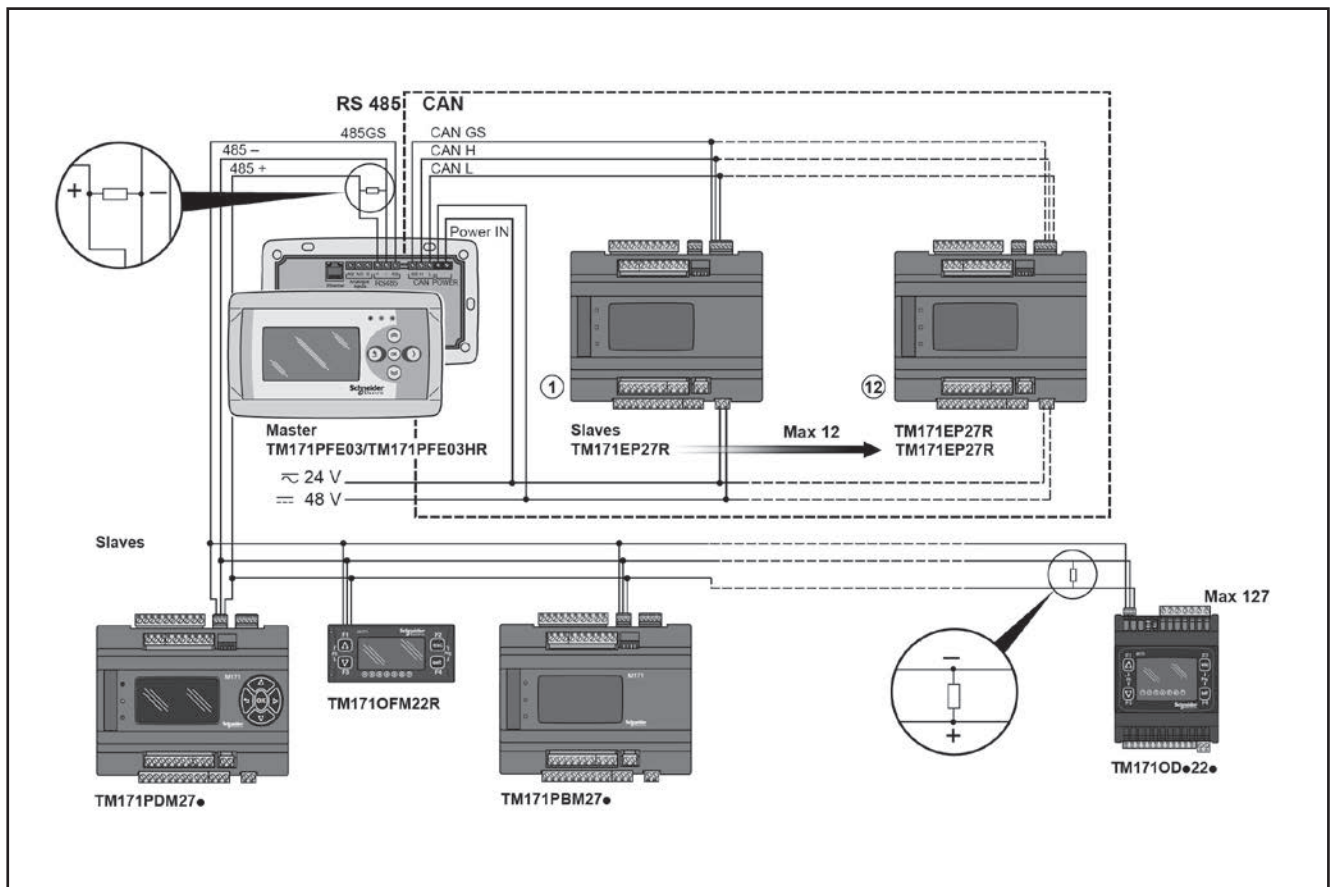

Fig. 32. CAN connection using M171 Performance Flush

### 3.4.3. Example: RS485 connection with the Modicon M171O network

A RS485 connection with the **Modicon M171O** network can be constituted by:

Description	Notes
1 M171 Performance Flush	<b>M171 Performance Flush</b> is in Modbus RTU Master mode
Max 127 M171 Performance TM171PDM27● /TM171PBM27R or Modicon M171O or Schneider Electric and/or third-party equipment equipped with RS485 serial	All devices equipped with RS485 are in Modbus RTU Slave mode (including the <b>M171 Performance</b> logic controllers) See also the <b>Modicon M171O</b> manual for further details.
CAN network	see <a href="#">3.4.2. Example: CAN connection on page 45</a>



**Fig. 33.** RS485 connection with the Modicon M171O network using M171 Performance Flush

### 3.4.4. Example: CAN network connection

A CAN network connection can be constituted by 1 **M171 Performance Flush**.

**NOTE:** Max 10 **M171 Performance TM171PDM27● / TM171PBM27R**.

**NOTE:** CAN network: see **3.4.2. Example: CAN connection on page 45**

#### HMI menu

**M171 Performance Flush** can be equipped with its own menu (named Network menu).

In this case **M171 Performance Flush logic controller** is programmed with the network menu, which can read variables present in the **M171 Performance logic controller** network.

**M171 Performance Flush** logic controller can operate from the individual controllers and download up to 10 remote menus from the respective **M171 Performance logic controllers**.

In this case the remote menu allows 'local' navigation of the individual **M171 Performance logic controller**.

#### Controller application

The variables of the various controllers are shared (bound together).

An application present on **M171 Performance Flush** logic controller can use variables present in the network and share its own variables with other applications present on the respective **M171 Performance logic controllers**.

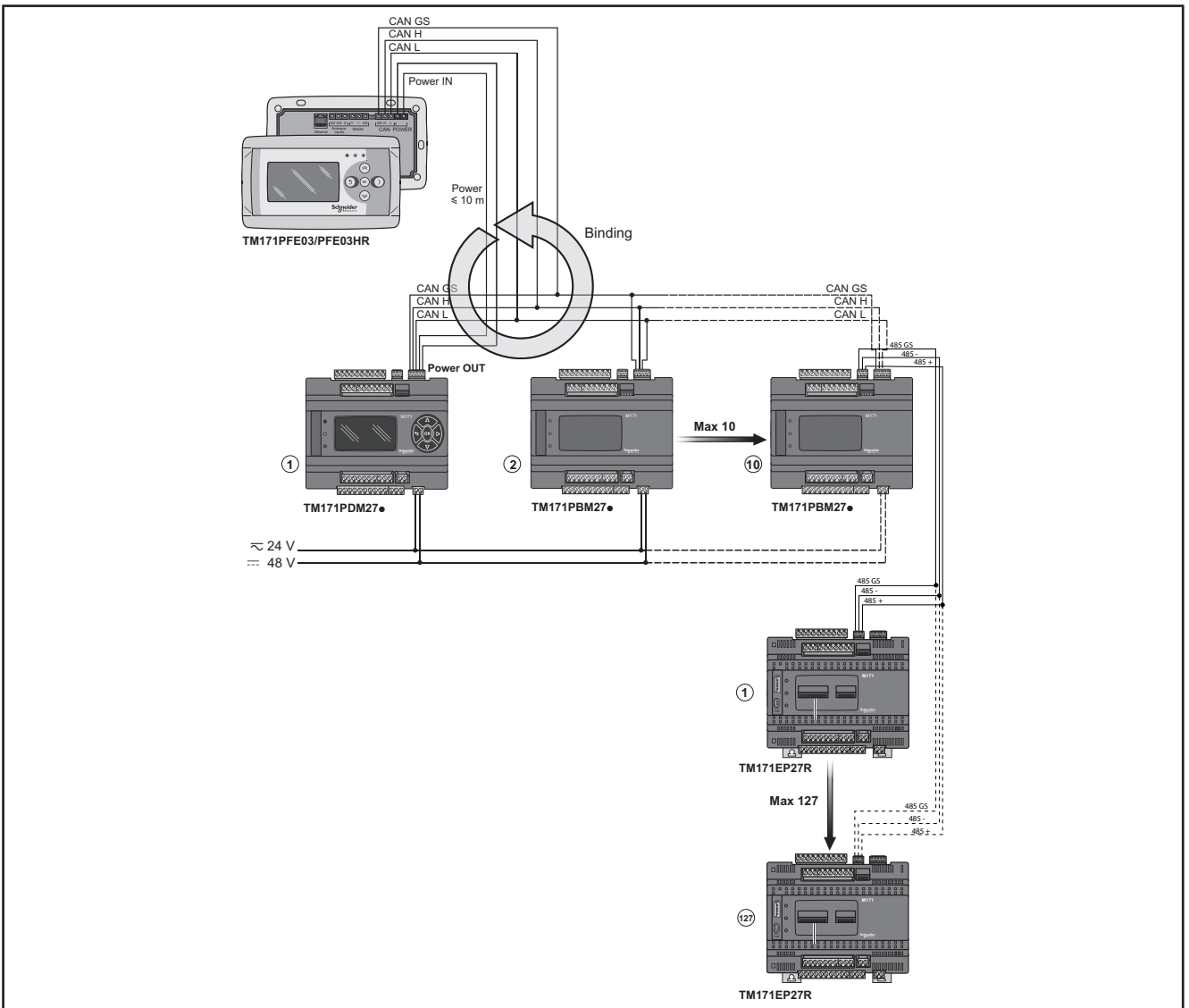

**Fig. 34.** CAN network connection using M171 Performance Flush

---

### 3.5. TM171A●●●● Communication Modules

Communication Modules are 2DIN modules that can be connected to an **M171 Performance** controller or an M172 Performance controller (with restrictions, refer to the M172 Performance controller Hardware Guide) via the Communication Module connector on the left side, behind the removable door. The Communication Module is anchored to the controller with the two fixing hooks.  
It mounts to the DIN rail in the same way as the controller.

#### 3.5.1. Communication Modules compatible with M171 and M172

Interface for	Communication Module	
RS 232	TM171ARS232	5A SPDT relay available
RS 485	TM171AMB TM171ARS485	RS 485 in Daisy Chain(1)
CAN Expansion Bus	TM171ACAN	CAN Expansion Bus in Daisy Chain(1)
LON	TM171ALON	LonWorks Communication Module

(1) Use a shielded cable. See **3.1.6. Serial connections on page 28**.

**NOTE:** The LonWorks communication module supports up to 63 nodes. Exceeding this specification may result in an electrical overload condition in the M171ALON Communication Module and consequently in the controller.

<b>⚠ WARNING</b>
<b>UNINTENDED EQUIPMENT OPERATION</b> Do not exceed the maximum of 63 nodes on the TM171ALON Communication Module. <b>Failure to follow these instructions can result in death, serious injury, or equipment damage.</b>

For more information on the LonWorks network, visit [www.echelon.com/technology/lonwork/](http://www.echelon.com/technology/lonwork/)

### 3.5.2. Communication Modules exclusively compatible with M171

Interface for	Communication Module	
ETHERNET	TM171AETH TM171AETHRS485	The MACADDRESS is supplied in the box, Expressed as barcode and 12-digit alphanumeric code. The Ethernet connector shield is connected internally to the equipment ground, and therefore to the reference of the input and output channels
		<b>WebVisu:</b> WEB functionalities of <b>M171 Performance TM171PDM27●</b> or <b>TM171PBM27R + TM171AETH/ TM171AETHRS485</b> Communication Module
PROFIBUS	TM171APBUS Profibus DP Slave-V0	Contact your local Schneider Electric representative for more information concerning the .GSD Profibus configuration file
		See official Profibus documentation for more detailed information

Communication Module **TM171A●●●●** are shown below:

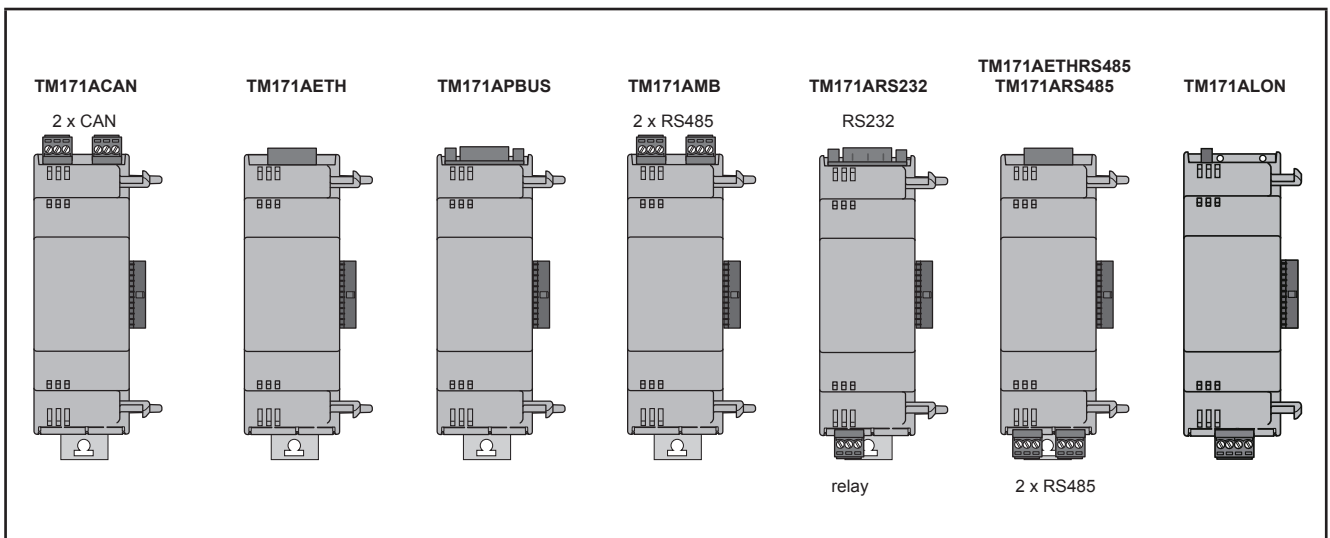
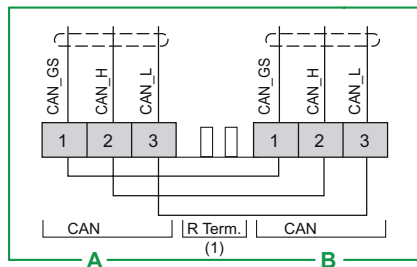
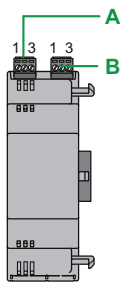

Fig. 35. TM171A●●●● Communication Modules

**TM171ACAN**



(1) CAN terminal resistance.

**TM171ALON**

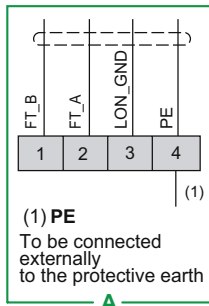
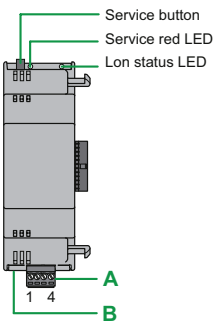

**RT1 AND RT2 terminators**

RT1 mounted	RT2 mounted	Termination resistance value
YES	YES	52.5 Ohm
YES	NO	105 Ohm
NO	NO	No termination

**TM171ARS485**

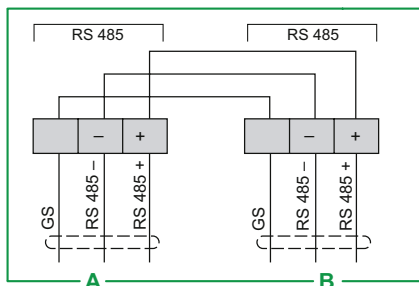
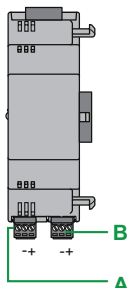

**TM171AMB**

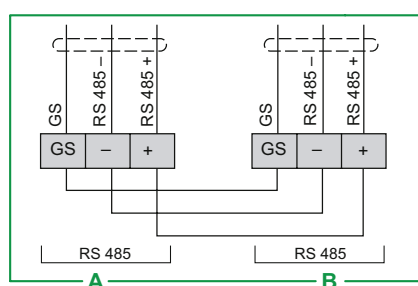
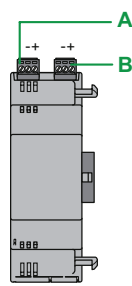

**TM171ARS232**

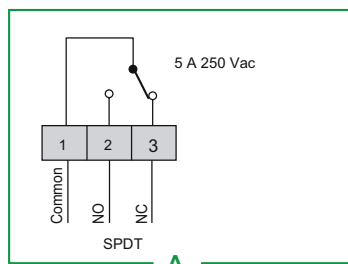
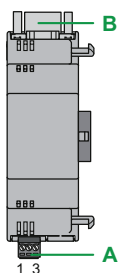

**RS 232**

N°	RS232
1	GND
2	DTR
3	TXD
4	RXD
5	DCD
6	RI
7	CTS
8	RTS
9	DSR

Sub-DB9

**Fig. 36.** Communication Modules compatible with M171/M172

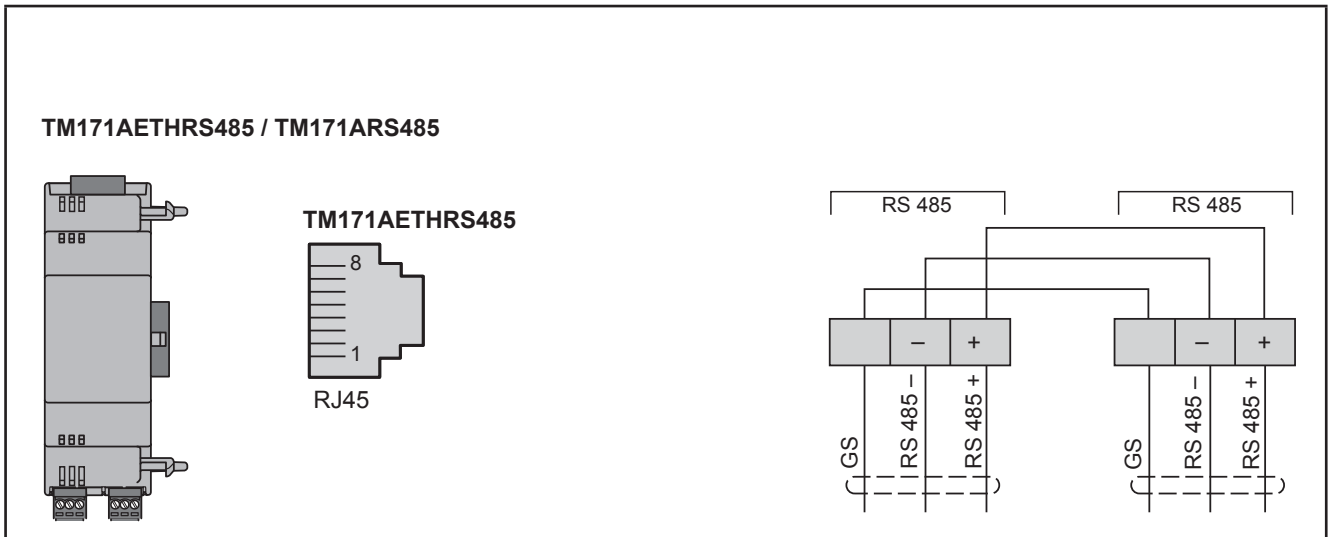

**Fig. 37.** ETHERNET, ETHERNET+RS485 Communication Modules

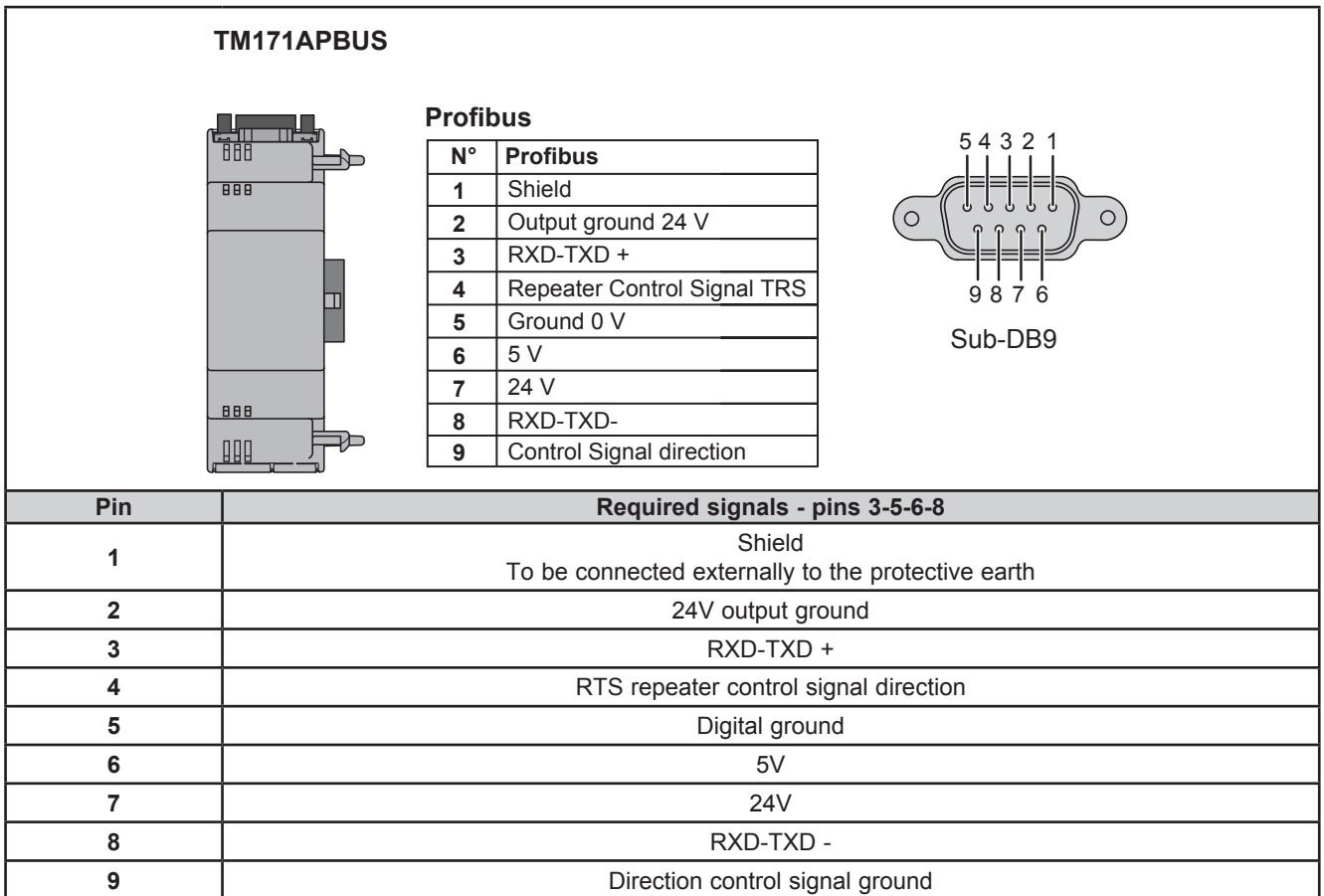

**Fig. 38.** PROFIBUS Communication Module

**NOTE:** In a network with Profibus Communication Modules, the first and last element in the network must terminate with Profibus resistors.

### 3.5.3. TM171ARS232

The RS232 Communication Module allows **M171/M172** DIN rail mounted Performance controllers to communicate via an RS232 serial.

#### Modbus RTU communication protocol

The connection allows:

- connection to a supervision system using the Modbus RTU protocol
- connection of an IEC 61131-3 **EcoStruxure Machine Expert HVAC** development system

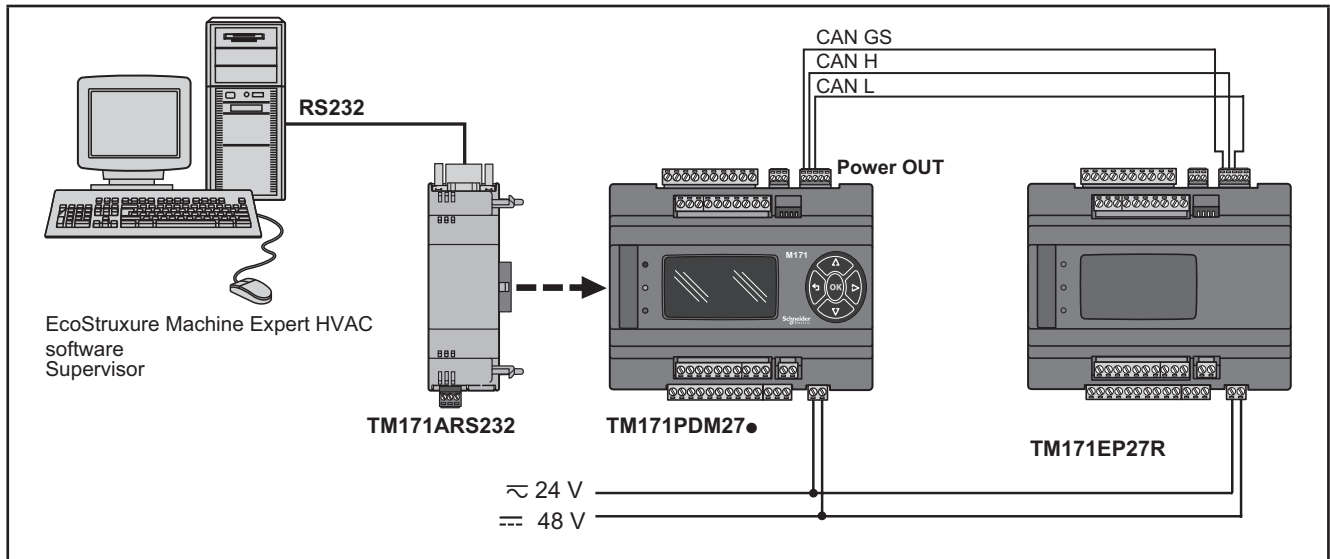

Fig. 39. Modbus RTU communication protocol using TM171ARS232

## Modbus ASCII communication protocol send/receive AT commands for modem<sup>(1)</sup>

This protocol activates when there is a modem connected to the Communication Module.  
The connection allows:

- connection to a monitoring system using the Modbus ASCII protocol;
- connection of an IEC 61131-3 **EcoStruxure Machine Expert HVAC** development system;
- send/receive TXT messages via a modem connected to the RS232<sup>(2)</sup> port.

**NOTE:** The Communication Module has a relay that can be piloted from the controller application to allow the modem to be activated/reset or as an additional digital output.

<sup>(1)</sup> Refer to the **Modem\_IEC.pll** software library in

C:\Program Files (x86)\Schneider Electric\EcoStruxureMachineExpertHVAC\Catalog\FreeEvolution\PLC

<sup>(2)</sup> Refer to the **SMS\_IEC.pll** software library in

C:\Program Files (x86)\Schneider Electric\EcoStruxureMachineExpertHVAC\Catalog\FreeEvolution\PLC

See **EcoStruxure Machine Expert HVAC** Manual for details.

### NOTE:

Refer to the section on Parameters / RS232 PASSIVE PLUG-IN folder (see **CHAPTER 9 Parameters on page 103**).

Refer to the section on Parameters / MODEM folder (see **CHAPTER 9 Parameters on page 103**).

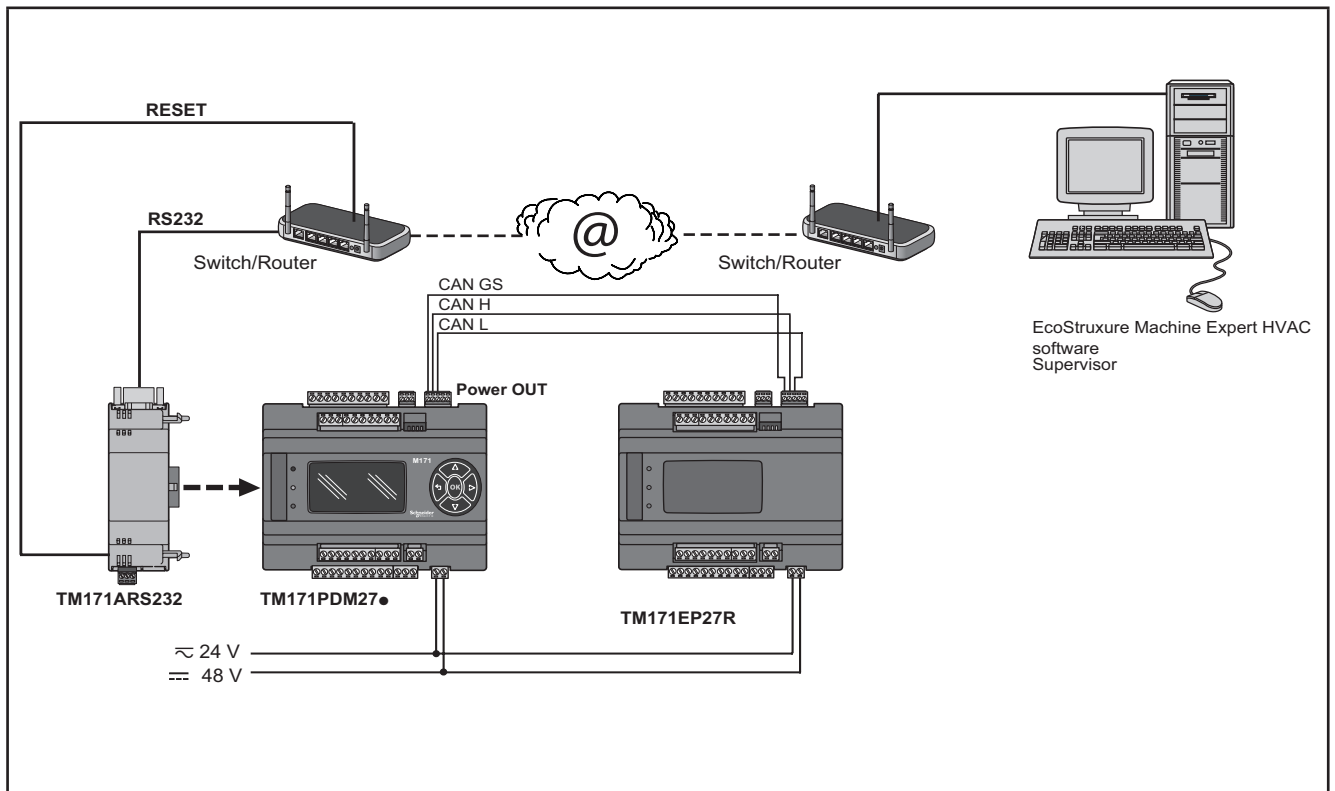

**Fig. 40.** Modbus ASCII communication protocol using TM171ARS232

### 3.5.4. TM171AETH / TM171AETHRS485

The Ethernet Communication Module enables communication of the **M171 Performance TM171PDM27● / TM171PBM27R** on an Ethernet network using the Modbus TCP protocol.

The connection allows:

- network connection of different controllers and/or applications exchanging variables and/or parameters (**network**)
- connection to a supervision system using the Modbus TCP protocol
- connection of an IEC 61131-3 **EcoStruxure Machine Expert HVAC** development system

**NOTE:**

The MAC ADDRESS (barcode and 12-digit alphanumeric code) is supplied in the box containing the Ethernet Communication Module.

Refer to the section on Parameters / ETHERNET PASSIVE PLUG-IN folder (see **CHAPTER 9 Parameters on page 103**).

**NOTE:** The Ethernet connector shield is connected internally to the functional ground, and therefore to the reference of the input and output channels. Care must be taken to the fact there may be within the Ethernet communications system other grounding points. Interconnection of multiple protective earth grounding points in the same installation can cause current loops and voltage shifts across conductive parts of the equipment.

**⚠ WARNING**

**UNINTENDED EQUIPMENT OPERATION**

Do not connect the connector shield to protective earth (PE) or to functional earth (FE) of your installation.

**Failure to follow these instructions can result in death, serious injury, or equipment damage.**

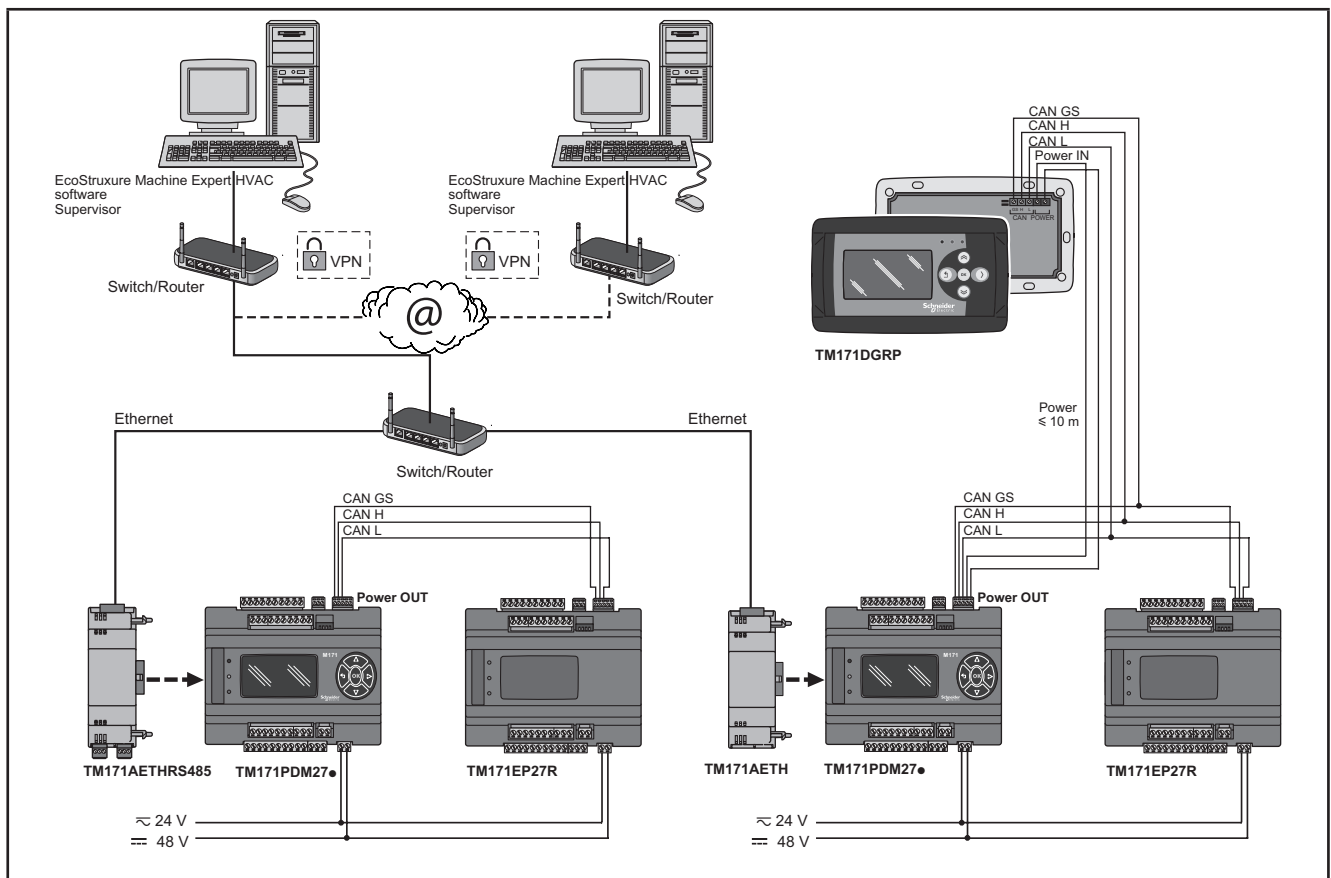

**Fig. 41.** Modbus TCP protocol using TM171AETH

VPN is not necessary when using DynDNS connection.

Protocol	Field	Network
Modbus TCP	-	Max 10 <b>M171 Performance</b> + 2 <b>M171 Performance Display Graphic</b> (TM171DGRP) Max Modbus Messages = 128 / number of <b>M171 Performance</b> connected

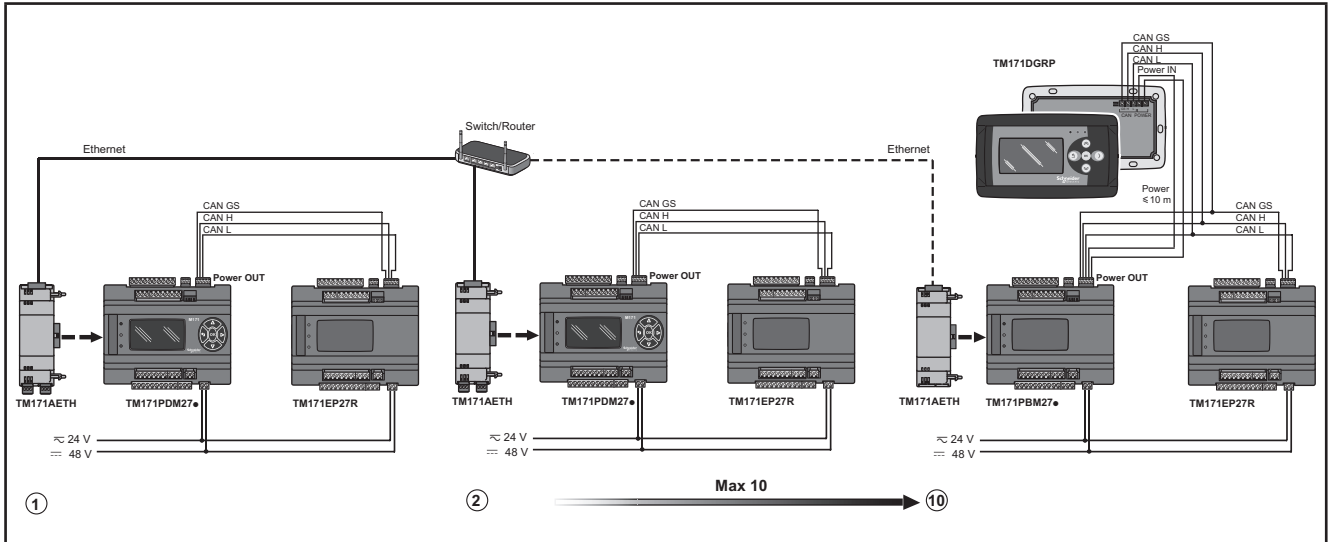

Fig. 42. Modbus TCP protocol using TM171AETH - limits

### 3.5.5. Example: BACnet / IP

Protocol	Field	Network
BACnet IP	-	Max 4 <b>M171 Performance</b>

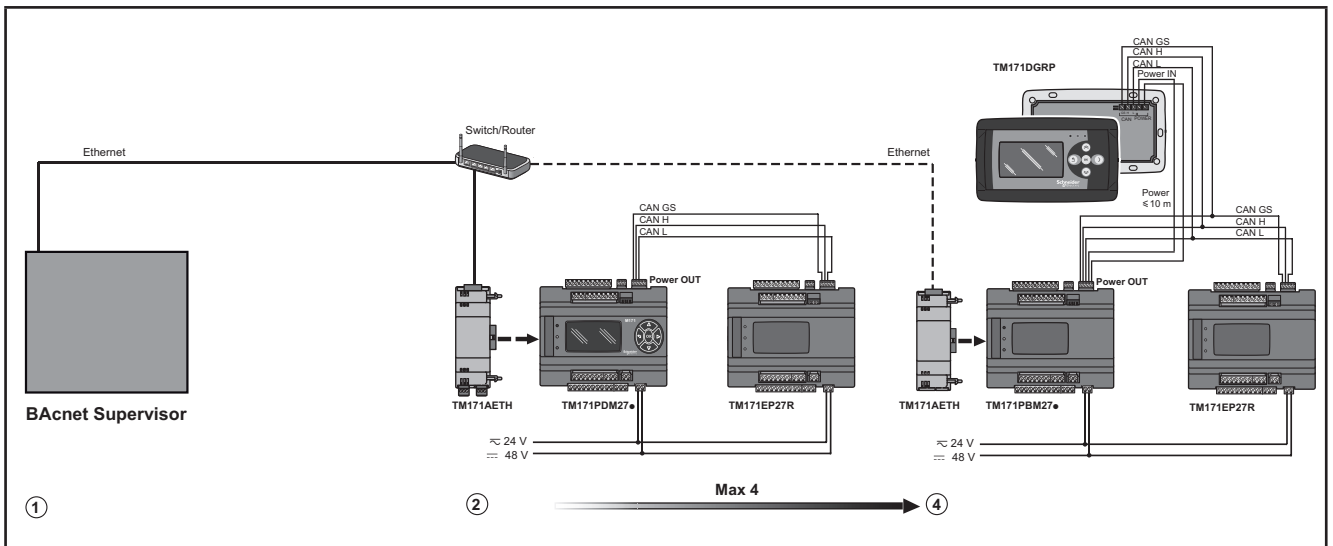

Fig. 43. BACnet IP protocol using Ethernet port of the M171 Performance

## WebVisu (WEB SERVER HTTP)

**WebVisu** is an **M171 Performance TM171PDM27●**, **TM171PBM27R** with the **TM171AETH Communication Module**. The Ethernet Communication Module also uses HTTP protocol, i.e. allowing access to a Web Server contained in **M171 Performance**.

**EcoStruxure Machine Expert HVAC** allows the creation and management of web pages internally of **WebVisu (WEB SERVER HTTP)**, i.e. a website in miniature.

WEB functionalities allow local and remote access by way of an ordinary browser. Thanks to the web connection, the system provides reading, support and diagnostics services, as well as e-mail alarm alerts.

Main web functionalities:

- Web-based access.
- Remote reading and support.
- Local and remote system control, including alarms management.
- Preventive and predictive maintenance.
- Email alarm alerts.

Care must be taken and provisions made for use of this product as a control device to avoid inadvertent consequences of commanded machine operation, controller state changes, or alteration of data memory or machine operating parameters.

### ⚠ WARNING

#### UNINTENDED EQUIPMENT OPERATION

- Configure and install the mechanism that enables the remote HMI local to the machine, so that local control over the machine can be maintained regardless of the remote commands sent to the application.
- You must have a complete understanding of the application and the machine before attempting to control the application remotely.
- Take the precautions necessary to assure that you are operating remotely on the intended machine by having clear, identifying documentation within the application and its remote connection.

**Failure to follow these instructions can result in death, serious injury, or equipment damage.**

Refer to the section on Parameters / ETHERNET PASSIVE PLUG-IN folder (see **CHAPTER 9 Parameters on page 103**).

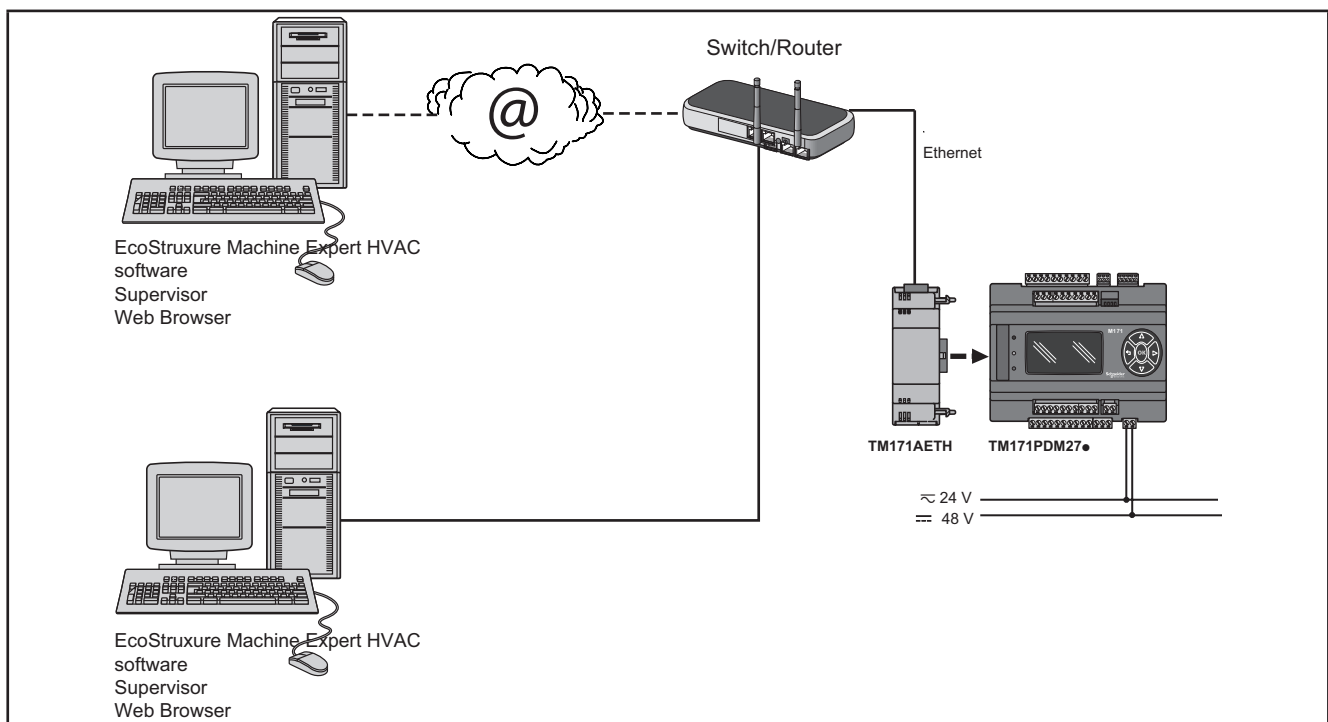

**Fig. 44.** WebVisu (WEB SERVER HTTP) using M171 Performance and TM171AETH

## BRIDGE

**EcoStruxure Machine Expert HVAC** allows monitoring of the **Modicon M1710** or M171P controller or third party devices, typically Modbus/RTU slaves, where **WebVisu** (or **M171 Performance** with **TM171AETH** Communication Module) is the Master Modbus/RTU.

In a **EcoStruxure Machine Expert HVAC** project, more exactly, **WebVisu** is used as a Modbus/TCP to Modbus/RTU protocol conversion element for Modbus 0x03 and 0x10 commands.

For example from **EcoStruxure Machine Expert HVAC**, set the connection with the **Modicon M1710** as Modbus/TCP, inserting the **WebVisu** IP address and the Modbus/RTU address of the **Modicon M1710** slave.

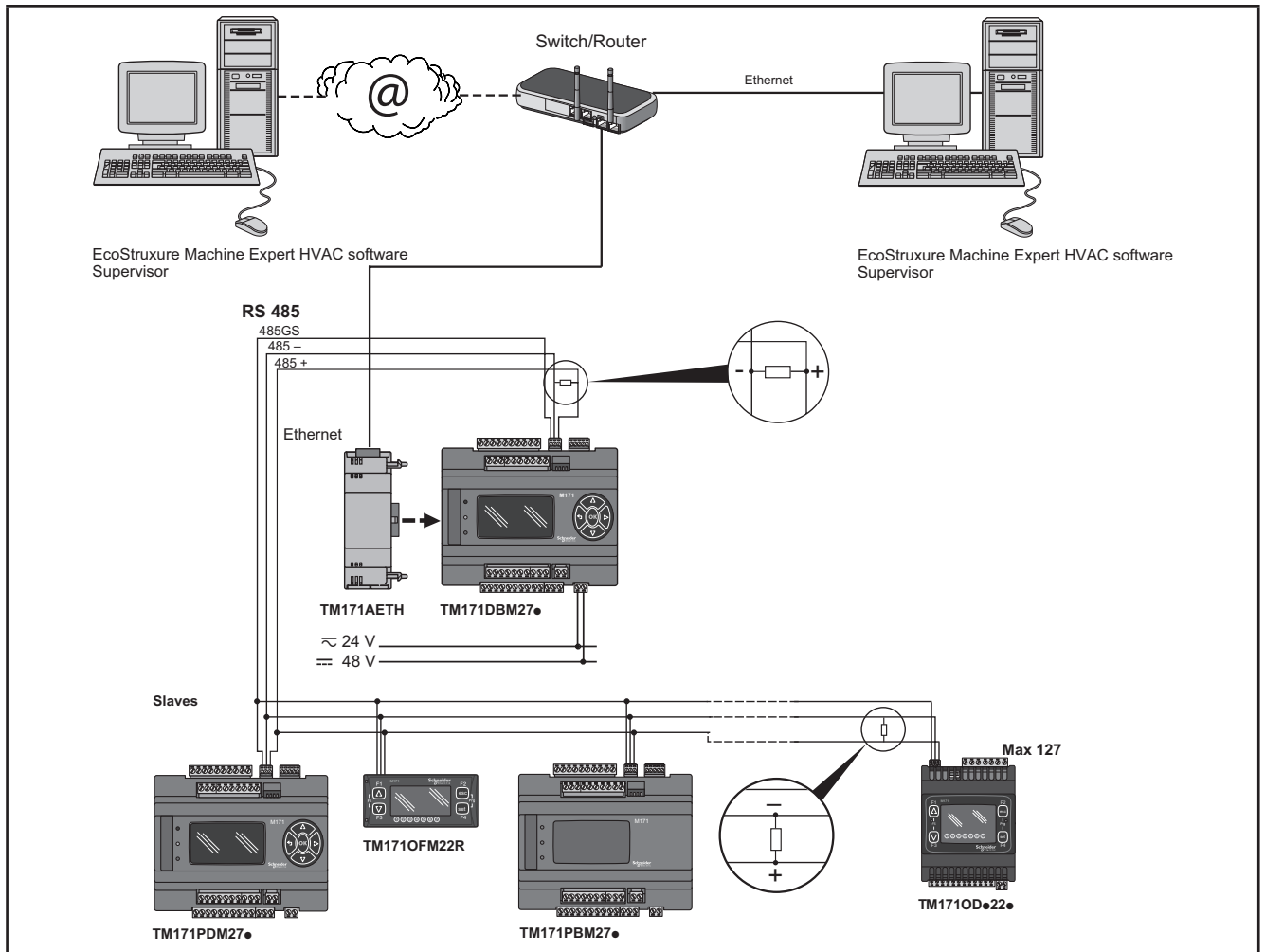

Fig. 45. BRIDGE using TM171AETH

## TFTP (Trivial File Transfer Protocol)

TFTP can also be enabled for file transfer between PC and controller on an Ethernet network.

### 3.5.6. TM171AMB

The RS485 Communication Module allows **M171/M172** DIN rail mounted Performance controllers to communicate via an RS485 serial using a Modbus RTU Master/Slave communication protocol, in addition to the RS485 serial.

The connection allows:

- connection to a supervision system using the Modbus RTU protocol
- connection of an IEC 61131-3 **EcoStruxure Machine Expert HVAC** development system
- connection to peripheral Modbus devices (for example **TM171EP●●R**)

The two CAN serials ports (integrated and communication module) offer the same level of services.

**M171 Performance** manages only one of the two as Modbus Master. Both can operate as a Modbus Slave.

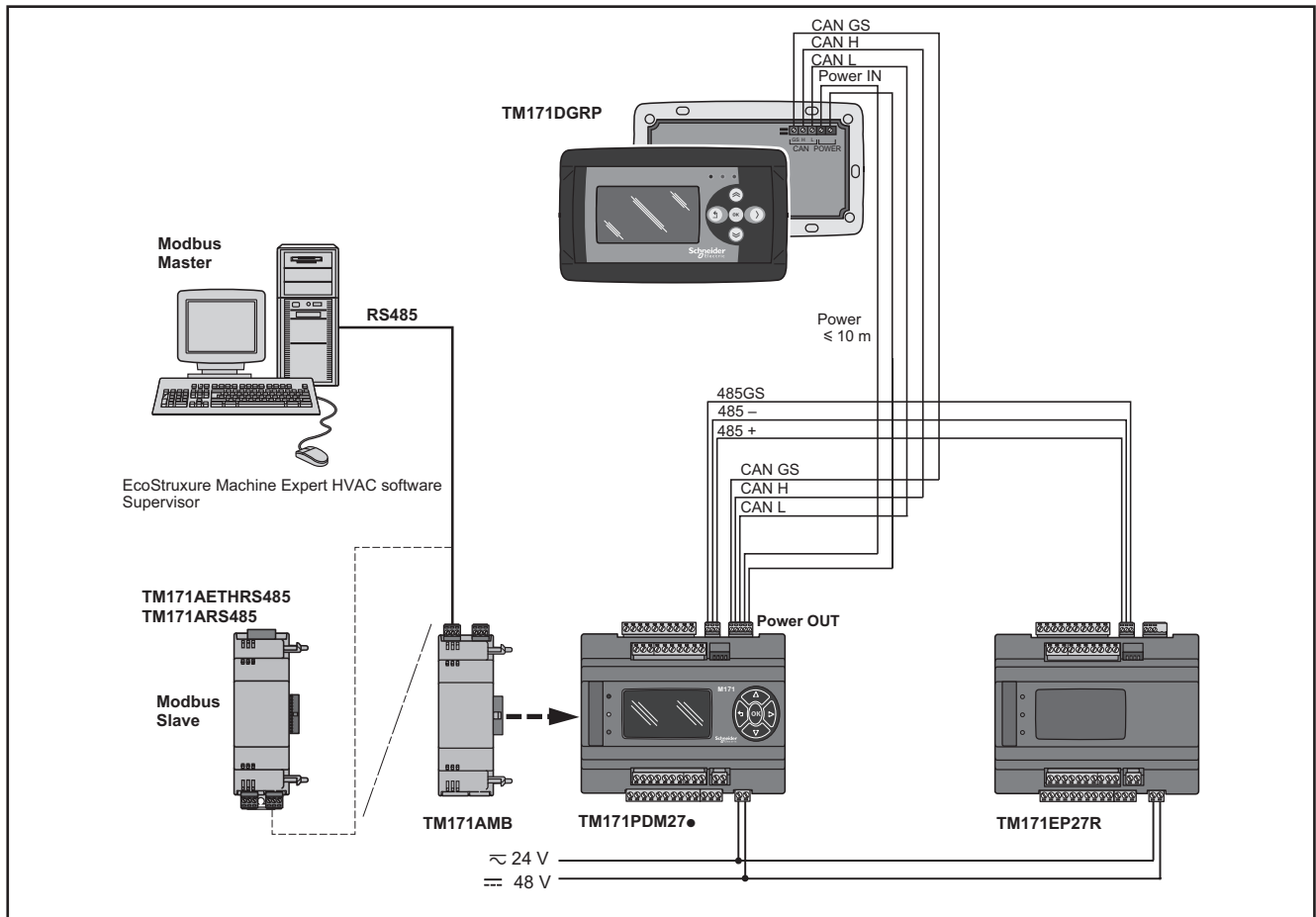
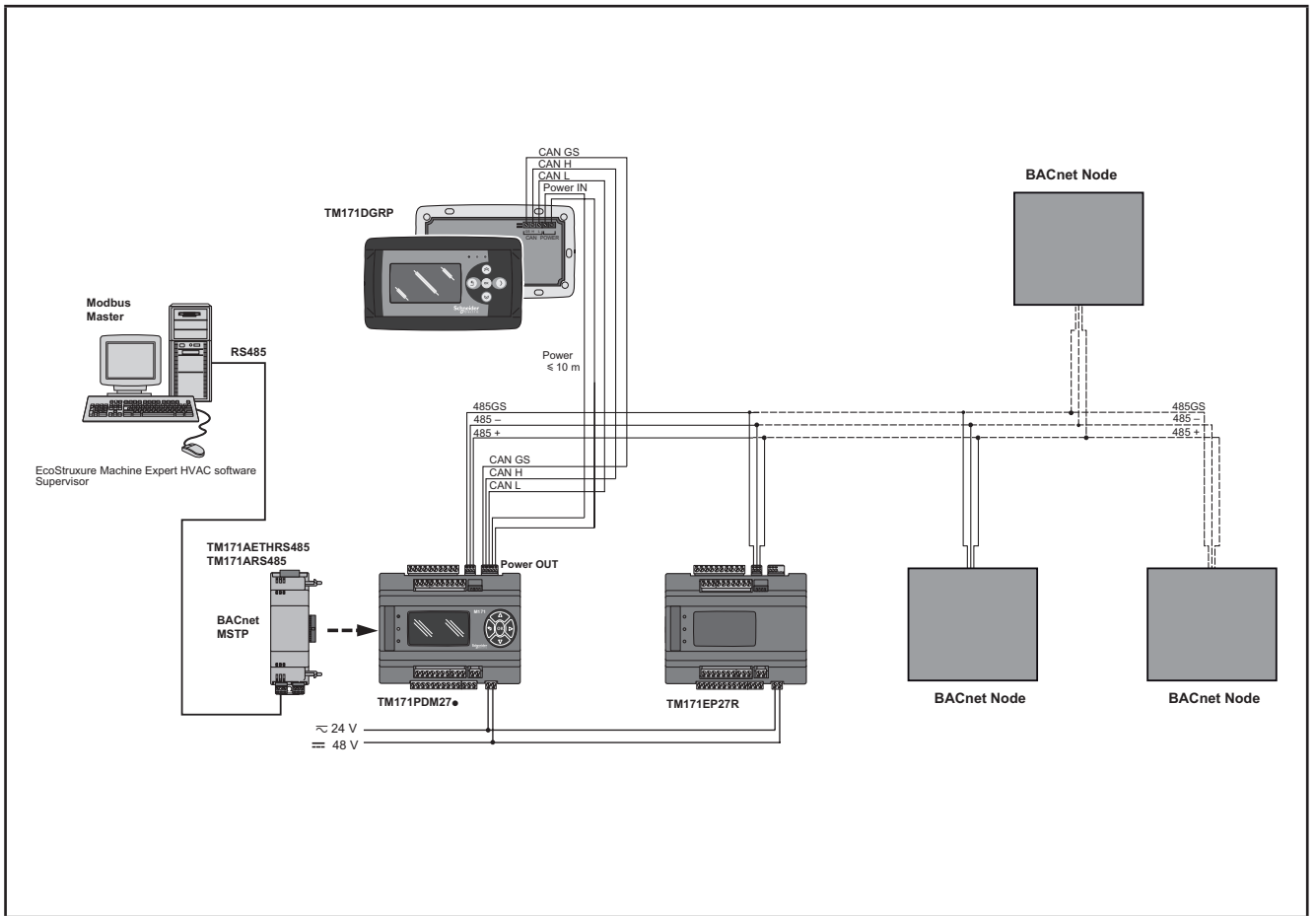

Fig. 46. Modbus RTU protocol using TM171AMB

### 3.5.7. TM171ARS485 / TM171AETHRS485

The connection allows **M171 Performance** controllers to connect to a BACnet supervision system using the BACnet MS/TP communication protocol.



**Fig. 47.** BACnet MS/TP on RS 485 network using TM171ARS485 / TM171AETHRS485

### 3.5.8. TM171ACAN

The CAN Communication Module allows **M171/M172** DIN rail mounted Performance controllers to communicate via a CAN serial using a CAN protocol in addition to the existing CAN serial.

It allows:

- connection to a supervision system using the CAN protocol.
- connection of an IEC 61131-3 **EcoStruxure Machine Expert HVAC** development system.
- connection to **TM171EP●●R** expansions.
- connection to **M171 Performance Display Graphic** (TM171DGRP) devices.

The two CAN serials ports (integrated and communication module) offer the same level of services. **M171 Performance** manages only one of the two to pilot expansions.

Refer to the section on Parameters / CAN PASSIVE PLUG-IN folder (see **CHAPTER 9 Parameters on page 103**).

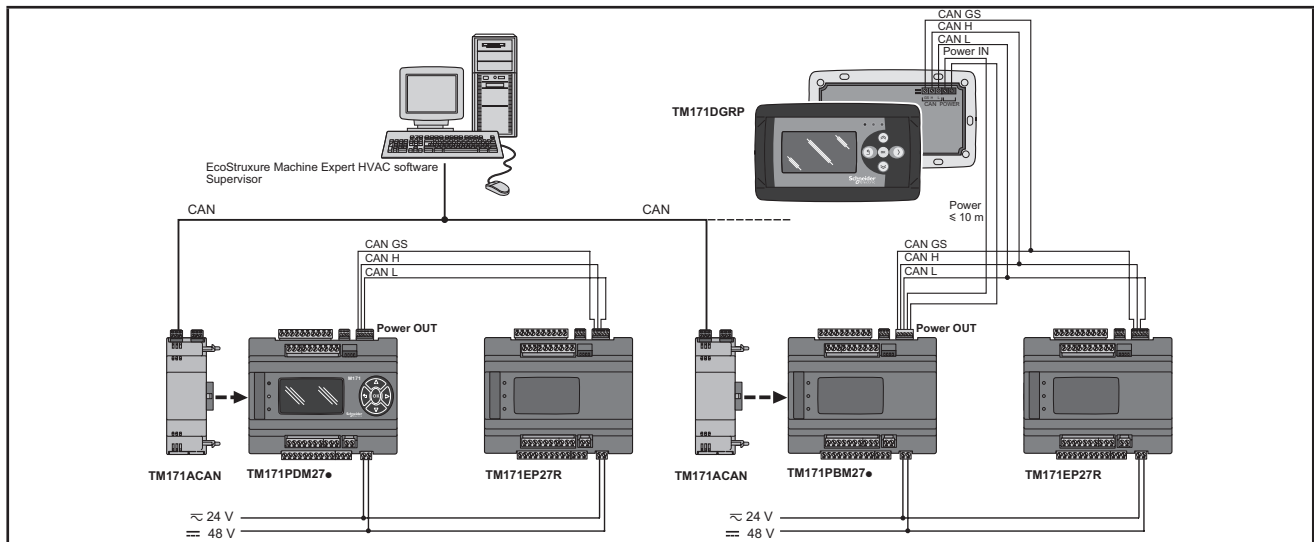

**Fig. 48.** CAN protocol using TM171ACAN

### 3.5.9. TM171APBUS

The PROFIBUS Communication Module allows **M171 Performance TM171PDM27●** and **TM171PBM27R** to communicate via a Profibus serial using the Profibus DP Slave V-0 communication profile. The connection allows interface with a supervision system or master controller using the Profibus protocol.

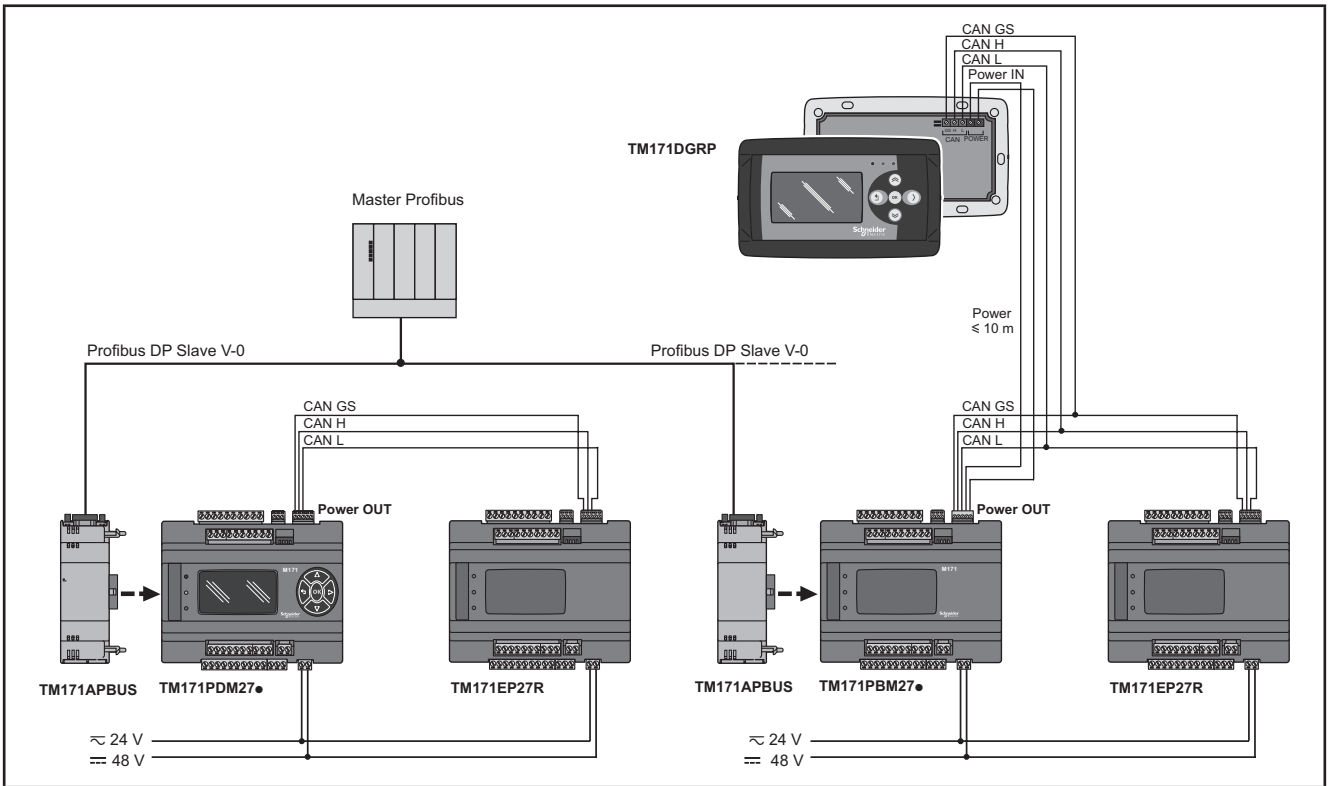

Fig. 49. Profibus protocol using TM171APBUS

### 3.5.10. TM171ALON

The LON Communication Module allows **M171/M172** DIN rail mounted Performance controllers to communicate via a LON serial using the LonWorkS (FFT-10) communication profile. The connection allows interface with a supervision system or master controller using the LON protocol.

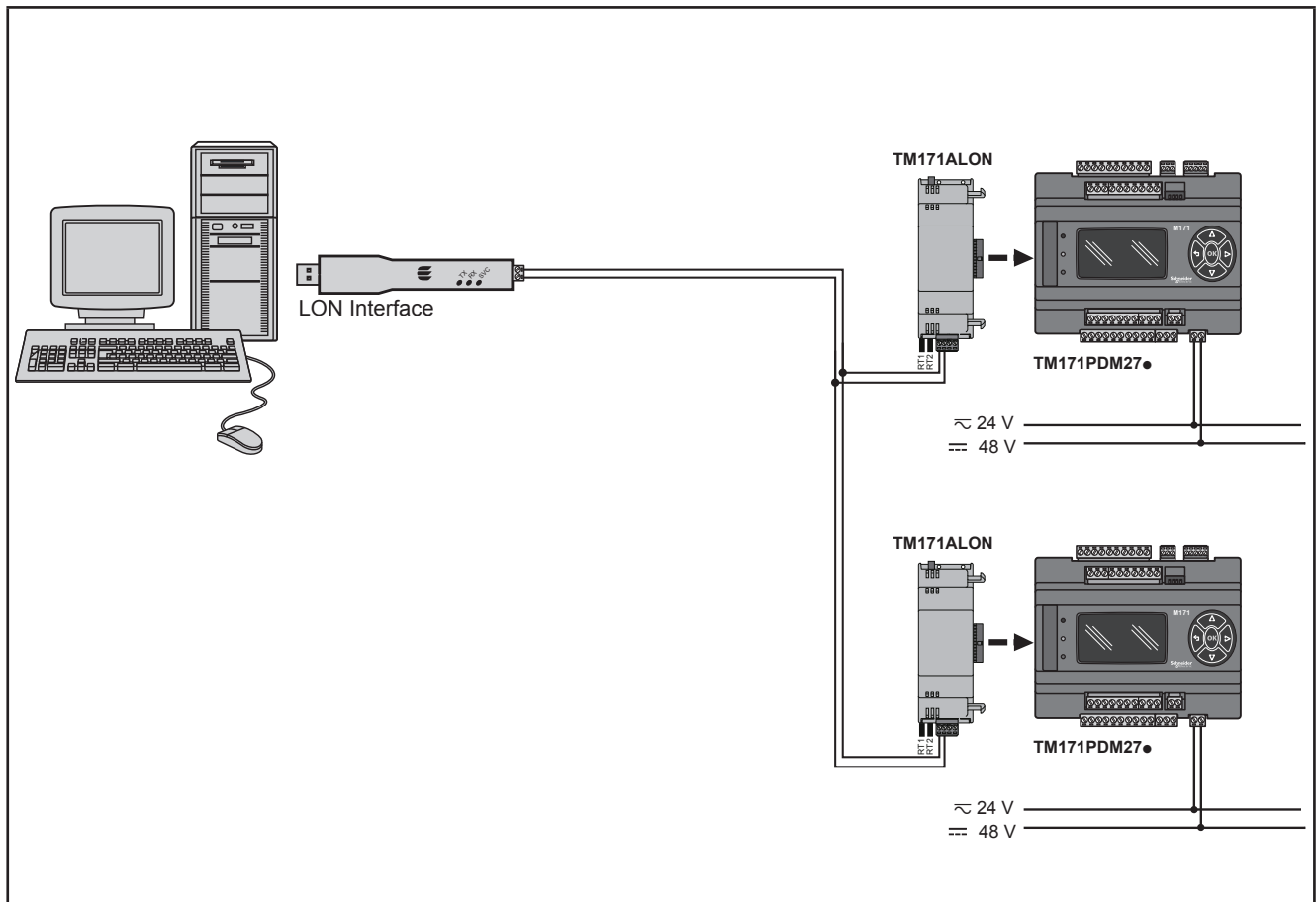

Fig. 50. LON protocol using TM171ALON

**NOTE:** The LonWorks communication module supports up to 63 nodes. Exceeding this specification may result in an electrical overload condition in the M171ALON Communication Module and consequently in the controller.

## **⚠ WARNING**

### **UNINTENDED EQUIPMENT OPERATION**

Do not exceed the maximum of 63 nodes on the TM171ALON Communication Module.

**Failure to follow these instructions can result in death, serious injury, or equipment damage.**

For more information on the LonWorks network, visit [www.echelon.com/technology/lonwork/](http://www.echelon.com/technology/lonwork/)

### 3.6. Ethernet connection (for M171 Performance Flush)

The **M171 Performance Flush** product is also designated for **WebVisu**

The Ethernet connection also allows communication using HTTP protocol, i.e. access to a Web Server contained in **M171 Performance**.

**EcoStruxure Machine Expert HVAC** allows the creation and management of web pages internally of **WebVisu (WEB SERVER HTTP)**, i.e. a website in miniature.

WEB functionalities allow local and remote access by way of an ordinary browser. Thanks to the web connection, the system provides reading, support and diagnostics services, as well as e-mail alarm alerts.

Main web functionalities:

- Web-based access.
- Remote reading and support.
- Local and remote system control, including alarms management.
- Preventive and predictive maintenance.
- Email alarm alerts.

Care must be taken and provisions made for use of this product as a control device to avoid inadvertent consequences of commanded machine operation, controller state changes, or alteration of data memory or machine operating parameters.

#### ⚠ WARNING

##### UNINTENDED EQUIPMENT OPERATION

- Configure and install the mechanism that enables the remote HMI local to the machine, so that local control over the machine can be maintained regardless of the remote commands sent to the application.
- You must have a complete understanding of the application and the machine before attempting to control the application remotely.
- Take the precautions necessary to assure that you are operating remotely on the intended machine by having clear, identifying documentation within the application and its remote connection.

**Failure to follow these instructions can result in death, serious injury, or equipment damage.**

Refer to the section on Parameters / ETHERNET PASSIVE PLUG-IN folder (see [CHAPTER 9 Parameters on page 103](#)).

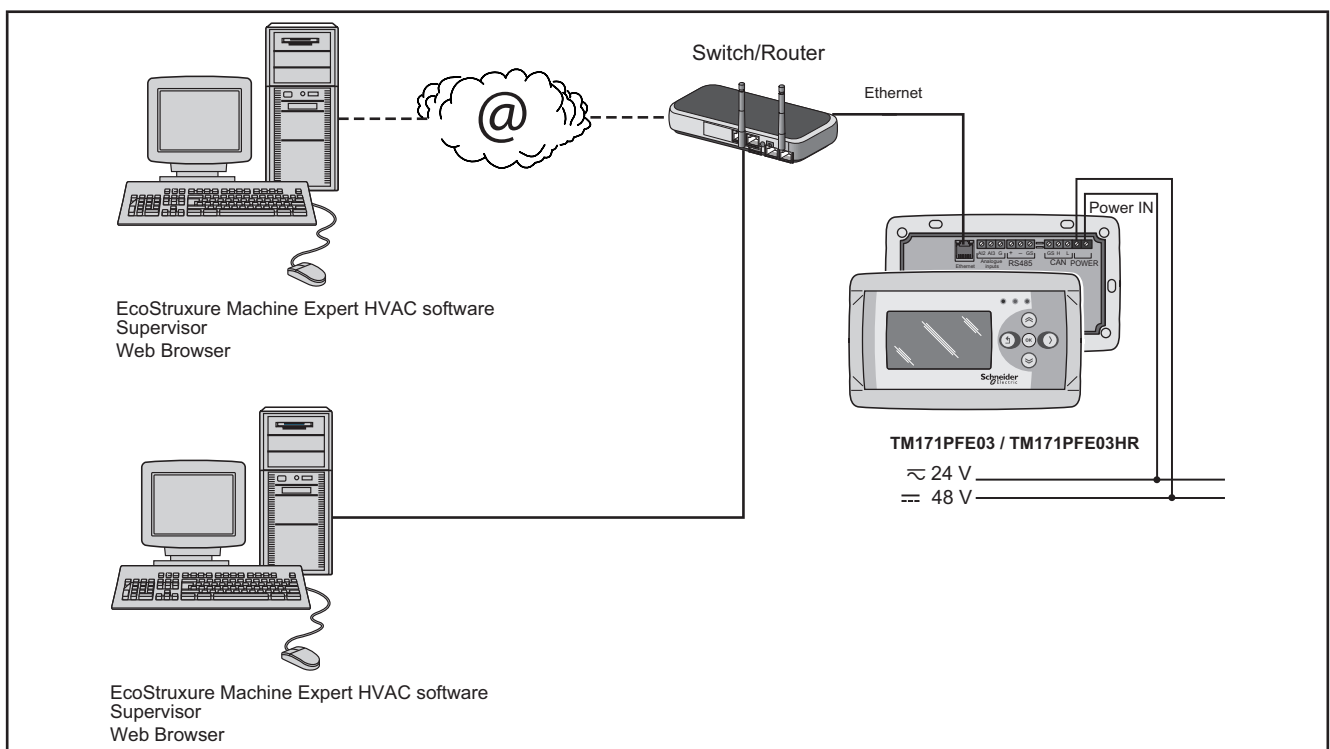

**Fig. 51.** WebVisu using M171 Performance Flush

## BRIDGE

**EcoStruxure Machine Expert HVAC** allows monitoring of the **Modicon M171O** or M171P controller or third party devices, typically Modbus/RTU slaves, where **WebVisu** (or **M171 Performance Flush** logic controller with Communication Module **TM171AETH**) is the Master Modbus/RTU.

In a **EcoStruxure Machine Expert HVAC** project, more exactly, **WebVisu** is used as a Modbus/TCP to Modbus/RTU protocol conversion element for Modbus 0x03 and 0x10 commands.

For example from **EcoStruxure Machine Expert HVAC**, set the connection with the **Modicon M171O** as Modbus/TCP, inserting the **WebVisu** IP address and the Modbus/RTU address of the **Modicon M171O** slave.

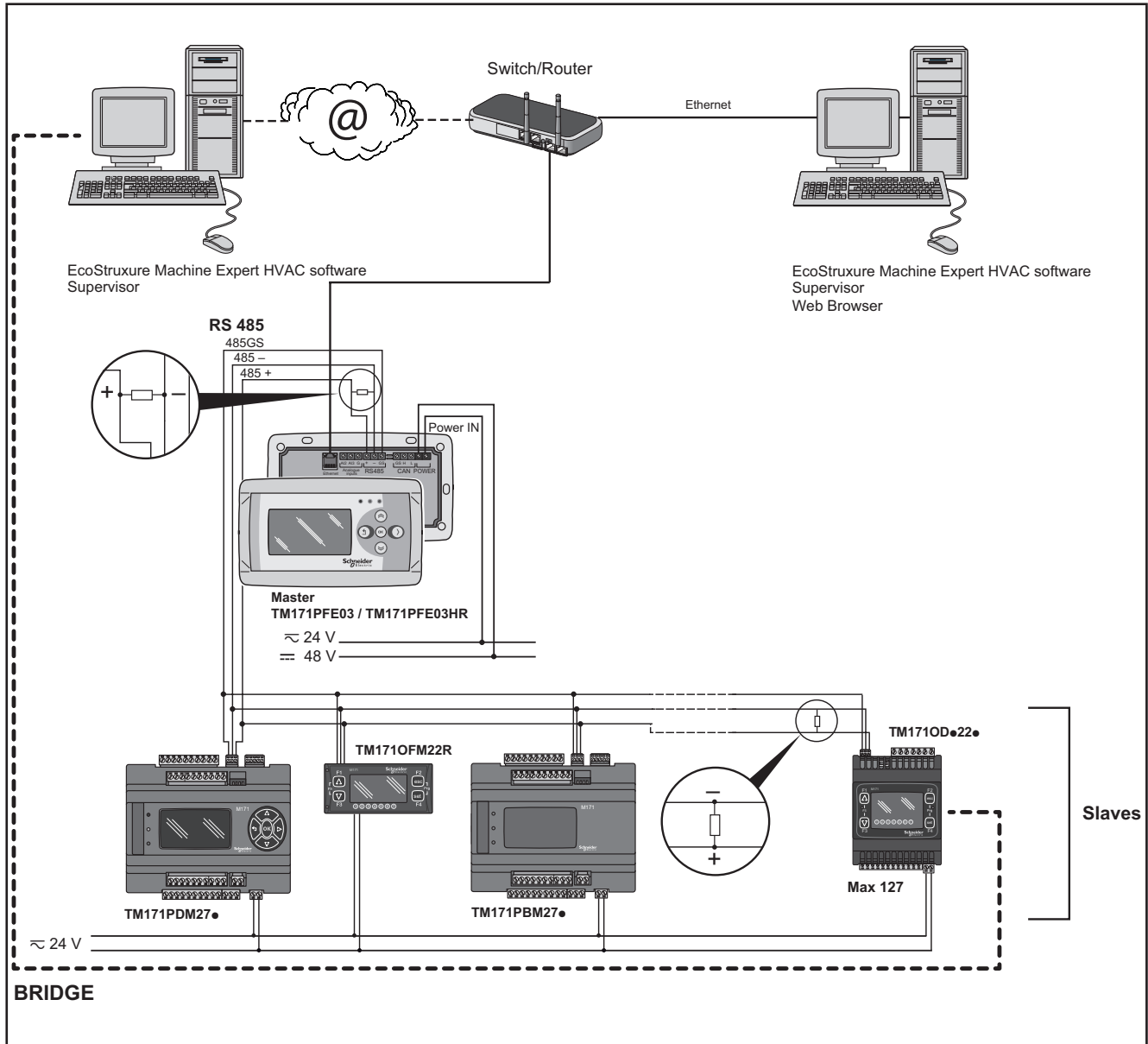

Fig. 52. WebVisu using M171 Performance Flush

## TFTP (Trivial File Transfer Protocol)

TFTP (Trivial File Transfer Protocol) can also be enabled for file transfer between PC and controller on an Ethernet network.

---

## CHAPTER 4

### Technical data

---

All **M171 Performance logic controllers** system components meet European Community (CE) requirements for open equipment. You must install them in an enclosure or other location designed for the specific environmental conditions and to minimize the possibility of unintended contact with hazardous voltages. Use metal enclosures to improve the electromagnetic immunity of your **M171 Performance logic controllers** system. This equipment meets CE requirements as indicated in the table below.

#### **WARNING**

##### **UNINTENDED EQUIPMENT OPERATION**

Do not exceed any of the rated values specified within this chapter.

**Failure to follow these instructions can result in death, serious injury, or equipment damage.**

Applying incorrect current or voltage levels on analog inputs and outputs could damage the electronic circuitry. Further, connecting a current input device to an analog input configured for voltage, and vice-versa, will likewise damage the electronic circuitry.

#### **NOTICE**

##### **INOPERABLE EQUIPMENT**

- Do not apply voltages above 11 Vdc to the analog inputs of the controller or Input/Output expansion module when analog input is configured as 0-10 V input.
- Do not apply current above 30 mA to the analog inputs of the controller or Input/Output expansion module when analog input is configured as 0-20 mA or 4-20 mA input.
- Do not mismatch applied signal with analog input configuration.

**Failure to follow these instructions can result in equipment damage.**

## 4.1. General specifications

### 4.1.1. M171 Performance 27 I/Os / TM171EP14R

The product complies with the following harmonized regulations:	EN 60730-2-9 / EN 60730-1
Construction of control	Electronic automatic Incorporated Control
Type of action	1.B relay output - 1.Y SSR output
Pollution degree	2
Over voltage category	II
Rated impulse voltage	2500 V
Power Supply	24 Vac, 50/60 Hz, or 24 Vdc, 48 Vdc Class 2 or SELV power source for all 27 I/O models 24 Vac, 50/60 Hz, or 24 Vdc Class 2 or SELV power source for TM171EP14R
Power Draw	22 VA / 18 W All 27 I/O models 16 VA / 7 W TM171EP14R
Digital outputs	<b>TM171EP14R:</b> SPST: DO2, DO3, DO4: 3 A resistive 240 Vac SPDT: DO1: 3 A resistive 240 Vac <b>TM171P•M27R/TM171EP27R:</b> SPST: DO3, DO4, DO5, DO6 : 3 A resistive 240 Vac SPDT: DO1, DO2 : 8 A resistive 240 Vac NO/NC - 1/2 HP 240 Vac NO <b>TM171P•M27S:</b> SPST: DO5, DO6 : 3 A resistive 240 Vac SPDT: DO1, DO2 : 8 A resistive 240 Vac NO/NC - 1/2 HP 240 Vac NO SSR: DO3, DO4 : 0,75 A resistive 240 Vac
Software class	A
Ambient operating conditions	-10 ... 55 °C (14 ... 131 °F) All 27 I/O models -10 ... 60 °C (14 ... 140 °F) TM171EP14R 10...90% RH (non condensing)
Transportation and storage conditions	-20...85 °C (-4...185 °F) 10...90% RH (non-condensing)
Environmental front panel rating	Open Type

### 4.1.2. M171 Flush

The product complies with the following harmonized regulations:	EN 60730-2-9 / EN 60730-1
Construction of control	Electronic automatic Incorporated Control
Type of action	1
Pollution degree	2
Over voltage category	I
Rated impulse voltage	330 V
Power Supply <sup>1</sup>	24 Vac, 50/60 Hz, or 24 Vdc, 48 Vdc Class 2 or SELV power source
Power Draw	5 W
Software class	A
Ambient operating conditions	-10 ... 55 °C (14 ... 131 °F) 10...90% RH (non condensante)
Transportation and storage conditions	-20...85 °C (-4...185 °F) 10...90% RH (non-condensing)
Environmental front panel rating	Type 1 enclosure

<sup>1</sup> For **M171 Performance Flush / M171 Performance Display Graphic** (TM171DGRP): powered by **M171 Performance TM171PDM27● / TM171PBM27R** or directly from an independent, properly rated power supply.

**NOTE:** When supplying power from the **M171 Performance logic controllers**, make the power connection cable as short as possible.

## ***NOTICE***

### **INOPERABLE EQUIPMENT**

Do not connect a power cable longer than 10m.

**Failure to follow these instructions can result in equipment damage.**

## 4.2. I/O features

### 4.2.1. M171 Performance I/O features

M171 Performance features for inputs and outputs.

Type and Label	No.	Description	TM171PDM27R TM171PBM27R TM171EP27R	TM171PDM27S
Digital input <b>DI1...DI8</b>	8	8 opto-isolated digital inputs Working voltage +24 Vac/dc $\pm 20\%$ or +48 Vdc $\pm 20\%$ Power draw max. 5 mA Digital inputs can be used as pulse counters. The length of the pulse (positive or negative) must be greater than 12 ms. See <b>CHAPTER 8 Physical I/O and ports configuration on page 88.</b>	✓	✓
Digital input <b>FAST DI</b>	1	1 no-voltage digital input (Pulse count + Read frequency) Note: measure a signal with a maximum frequency of 1 kHz See <b>CHAPTER 8 Physical I/O and ports configuration on page 88.</b>	✓	✓
Relay digital outputs High voltage <b>DO1, DO2</b>	7	2 x 8 A resistive 240 Vac relays NO/NC - 1/2 HP 240 Vac NO	✓	-
Relay digital outputs High voltage <b>DO3...DO7</b>		5 x 5 A resistive 240 Vac relays	✓	-
Relay digital outputs High voltage <b>DO1, DO2</b>	5	2 x 8 A resistive 240 Vac relays NO/NC - 1/2 HP 240 Vac NO	-	✓
Relay digital outputs High voltage <b>DO5, DO6, DO7</b>		3 x 5 A resistive 240 Vac relays	-	✓
SSR digital outputs High voltage <b>DO3, DO4</b>	2	2 x 0,75 A resistive 240 Vac SSR	-	✓
Analog outputs <b>AO1...AO5</b>	5	5 x 0-10 V / 4..20mA / ON-OFF configurable outputs: <ul style="list-style-type: none"> <li>• <b>0..10V</b> 2% full scale Min.load 500 <math>\Omega</math>; 1% full scale with load greater than 5 k<math>\Omega</math></li> <li>• <b>4...20mA</b> 2% full scale max. 400 <math>\Omega</math></li> <li>• <b>ON-OFF</b> Max.load 400 <math>\Omega</math></li> </ul> Note: AO4 and AO5 can be configured as Open Collector. See <b>CHAPTER 8 Physical I/O and ports configuration on page 88.</b>	✓	✓
Analog inputs <b>AI1 AI2 AI3 AI4 AI5 AI6</b>	6	See the following table	✓	✓

	NTC (NK103) 10 kΩ at 25 °C (77 °F) BETA value 3977	DI (1)	NTC (103AT-2) 10 kΩ at 25 °C (77 °F) BETA value 3435	4-20 mA	0-10 V
<b>AI1</b>	✓	✓	✓	-	-
<b>AI2</b>	✓	✓	✓	-	-
<b>AI3</b>	✓	✓	✓	✓	✓
<b>AI4</b>	✓	✓	✓	✓	✓
<b>AI5</b>	✓	✓	✓	✓	✓
<b>AI6</b>	✓	✓	✓	✓	✓
Range	-40...+150 °C (-40...+302 °F)	-	-50...+110 °C (-58...+230 °F)	0...1000	0...1000
Accuracy	0.5% full scale + 1 digit	-	0.5% full scale + 1 digit	1% full scale + 1 digit	1% full scale + 1 digit
Resolution	0.1 °C	-	0.1 °C	1 digit	1 digit
Input impedance	10 kΩ	20 kΩ	10 kΩ	100 Ω	21 kΩ

(1) DI Digital Input: voltage free digital input.

	0-5 V Ratiometric (1)	Pt1000	hΩ (NTC)	daΩ (Pt1000)
<b>AI1</b>	-	-	-	-
<b>AI2</b>	-	-	-	-
<b>AI3</b>	✓	✓	✓	✓
<b>AI4</b>	✓	✓	✓	✓
<b>AI5</b>	✓	✓	✓	✓
<b>AI6</b>	✓	✓	✓	✓
Range	0...1000	-200...+800 °C (-328...+1472 °F)	0...150 kΩ	0...30 kΩ
Accuracy	1% full scale + 1 digit	0.5% full scale + 1 digit	1% full scale + 1 digit	1% full scale + 1 digit
Resolution	1 digit	0.1 °C	1 hΩ	1 daΩ
Input impedance	21 kΩ	2 kΩ	10 kΩ	2 kΩ

(1) 0-5 V Ratiometric. 50 mA maximum current at 5 V

Also see [8.1.1. Analog inputs configuration for M171 Performance on page 89](#) for instructions on offsets and calibrations.

## 4.2.2. M171EP14R Performance I/O features

M171EP14R Performance features for inputs and outputs.

Type and Label	No.	Description	TM171EP14R
Digital input DI1...DI4	4	4 digital inputs NOT ISOLATED Working voltage 24 Vac/dc $\pm 10\%$ (Vac: max 38Vac) Power draw max. 5mA	✓
Relay digital outputs High voltage DO1...DO4	4	1 x 5A 250 Vac SPDT relay 3 x 3A 250 Vac SPST relays (common max 10A)	✓
Analog outputs AO1...AO2	2	2 x 0-10 V outputs: 4% full scale Min.load 5K $\Omega$ ; 2% full scale with load greater than 5K $\Omega$	✓
Analog inputs AI1 AI2 AI3 AI4	4	See the following table	✓

	NTC (NK103) 10 k $\Omega$ at 25 °C (77 °F) BETA value 3977	DI (1)	NTC (103AT-2) 10 k $\Omega$ at 25 °C (77 °F) BETA value 3435	4-20 mA	0-10 V
<b>AI1</b>	✓	✓	✓	✓	✓
<b>AI2</b>	✓	✓	✓	✓	✓
<b>AI3</b>	✓	✓	✓	✓	✓
<b>AI4</b>	✓	✓	✓	✓	✓
Range	-40...+137 °C (-40...+278.6 °F)	-	-50...+110 °C (-58...+230 °F)	0...1000	0...1000
Accuracy	0.5% full scale + 1 digit	-	0.5% full scale + 1 digit	1% full scale + 1 digit	1% full scale + 1 digit
Resolution	0.1 °C	-	0.1 °C	1 digit	1 digit
Input impedance	10 k $\Omega$	10 k $\Omega$	10 k $\Omega$	<200 $\Omega$	>10 k $\Omega$

(1) DI Input: voltage free digital input.

	0-5 V (1)	Pt1000	h $\Omega$ (NTC)	da $\Omega$ (Pt1000)	PTC (KTY81)
<b>AI1</b>	✓	✓	✓	✓	✓
<b>AI2</b>	✓	✓	✓	✓	✓
<b>AI3</b>	✓	✓	✓	✓	✓
<b>AI4</b>	✓	✓	✓	✓	✓
Range	0...1000	-200...+295 °C (-328...+563 °F)	0..150 k $\Omega$	0...30 k $\Omega$	-50°C ..+150 °C (-58...+302 °F)
Accuracy	1% full scale + 1 digit	0.5% full scale + 1 digit	1% full scale + 1 digit	1% full scale + 1 digit	0.5% full scale + 1 digit
Resolution	1 digit	0.1 °C	1 h $\Omega$	1 da $\Omega$	0.1 °C
Input impedance	>20 k $\Omega$	2 k $\Omega$	10 k $\Omega$	2 k $\Omega$	2 k $\Omega$

(1) Ratiometric. 50 mA maximum current at 5 V

Also see [8.1.1. Analog inputs configuration for M171 Performance on page 89](#) for instructions on offsets and calibrations.

### 4.2.3. M171 Performance Flush I/O features

M171 Performance Flush features for inputs.

Type and Label	Probe	Description	Resolution	Accuracy	Measurement range	Impedance	TM171PFE03	TM171PFE03HR
Analog inputs								
<b>AI1</b>	On-board	NTC	0.1 °C / °F	0.5% full scale + 1 digit	-	10 kΩ	✓	✓
<b>AI2</b> configurable	Remote	NTC 103AT	0.1 °C / °F	0.5% full scale + 1 digit	-50...+110 °C (-58...230 °F)	10 kΩ		
	NOT included	NTC NK103	0.1 °C / °F	0.5% full scale + 1 digit	-40...+150 °C (-40...302 °F)	10 kΩ	✓	✓
		D.I.(1)	-	-	-	20 kΩ		
<b>AI3</b> configurable	Remote	4...20 mA	1 digit	1% full scale + 1 digit	0...1000	100 Ω	✓	-
	NOT included	0-5 V (2)	1 digit	1% full scale + 1 digit	0...1000	21 kΩ	-	-
		0..10 V	1 digit	1% full scale + 1 digit	0...1000	21 kΩ	-	-
<b>AI4</b>	On-board	On-board %RH input	0.01 %RH (0%=0pt, 100% = 1000pt)	±3% [20...80%] ±5% ...elsewhere	0-100 %RH	-	-	✓

(1) D.I. Digital Input voltage-free.

(2) 50 mA maximum current at 5 V.

Also see [8.1.2. Analog inputs configuration for M171EP14R on page 90](#) for instructions on offsets and calibrations.

### 4.3. Display

M171 Performance TM171PDM27● references, remote display and M171 Performance Flush:

- backlit with LEDs
- 3 LEDs

LEDs and backlighting can be controlled from application.

#### 4.3.1. M171 Performance Display Graphic / M171 Performance Flush display

<b>Display</b>	Monochromatic LCD graphic display 128x64px backlit with LEDs
<b>Container</b>	Backplate + frame in PC+ABS UL94 V-0 plastic resin, transparent polycarbonate front cover, polyester membrane keypad

### 4.4. Serials

Serial	Description	Notes	References
CAN	CAN Expansion Bus	max 50 m at 500 kpbs; 200 m at 125 kpbs.	<b>TM171P●●●●</b> <b>TM171EP●●R</b> <b>M171 Performance Display Graphic (TM171DGRP)</b>
		If necessary, apply a 120 Ω termination resistor to both the ends.	
RS 485	2 x RS 485 serial	If the controller is connected at the end of the RS 485 communication line, apply a 120 Ω termination resistor between line + and line - of the RS 485	<b>TM171P●●●●</b> <b>TM171EP27R</b>
		Only one RS 485 serial port can be configured as Modbus master at the same time.	
USB	1 Type A USB female connector (Host)	'Mass Storage' profile External memory, <b>FAT32</b> formatting.	<b>TM171P●●●●</b>
	1 Type mini-B USB female connector (Device)	Connection between PC and device through USB standard CDC profile.	
ETHERNET	Modbus TCP ETHERNET port	Equipment includes MACADDRESS, in barcode and 12-digit alphanumeric format.	<b>M171 Performance Flush</b>

Pay special attention when connecting serial lines. Miswiring may lead to inoperable equipment.

<b>NOTICE</b>
<b>INOPERABLE EQUIPMENT</b> <ul style="list-style-type: none"> <li>• Do not connect equipments that communicate using RS 485 serial to CAN Expansion Bus terminals.</li> <li>• Do not connect equipments that communicate using CAN Expansion Bus to RS 485 terminals.</li> </ul> <b>Failure to follow these instructions can result in equipment damage.</b>

#### 4.4.1. TM171A●●●● Communication Module

	Serial	Notes	Terminals
<b>TM171ARS232</b>	RS232 Nullmodem	Digital outputs 1 x SPDT 5 A 250 Vac relay	terminals 1...3 screw type removable, spacing 5, 90° insertion for cables with 2.5 mm <sup>2</sup> cross-section. + DB9 connector
<b>TM171ACAN</b>	Double serial port	Opto-isolated CAN serial	removable screw type , spacing 3.81, 90° insertion for cables with 2.5 mm <sup>2</sup> cross-section.
<b>TM171AMB TM171ARS485</b>	Double serial port	Opto-isolated RS485 serial	removable screw type , spacing 3.81, 90° insertion for cables with 2.5 mm <sup>2</sup> cross-section.
<b>TM171AETH</b>	Modbus TCP ETHERNET port	-	RJ45 connector
<b>TM171AETHRS485</b>	Modbus TCP ETHERNET port Double serial port	Opto-isolated RS485 serial	RJ45 connector removable screw type , spacing 3.81, 90° insertion for cables with 2.5 mm <sup>2</sup> cross-section.
<b>TM171ALON</b>	LON	-	-
<b>TM171APBUS</b>	Profibus DP Slave-V0	-	-

## 4.5. Power supply

The **M171 Performance logic controllers** and associated devices require power supplies with a nominal voltage of 24 Vac / 24 Vdc or 48 Vdc. The power supplies/transformers must be rated Safety Extra Low Voltage (SELV) according to IEC 61140. These sources of power are isolated between the electrical input and output circuits of the power supply as well as simple separation from ground (earth), PELV and other SELV systems.

### **DANGER**

#### **GROUND LOOP CAUSING ELECTRIC SHOCK AND/OR INOPERABLE EQUIPMENT**

- Do not connect the 0 V power supply/transformer connection supplying this equipment to any external ground (earth) connection.
- Do not connect any 0 V or ground (earth) of the sensors and actuators connected to this equipment to any external ground connection.
- If necessary, use separate power supplies/transformers to power sensors or actuators isolated from this equipment.

**Failure to follow these instructions will result in death or serious injury.**

If the specified voltage range is not maintained, or the effective separation of the SELV circuit connected to the concerned equipment is compromised, the products may not function as intended or may become damaged and inoperable.

### **WARNING**

#### **POTENTIAL OF OVERHEATING AND FIRE**

- Do not connect the equipment directly to line voltage.
- Use only isolating SELV power supplies/transformers to supply power to this equipment.

**Failure to follow these instructions can result in death, serious injury, or equipment damage.**

The equipment must be connected to a suitable power supply/transformers with the following features:

Primary voltage	Depending on requirements of the individual device and/or country of installation.
Secondary voltage	+24 Vac/dc $\pm 20\%$ or +48 Vdc $\pm 20\%$
Power supply frequency Vac	50/60 Hz
Power	minimum 18 W ( <b>M171 Performance</b> ) minimum 5 W ( <b>M171 Performance Flush</b> )

## 4.6. Mechanical dimensions

	Length (L) <u>mm</u> in	Depth (d) <u>mm</u> in	Height (H) <u>mm</u> in	Notes
<b>M171 Performance</b> TM171PDM27● / TM171PBM27R / TM171EP27R	<u>140</u> 5.51	<u>61.6</u> 2.42	<u>110</u> 4.33	-
<b>M171 Performance TM171EP14R</b>	<u>70</u> 2.75	<u>61.6</u> 2.42	<u>87</u> 3.42	-
<b>TM171A●●●● Communication Module</b>	<u>35</u> 1.38	<u>61.6</u> 2.42	<u>110</u> 4.33	-
<b>M171 Performance Display Graphic (TM171DGRP)</b> <b>M171 Performance Flush</b>	<u>160</u> 6.3	<u>10</u> 0.39	<u>96</u> 3.8	-
<b>Opening for panel-mounting of M171 Performance</b> <b>Display Graphic (TM171DGRP) or M171</b> <b>Performance Flush</b>	<u>138</u> 5.43	-	<u>68</u> 2.68	(+0.2mm / -0.1mm)

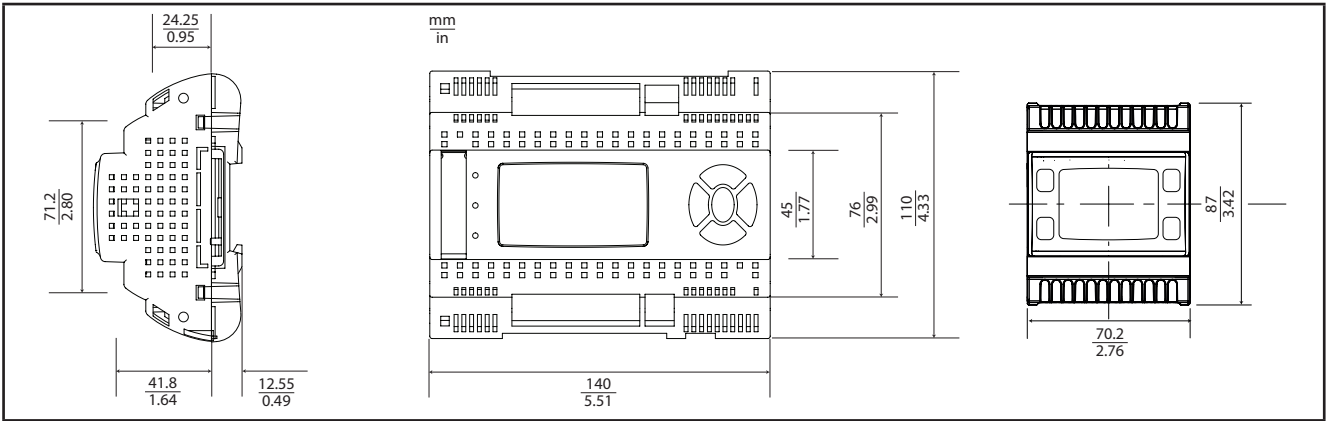

**Fig. 53.** TM171PDM27● / TM171PBM27R / TM171EP27R / TM171EP14R

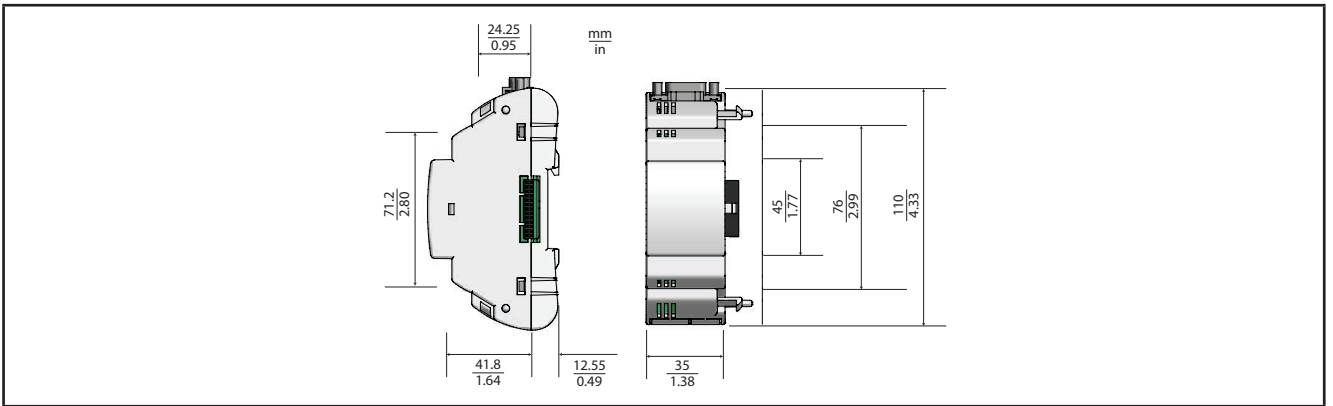

**Fig. 54.** TM171A●●●

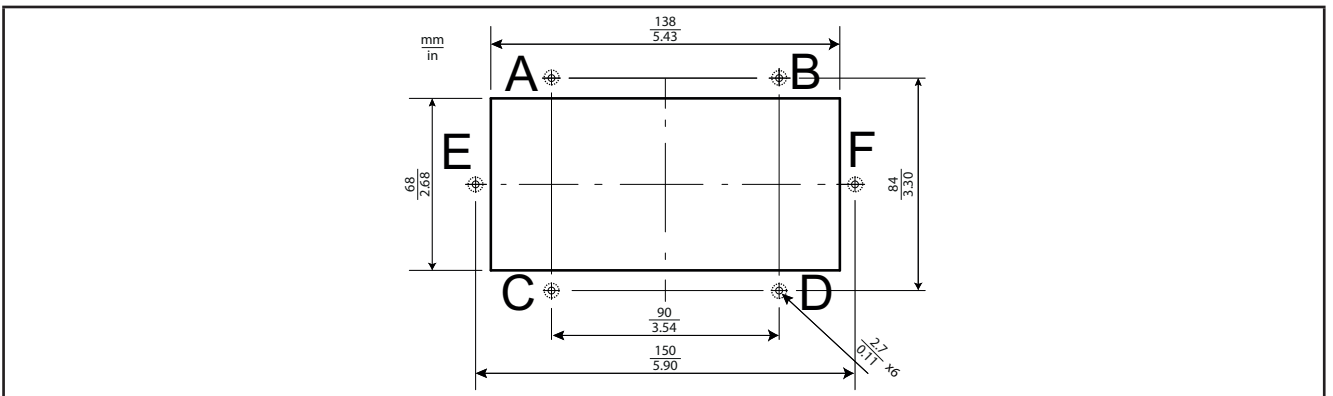

**Fig. 55.** Panel opening dimensions for M171 Performance Display Graphic (TM171DGRP) or M171 Performance Flush

## CHAPTER 5

### M171 Performance User Interface

The interface, comprising the front cover of the controller, allows you to perform operations to use the device.

#### 5.1. Keys and LEDs

The data provided for keys refers to **TM171PDM27●** references.

The **TM171PBM27R** module has no display. Use the **M171 Performance Display Graphic (TM171DGRP)** to work on this controller.

The **TM171EP●●R** expansion module has no display.

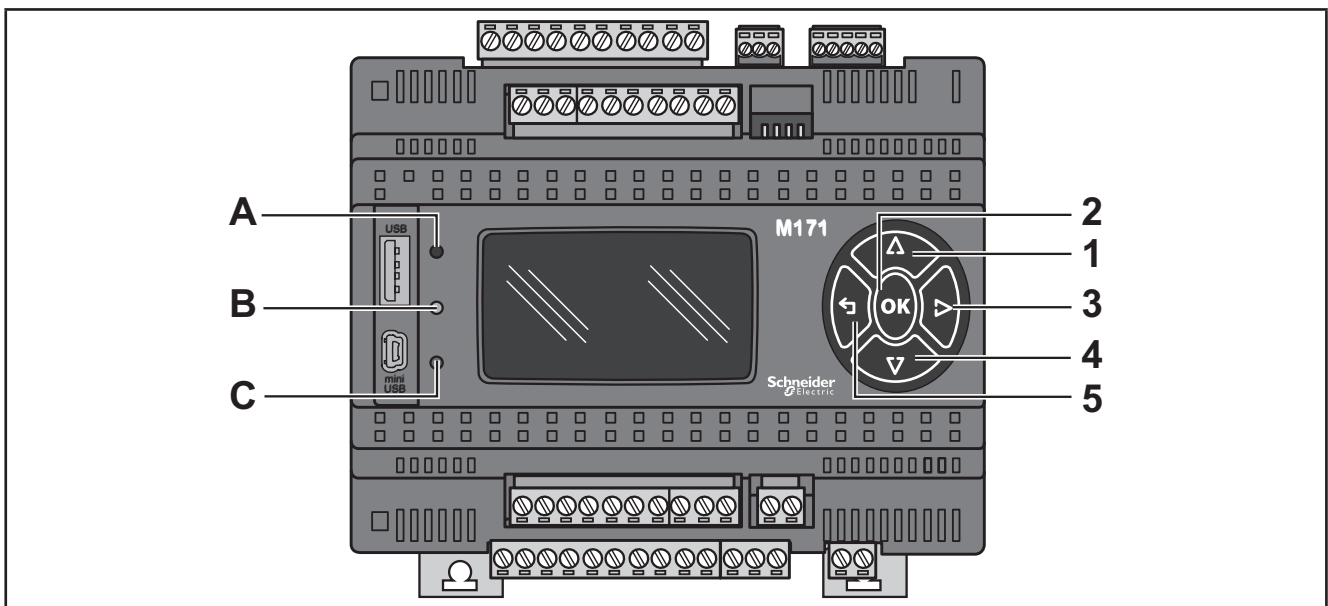

Fig. 56. TM171PDM27●

The keys can be programmed from the controller application. By default, the device displays a short menu containing the following default settings.

No.	Key	Press once (press and release)
1	△ UP	<ul style="list-style-type: none"> <li>• Scroll up</li> <li>• Increase/modify a value</li> <li>• Go to next label</li> </ul>
2	OK	<ul style="list-style-type: none"> <li>• Scroll down</li> <li>• Move to next level/menu (open folder, subfolder, parameter, value)</li> <li>• Enter/exit Edit mode</li> <li>• Confirm operation</li> </ul>
3	RIGHT ▷	<ul style="list-style-type: none"> <li>• Move cursor to right in Edit Mode</li> </ul>
4	DOWN ▽	<ul style="list-style-type: none"> <li>• Scroll down</li> <li>• Decrease/modify a value</li> <li>• Go to previous label</li> </ul>
5	↶ Exit	<ul style="list-style-type: none"> <li>• Exit menu page / go back to previous menu</li> <li>• Move cursor to left in Edit Mode</li> <li>• (press and hold) Exit Edit Mode without saving</li> </ul>

The LEDs can be programmed from the application.

By default, they are used for USB management - see the relative section on USB-Handling (see [3.1.6. Serial connections on page 28](#)).

LEDs	Description
A B C	A, B and C LEDs are programmable via controller application

## 5.2. First power on

When the equipment is powered on for the first time, a few summary pages are displayed showing system status (**SYSTEM INFO**).

SYSTEM INFO
HW
BIOS
DATE
BOOT
EEPROM

NOR FLASH	OK
NAND FLASH	OK
SDRAM	OK
BATRAM	OK
RTC	OK
Plug-in	None
USB-H	OK
USB-D	Service area

## CHAPTER 6

### M171 Performance Display Graphic user interface

The interface, comprising the front cover of the controller, allows you to perform operations to use the device.

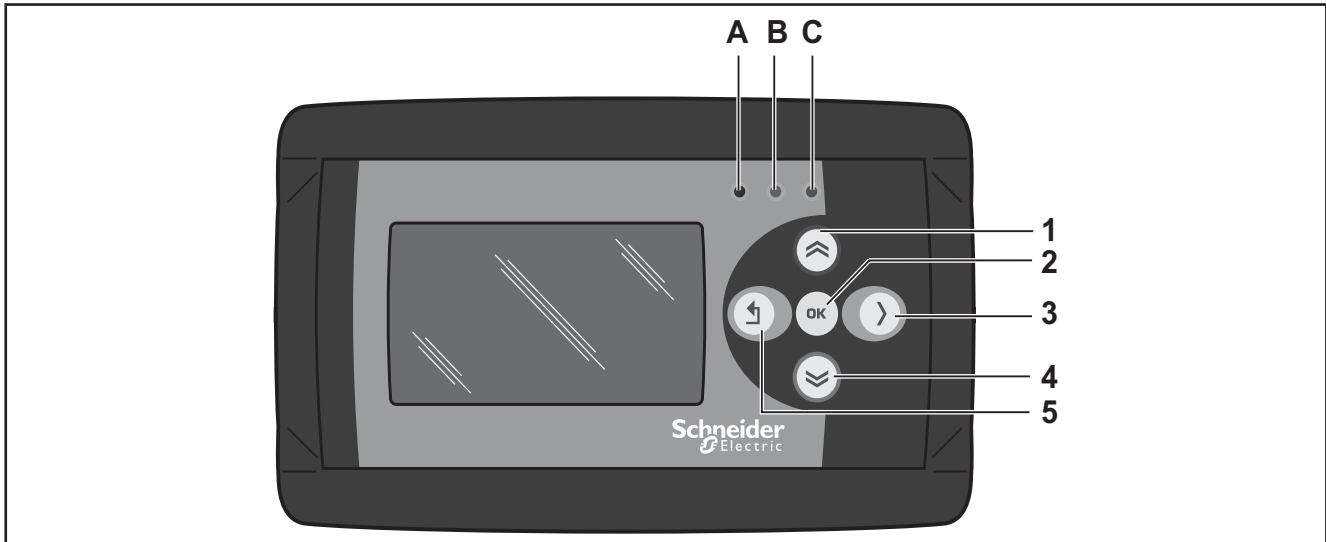

Fig. 57. M171 Performance Display Graphic (TM171DGRP)

#### 6.1. Keys and LEDs

The keys can be programmed from the controller application. By default, the device displays a short menu containing the following default settings.

No.	Key	Press once (press and release)
1	UP ⤴	<ul style="list-style-type: none"><li>• Scroll up</li><li>• Return to previous page (for example 1/3 ←2/3)</li><li>• Increase / modify a value</li><li>• Go to next label</li></ul>
2	OK	<ul style="list-style-type: none"><li>• Scroll down</li><li>• Move to next level/menu (open folder, subfolder, parameter, value)</li><li>• Enter/exit Edit mode</li><li>• Confirm operation</li></ul>
3	RIGHT >	<ul style="list-style-type: none"><li>• Move cursor to right in Edit Mode</li></ul>
4	DOWN ⤵	<ul style="list-style-type: none"><li>• Scroll down</li><li>• Move to the next page (for example 1/3→2/3)</li><li>• Decrease / modify a value</li><li>• Go to previous label</li></ul>
5	Exit ⏪	<ul style="list-style-type: none"><li>• Exit menu page / go back to previous menu</li><li>• Move cursor to left in Edit Mode</li><li>• (press and hold) Exit Edit Mode without saving</li></ul>

## DIAGNOSTICS Menu

**M171 Performance Display Graphic** (TM171DGRP) is factory-configured with a default DIAGNOSTICS (DIA) menu that appears when the equipment is powered on.

After uploading a controller application and/or a HMI menu from **EcoStruxure Machine Expert HVAC**, the main display consists of the application menu created with **EcoStruxure Machine Expert HVAC** Interface.

In which case, to open the DIAGNOSTICS menu proceed as follows:

No.	Key combination	Press and hold for about 3 seconds
4+5	DOWN	Open DIAGNOSTICS menu
	↵ Exit	

To return to the controller application menu, open the “HMI Management” page, select ↵ and press the **OK** key.

See [6.4. Remote interface on page 80](#).

The LEDs can be programmed from the controller application.

LEDs	Description
A B C	A, B and C LEDs are programmable via controller application

## 6.2. First power on

When the equipment is powered on for the first time, a few summary pages are displayed showing system status (**SYSTEM INFO**).

SYSTEM INFO
HW
BIOS
DATE
BOOT
EEPROM

NOR FLASH	OK
SDRAM	OK

The system will also search for the controller application and the local menu...

If present, the menu will appear on the display.

HMI searching	...
DIA	

## 6.3. DIAGNOSTICS menu

The default DIAGNOSTICS menu of the **M171 Performance Display Graphic** (TM171DGRP) allows you to manage system parameters (BIOS parameters) and the interface (HMI).

The DIAGNOSTICS menu can be displayed in 5 languages: English, Italian, German, Spanish and French.

To change the default language, open BIOS Parameters > Display.

M171 Display Graphic
BIOS parameters
HMI Management

### 6.3.1. BIOS parameters

Parameter configuration menu. See [CHAPTER 9 Parameters on page 103](#).

This menu is depopulated with respect to the parameters table contained in the corresponding chapter and in the **EcoStruxure Machine Expert HVAC** device.

A language change example:

BIOS parameters → < **OK** key > Display 1/3 → < **OK** key > Edit Mode < **UP/DOWN** key > select language < **OK** key > < ← key >



See parameter Display/Hmi\_Language.

### 6.3.2. HMI Management

See [6.4. Remote interface on page 80](#).

## 6.4. Remote interface

M171 Display Graphic
Language: 0    ⬆️⬇️⬆️
HMI Management

### 6.4.1. Language

This section is for setting the language of the remote menu, defined from the **EcoStruxure Machine Expert HVAC** User Interface.

The number of languages and the order are established by the corresponding application/menu.

See parameter HMI Management/Hmi\_Language (see [CHAPTER 9 Parameters on page 103](#)).

### 6.4.2. ⬆️⬇️⬆️

To return to the menu of the controller application, move the cursor onto the ⬆️⬇️⬆️ symbol and press the **OK** key.

### 6.4.3. HMI Management

This page shows the configuration of the remote page.

M171 Display Graphic	
File: HMIREM.KBD	↑↓
Id: 0	☐↑
Com: CAN	
Addr: 124	

From these pages it is possible to “launch” (run) the corresponding menu – if present.

Move the cursor to ↑↓ and press the **OK** key.

To “upload” a remote page use ☐↑

After selecting the desired menu move the cursor to ↑↓ to view the menu.

Upload remote page	
Upload page?	
The process cannot be interrupted	
Cancel	OK

Press **OK** to upload or any other key to cancel:

Upload remote page	
Uploading...	
■ ■ ■ ■ ■ ■ ■ ■ □ □	
80%	

The upload may take up to a minute.

If there are no data to upload, the following screen displays:

Upload remote page	
There are no remote pages on the card.	
Press OK	

## CHAPTER 7

### M171 Performance Flush user interface

The interface, comprising the front cover of the controller, allows you to perform operations to use the device.

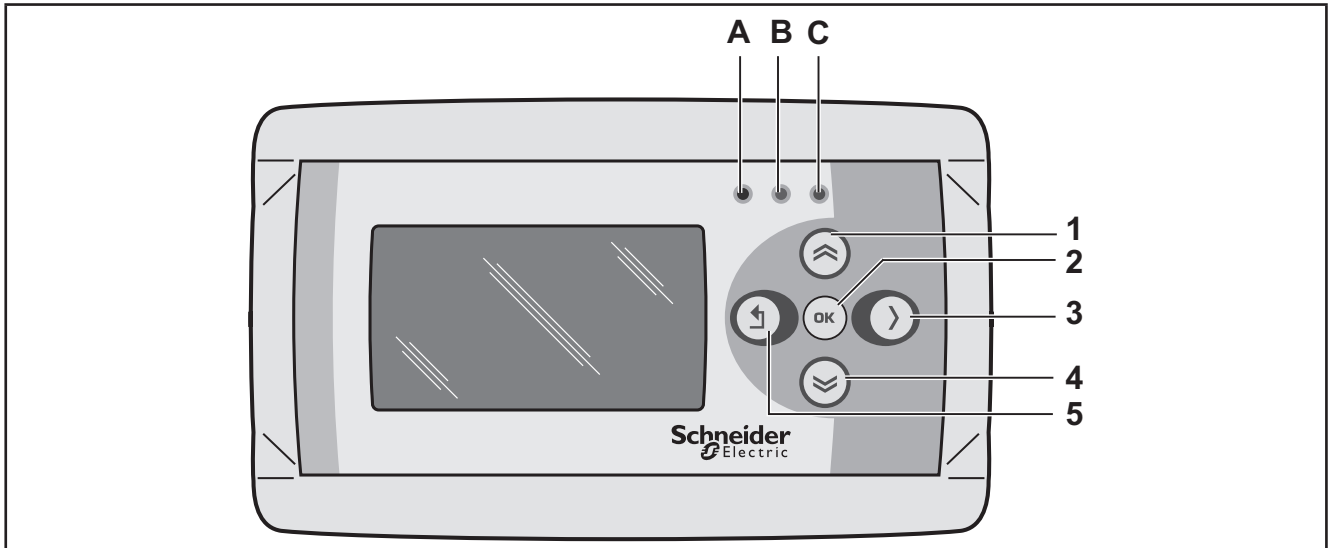

Fig. 58. M171 Performance Flush

The keys can be programmed from the controller application. By default, the device displays a short menu containing the following default settings.

#### 7.1. Keys and LEDs

No.	Key	Press once (press and release)
1	 UP	<ul style="list-style-type: none"><li>• Scroll up</li><li>• Return to previous page (for example 2/10 ← 3/10)</li><li>• Increase / modify a value</li><li>• Go to the next label</li></ul>
2	OK	<ul style="list-style-type: none"><li>• Scroll down</li><li>• Move to next level/menu (open folder, subfolder, parameter value)</li><li>• Enter/exit Edit mode</li><li>• Confirm operation</li></ul>
3	RIGHT >	<ul style="list-style-type: none"><li>• Moves cursor to right in Edit Mode</li></ul>
4	DOWN 	<ul style="list-style-type: none"><li>• Scroll down</li><li>• Move to the next page (for example 1/10 → 2/10)</li><li>• Decrease / modify a value</li><li>• Go to previous label</li></ul>
5	 Exit	<ul style="list-style-type: none"><li>• Exit menu page / go back to previous menu</li><li>• Move cursor to left in Edit Mode</li><li>• (press and hold) Exit Edit Mode without saving any changes</li></ul>

The **M171 Performance Flush** is factory-configured with a default DIAGNOSTICS (DIA) menu that appears when the equipment is powered on.

After uploading of a controller application and/or a HMI menu from **EcoStruxure Machine Expert HVAC**, the main display consists of the application menu created with **EcoStruxure Machine Expert HVAC** Interface.

In which case, to open the DIAGNOSTICS menu proceed as follows:

Key combination		Press and hold for about 3 seconds
4+5	DOWN	Open DIAGNOSTICS menu
	↶ Exit	

The LEDs can be programmed from the controller application.

LEDs	Description
A B C	A, B and C LEDs are programmable via controller application

To return to the controller application menu open the 'HMI Management' page ([7.3.2. HMI management on page 84](#)), select ↵ and press the **OK** key.

See [7.4. Remote interface on page 86](#).

## 7.2. First power on

When the equipment is powered up for the first time, a few summary pages are displayed showing system status (**SYSTEM INFO**).

SYSTEM INFO
HW
BIOS
DATE
BOOT
EEPROM

NOR FLASH	OK
NAND FLASH	OK
SDRAM	OK
BATRAM	OK
RTC	OK

The system will also search for the controller application and the local menu...  
If present, the menu will appear on the display

PLC searching	...
HMI searching	...
CON	loaded

### 7.3. DIAGNOSTIC menu

The DIAGNOSTICS menu of the **M171 Performance Flush** is used to manage system parameters (BIOS parameters), remote interfaces (HMI) and to display I/O values and clock.

The DIAGNOSTICS menu can be displayed in 5 languages: English, Italian, German, Spanish and French.

To change the language, open BIOS Parameters > Display

M171 Performance Flush
BIOS parameters
HMI Management
Probe values
Date and time

#### 7.3.1. BIOS parameters

For Parameter configuration menu, see **CHAPTER 9 Parameters on page 103**.

This menu is depopulated with respect to the parameters table contained in the corresponding chapter and in the **EcoStruxure Machine Expert HVAC** device.

A language change example:

BIOS parameters → < **OK** key > Display 1/3 → < **OK** key > Edit Mode < **UP/DOWN** key > select language < **OK** key > < ← key >



See parameter Display/Hmi\_Language.

#### 7.3.2. HMI management

See **7.4. Remote interface on page 86**.

#### 7.3.3. Probe values

Shows input values (read only).

**M171 Performance Flush** has 3 inputs.

A **TM171PFE03HR** example:

Probes values 1/3
Internal NTC
27.3
°C, °F

Probes values 2/3
External NTC
-----
°C, °F

Probes values 3/3
Humidity sensor
43.38
RH%

For offset programming see **8.1.2. Analog inputs configuration for M171EP14R on page 90**.

---

### 7.3.4. Date and time

Shows time (HH : MM : SS) and date (DD / MM / YY) of the internal clock.

Date and time
14 : 45 : 45 20 / 07 / 11
Update

To edit the value press **OK**. Select the value that you want to modify.  
Press the **OK** key to enter Edit Mode. Use the **UP** and **DOWN** keys to modify value. Confirm with the **OK** key.  
Select 'Update' and press **OK** to update the clock.

Date and time
16 : 50 : 56 20 / 07 / 11
Update

## 7.4. Remote interface

M171 Performance Flush	
Language: 0	↑↓
HMI sel: Network	
COM setting	
HMI Management	

### 7.4.1. Language

This section is for setting the language of the remote menu, defined from the **EcoStruxure Machine Expert HVAC User Interface**.

The number of languages and the order are established by the corresponding application/menu.  
See parameter HMI Management/**Hmi\_Language**.

### 7.4.2. ↑↓

To return to the menu of the controller application, move the cursor onto the ↑↓ symbol and press the **OK** key.  
See **7.4.3. HMI sel on page 86**.

### 7.4.3. HMI sel

This section is for setting the menu to be shown on the display.  
By default HMI menus are NOT present (only the DIAGNOSTICS menu is available).

**Network:** this is the **M171 Performance Flush** 'local' menu (local HMI).

**rem1...rem10:** menus located on max 10 **M171 Performance** devices connected to the network that can be 'uploaded' to **M171 Performance Flush**.

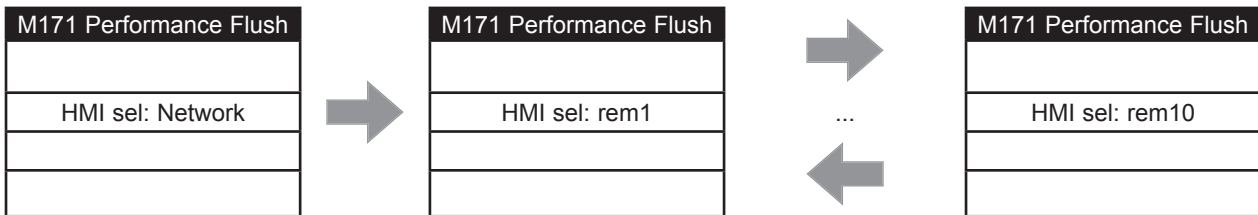

To move from one page to the next press the **UP** and **DOWN** keys.  
After selecting the desired menu move the cursor onto ↑↓ to view the menu

Launch remote page
Please Wait

If OK the display will show the selected menu (controller application).  
If the menu is not present, the following screen appears

Warning
Upload failed
Press OK

## 7.4.4. COM Setting

This **read-only** page shows the configuration of the **M171 Performance Flush** serial ports.

M171 Performance Flush
CAN : 1 . 500000
485s : 1 . 38400.P81
ETH : 010.000.000.100

## 7.4.5. HMI Management

This page shows the configuration of the 10 remote pages.

M171 Performance Flush 1/10	M171 Performance Flush 1/10	...	M171 Performance Flush 10/10
File: HMIREM.KBD			
Id: 0	Id: 0		Id: 0
Com: CAN	Com: CAN		Com: CAN
Addr: 125	Addr: 000		Addr: 000

From these pages it is possible to 'launch' (run) the corresponding menu – if present  
Move the cursor onto  $\uparrow\downarrow$  and press the **OK** key.

It will not be possible to launch the local (network) menu from this section.  
In the example only one remote page is present.

To 'upload' a remote page use  $\square\uparrow$ .

After selecting the desired menu move the cursor onto  $\uparrow\downarrow$  to view the menu.

Upload remote page
Upload page?
The process cannot be interrupted
Cancel                      OK

Press **OK** to upload or any other key to cancel

Upload remote page
Uploading...
■■■■■■■■■■□□
80%

The upload may take up to a minute.

If there are no data to upload, the following screen displays

Warning
There are no remote pages on the card
Press OK

## CHAPTER 8

### Physical I/O and ports configuration

From time to time, new input modules, output modules or other devices are made available that are not documented in the following information. For information on new devices, contact your local Schneider Electric representative.

#### NOTICE

##### INOPERABLE EQUIPMENT

Update the controller firmware to the latest version every time you install a newly released Input/Output expansion module or other device to this equipment.

**Failure to follow these instructions can result in equipment damage.**

**NOTE:** For more information on how to update the controller firmware, contact your local Schneider Electric representative.

	M171 Performance	M171 Performance Flush
Analog inputs	Configurable by parameter (see <a href="#">8.1.1. Analog inputs configuration for M171 Performance on page 89</a> )	Configurable by parameter (see <a href="#">8.1.2. Analog inputs configuration for M171EP14R on page 90</a> )
Analog outputs	Configurable by parameter (see <a href="#">"8.2. Analog outputs configuration for M171 Performance"</a> )	-
Digital inputs	Configurable by parameter (see <a href="#">8.3. Digital inputs configuration for M171 Performance on page 93</a> )	-
Digital outputs	Configurable by parameter (see <a href="#">8.4. Digital outputs configuration for M171 Performance on page 94</a> )	-
Serials	Configurable by parameter (see <a href="#">9.1.1. TM171PDM27• / TM171PBM27R / TM171EP27R parameters on page 104</a> ) or dip-switch (see <a href="#">on page 94</a> )	Configurable by parameter (see <a href="#">9.1.2. M171EP14R parameters on page 115</a> )

Applying incorrect current or voltage levels on analog inputs and outputs could damage the electronic circuitry. Further, connecting a current input device to an analog input configure for voltage, and vice-versa, will likewise damage the electronic circuitry.

#### NOTICE

##### INOPERABLE EQUIPMENT

- Do not apply voltages above 11 Vdc to the analog inputs of the controller or Input/Output expansion module when analog input is configured as 0-10V input.
- Do not apply current above 30 mA to the analog inputs of the controller or Input/Output expansion module when analog input is configured as 0-20 mA or 4-20 mA input.
- Do not mismatch applied signal with analog input configuration.

**Failure to follow these instructions can result in equipment damage.**

## 8.1. Analog inputs

M171 Performance and M171 Performance Flush have analog inputs.

### 8.1.1. Analog inputs configuration for M171 Performance

There are a total of 6 analog inputs, referred to below as AI1...AI6.

Using the parameters, a physical resource (probe, digital input, voltage/current signal) can be configured for each type of input:

- 2 inputs can be configured as temperature probes (NTC type probe) or as digital inputs.
- 4 inputs (AI3...AI6) can be configured as temperature probes (NTC or Pt1000), as digital inputs or as a current/voltage input (4-20mA signal/ 0-10V, 0-5V ratiometric).

Inputs can be configured as specified in the table below.

Parameter	Description	Value								
		0	1	2	3	4	5	6	7	8
Cfg_AI1	Type of analog input AI1	NTC probe (NK103)	Probe configured as voltage-free digital input	NTC probe (103AT)	-	-	-	-	-	-
Cfg_AI2	Type of analog input AI2	NTC probe (NK103)	Probe configured as voltage-free digital input	NTC probe (103AT)	-	-	-	-	-	-
Cfg_AI3	Type of analog input AI3	NTC probe (NK103)	Probe configured as voltage-free digital input	NTC probe (103AT)	4-20 mA (1)	0-10 V (1)	0-5 V Ratiometric (1)	Pt1000	hΩ (NTC) (2)	daΩ (Pt1000) (3)
Cfg_AI4	Type of analog input AI4	NTC probe (NK103)	Probe configured as voltage-free digital input	NTC probe (103AT)	4-20 mA	0-10 V	0-5 V Ratiometric	Pt1000	hΩ (NTC)	daΩ (Pt1000)
Cfg_AI5	Type of analog input AI5	NTC probe (NK103)	Probe configured as voltage-free digital input	NTC probe (103AT)	4-20 mA	0-10 V	0-5 V Ratiometric	Pt1000	hΩ (NTC)	daΩ (Pt1000)
Cfg_AI6	Type of analog input AI6	NTC probe (NK103)	Probe configured as voltage-free digital input	NTC probe (103AT)	4-20 mA	0-10 V	0-5 V Ratiometric	Pt1000	hΩ (NTC)	daΩ (Pt1000)

#### (1) 4-20 mA / 0-10V / 0-5 V ratiometric

##### Minimum full scale AIx

- for current probe, value = 4 mA,
- for 0-10 V voltage probe, value = 0 V,
- for ratiometric probe (0÷5V), value = 10% (corresponding to 0.5 V)

##### Maximum full scale AIx

- for current probe, value = 20 mA,
- for 0-10V voltage probe, value = 10 V,
- for ratiometric probe (0÷5 V), value = 90% (corresponding to 4.5 V)

(2) Cfg\_AIx = 7 Resistance value read, expressed in hΩ, for a resistance applied to the input using the controller in NTC configuration, i.e. **creating a divider with pull-up resistance of 10 kΩ.**

(3) Cfg\_AIx = 8 Resistance value read, expressed in daΩ, for a resistance applied to the input using the controller in Pt1000 configuration, i.e. **creating a divider with pull-up resistance of 2 kΩ.**

Note: Typically used with potentiometer at input.

The resistance range for the hΩ (NTC) configuration is up to 150 K, and up to 30 K for the daΩ (Pt1000) configuration.

Parameter	Range	Description
FullScaleMin_AI3	-9999...+9999	Analog input AI3 start of scale value
FullScaleMax_AI3	-9999...+9999	Analog input AI3 full scale value
FullScaleMin_AI4	-9999...+9999	Analog input AI4 start of scale value
FullScaleMax_AI4	-9999...+9999	Analog input AI4 full scale value
FullScaleMin_AI5	-9999...+9999	Analog input AI5 start of scale value
FullScaleMax_AI5	-9999...+9999	Analog input AI5 full scale value
FullScaleMin_AI6	-9999...+9999	Analog input AI6 start of scale value
FullScaleMax_AI6	-9999...+9999	Analog input AI6 full scale value

The values read by analog inputs can be configured via the following parameters:

Parameter	Description	Measurement Unit	Range
Calibration_AI1	Analog input AI1 differential	°C/10 or °F/10	-180 ... 180
Calibration_AI2	Analog input AI2 differential	°C/10 or °F/10	-180 ... 180
Calibration_AI3	Analog input AI3 differential	-	-1000 ... 1000
Calibration_AI4	Analog input AI4 differential	-	-1000 ... 1000
Calibration_AI5	Analog input AI5 differential	-	-1000 ... 1000
Calibration_AI6	Analog input AI6 differential	-	-1000 ... 1000

### 8.1.2. Analog inputs configuration for M171EP14R

There are a total of 4 analog inputs, referred to below as AI1...AI4.

Using the parameters, a physical resource (probe, digital input, voltage/current signal) can be "physically" configured for each type of input

The inputs are configurable in pairs AI1, AI2 and AI3, AI4

Inputs can be "physically" configured as specified in the table below.

Par	Description	Value										
		0	1	2	3	4	5	6	7	8	9	10
Cfg_AIx x=1...4	Type of analog input AIx	NTC probe (NK103)	DI (1)	NTC probe (103AT)	4-20 mA (2)	0-10 V (2)	0-5 V Ratiometric (2)	Pt1000	hΩ (NTC) (3)	daΩ (Pt1000) (4)	PTC (KTY81)	0-5 V

(1) DI Input configured as voltage-free digital input

(2) **4-20 mA / 0-10 V / 0-5 V ratiometric**

**Minimum full scale AIx**

- for current probe, value = 4 mA,
- for 0-10V voltage probe, value = 0 V,
- for ratiometric probe (0÷5 V), value = 10% (corresponding to 0.5 V)

**Maximum full scale AIx**

- for current probe, value = 20 mA,
- for 0-10 V voltage probe, value = 10 V,
- for ratiometric probe (0÷5V), value = 90% (corresponding to 4.5 V)

(3) Cfg\_AIx = 7 Resistance value read, expressed in hΩ, for a resistance applied to the input using the controller in NTC configuration, i.e. **creating a divider with pull-up resistance of 10 kΩ.**

(4) Cfg\_AIx = 8 Resistance value read, expressed in daΩ, for a resistance applied to the input using the controller in Pt1000 configuration, i.e. **creating a divider with pull-up resistance of 2 kΩ.**

Note: Typically used with potentiometer at input.

The resistance range for the hΩ (NTC) configuration is up to 150 K, and up to 30 K for the daΩ( Pt1000) configuration.

## Allowed configurations for analog inputs

The pairs (AI1, AI2) and (AI3, AI4) shall be configured as specified in the table below.

Cells compiled show correct combinations. Empty cells indicate incorrect combinations.  
Applying incorrect configuration will produce 0x8003 error on probes range configuration

		Cfg_AI1 / Cfg_AI3										
		0	1	2	3	4	5	6	7	8	9	10
Cfg_AI2 / Cfg_AI4	0	NTC probe (NK103)	DI	NTC probe (103AT)	-	-	-	-	hΩ (NTC)	-	-	-
	1	NTC probe (NK103)	DI	NTC probe (103AT)	-	-	-	-	hΩ (NTC)	-	-	-
	2	NTC probe (NK103)	DI	NTC probe (103AT)	-	-	-	-	hΩ (NTC)	-	-	-
	3	-	-	-	4-20 mA	-	-	-	-	-	-	-
	4	-	-	-	-	0-10 V	-	-	-	-	-	-
	5	-	-	-	-	-	0-5 V Ratiometric	-	-	(Pt1000)	-	0-5 V
	6	-	-	-	-	-	-	Pt1000	-	daΩ (Pt1000)	-	-
	7	NTC probe (NK103)	DI	NTC probe (103AT)	-	-	-	-	hΩ (NTC)	-	PTC (KTY81)	-
	8	-	-	-	-	-	-	Pt1000	-	daΩ (Pt1000)	PTC (KTY81)	-
	9	-	-	-	-	-	-	Pt1000	-	daΩ (Pt1000)	PTC (KTY81)	-
	10	-	-	-	-	-	0-5 V Ratiometric	-	-	-	-	0-5 V

### 8.1.3. Analog inputs configuration for M171 Performance Flush

Inputs can be configured as specified in the table below.

Parameter	Description	Values					
		0	1	2	3	4	5
<b>Cfg_AI1</b>	Type of input analog AI1	NTC probe (NK103)	Probe configured as voltage-free digital input	NTC probe (103AT-2)	-	-	-
<b>Cfg_AI2</b>	Type of input analog AI2	NTC probe (NK103)	Probe configured as voltage-free digital input	NTC probe (103AT-2)	-	-	-
<b>Cfg_AI3</b>	Type of input analog AI3	-	-	-	4-20 mA	0-10 V	0-5 V

Parameter	Range	Description
<b>FullScaleMin_AI3</b>	-9999...+9999	Analog input AI3 start of scale value
<b>FullScaleMax_AI3</b>	-9999...+9999	Analog input AI3 full scale value

The temperature and humidity measurement, as well as the corresponding precisions and tolerances, refer to the application point of the probes inside the equipment.

If these same measurements are to be referred to air conditions outside of the equipment, for example ambient measurements, account must be taken of offset (differential) parameters that depend on the installation and usage conditions of the equipment itself. The differentials for example **Calibration** parameters that can be set are:

Parameter	Description	Unit of measure	Range
<b>Calibration_AI1</b>	Analog input AI1 differential	°C/10 or °F/10	-180 ... 180
<b>Calibration_AI2</b>	Analog input AI2 differential	°C/10 or °F/10	-180 ... 180
<b>Calibration_AI3</b>	Analog input AI3 differential	-	-1000 ... 1000
<b>Calibration_AI4</b>	Analog input AI4 differential	-	-1000 ... 1000

For on-board (built-in) sensors, **Compensation** parameters are also available

Parameter	Description	Unit of measure	Range
<b>Compensation_AI1</b>	<b>Internal compensation AI1</b> difference between external air temperature and measurement read by NTC sensor AI1	°C/10 or °F/10	-1000 ... 1000
<b>Compensation_AI4</b>	<b>Internal compensation AI4</b> difference between external temperature and T measurement read by RH sensor AI4 (this temperature is used to calculate the relative humidity based on psychrometric charts)	°C/10 or °F/10	-1000 ... 1000

Default values for these offsets assume a typical installation with wall mounted backplate in a non-ventilated environment and with the display backlighting mainly OFF. In these conditions the following calibration values are obtained:

**Compensation\_AI1** = -12.0 °C (10.4 °F)  
**Compensation\_AI4** = -10.5 °C (13.1 °F)

If the usage conditions require the backlight to be mainly ON, the values must be modified as follows:

**Compensation\_AI1** = -15.0 °C (5.0 °F)  
**Compensation\_AI4** = -13.0 °C (8.6 °F)

**NOTE:** For other mounting conditions carry out **calibration** during installation, checking the temperature and relative humidity differences between the external air and the internal probes and if necessary correcting the parameters **Compensation\_AI1** / **Compensation\_AI4**.

In any case it is possible to achieve a precision of ± 1°C on the temperature measurement and ± 3%RH on the relative humidity measurement.

## 8.2. Analog outputs configuration for M171 Performance

See **CHAPTER 3 Electrical connections on page 24** for the number and type of analog outputs used and for information on the symbols used on labels supplied with the controller.

There are 5 analog outputs with the following characteristics:

### Configuration of analog output

AO1/AO5	AO2	AO3	AO4
Current/voltage output AO1 and AO5 are configured in pairs.	Current/voltage output	Current/voltage output	Current/voltage output
<b>Sub-mode configuration AO5</b> <b>Only if AO1/AO5 have not</b> <b>been configured as voltage outputs (value</b> <b>#2)</b>	-	-	-

Outputs AO1, AO2, AO3, AO4, AO5 are configurable as:

- 0 = 4-20mA current analog output
- 1 = output configured as 0...20mA switch (ON= max 20mA, OFF=0mA) for piloting switch loads such as ON/OFF.
- 2 = 0-10V voltage analog output.

**Outputs AO4, AO5 can be configured as Open Collector output.** Set:

- **Cfg\_AO4** = 1 (ON/OFF type switching)
- **Cfg\_AO1\_AO5** = 0 or 1 (pair of outputs configured as current outputs)
- **SubCfg\_AO5** = 1 (ON/OFF type switching)
- Analog value piloted for both outputs = 0.

**For developers using EcoStruxure Machine Expert HVAC:** see the sysAOasOC function (target block) in the **EcoStruxure Machine Expert HVAC Application Library**

## 8.3. Digital inputs configuration for M171 Performance

There are 8 digital inputs, identified below as DI1...DI8. They are grouped as:

- DI1...DI4
- DI5...DI8

Each one has its own common contact.

Digital inputs can be used as pulse counters.

The length of the pulse (positive or negative) must be greater than 12ms.

There is also a fast, voltage-free digital input that also works as a pulse counter:

- It reads the number of times the contact applied to the input closes.
- It reads frequencies from 0.1 Hz to 1 kHz.

Characteristic	Value		
	<b>FDI: fast digital input</b>		<b>DI1...DI8: regular inputs</b>
Type	Digital input		
Working voltage	0...3.3 Vdc (internal supply)	0...5 Vdc connecting FDI to 5 Vout using a 4700 Ohm resistor	0...24 Vdc / 0...48 Vdc 0...24 Vac 50/60 Hz
Maximum frequency measurement	200 Hz	1000 Hz	-
Level 1	+0...0.8 Vdc		20...24 Vdc / 20...48 Vdc 24 Vac 50/60 Hz
Level 0	2...3.3 Vdc	2...5 Vdc	0...4 Vdc 0...4 Vac 50/60 Hz

## 8.4. Digital outputs configuration for M171 Performance

See **CHAPTER 3 Electrical connections on page 24** for the number and capacity of relays and/or SSR depending on the reference, and for information on the symbols used on labels supplied with the controller.

- There are 7 high voltage outputs (relays) identified as DO1...DO7.
- In references **TM171PDM27S** there are 5 high voltage outputs (relays) identified as DO1...DO3, DO6, DO7 whereas there are 2 SSR outputs identified as DO3...DO4.

## 8.5. Ports configuration for M171 Performance using DipSwitch

Dipswitches are used for the configuration of serial ports, which can be On-Board (**OB**) or available via Communication Module **TM171A●●●●** modules (**PI**).

### 4-position lateral DipSwitch

There is a 4-position lateral DipSwitch (microswitch) in all **TM171PDM27●**, **TM171PBM27R** and **TM171EP●●R** expansion references.

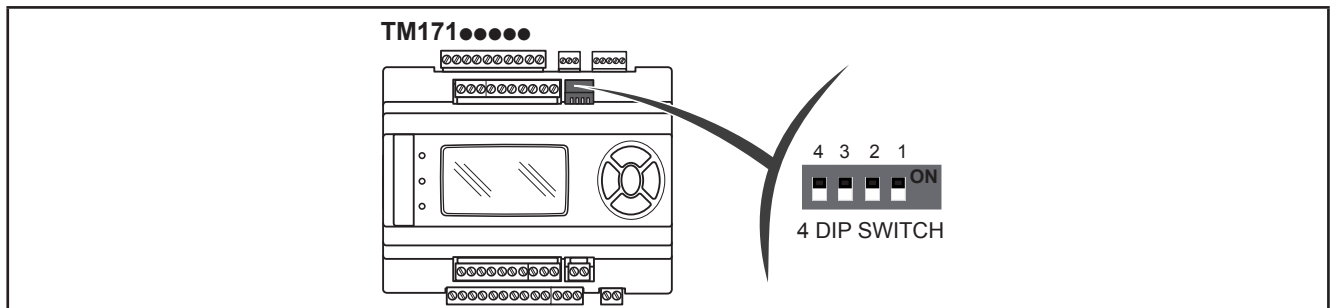

### 6 and 10-position DipSwitch

Under the front panel, **TM171PBM27R** and **TM171EP●●R** expansion references have:

- A 6-position DipSwitch (microswitch) (**SW2**)
- A 10-position DipSwitch (microswitch) (**SW1**)

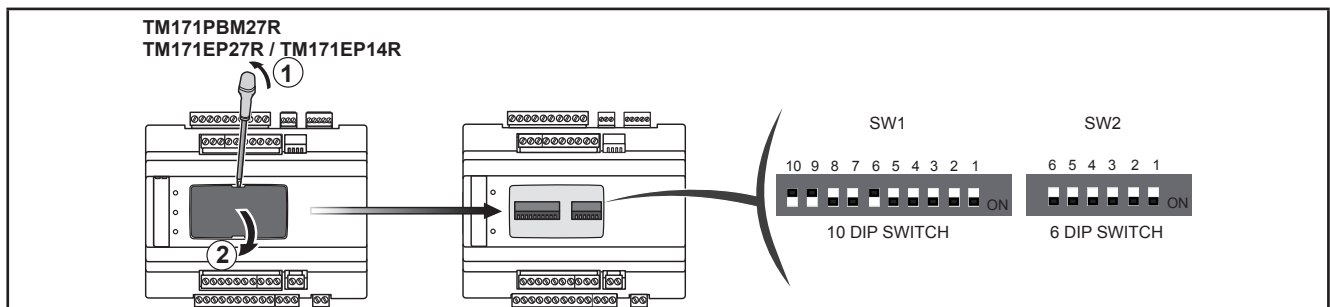

Remove the front panel with a fingernail, or the tip of a slot head screwdriver.  
Configure as necessary then replace the front panel by pressing lightly back into place.

## 4-position DipSwitch compared to 6 and 10-position DipSwitch

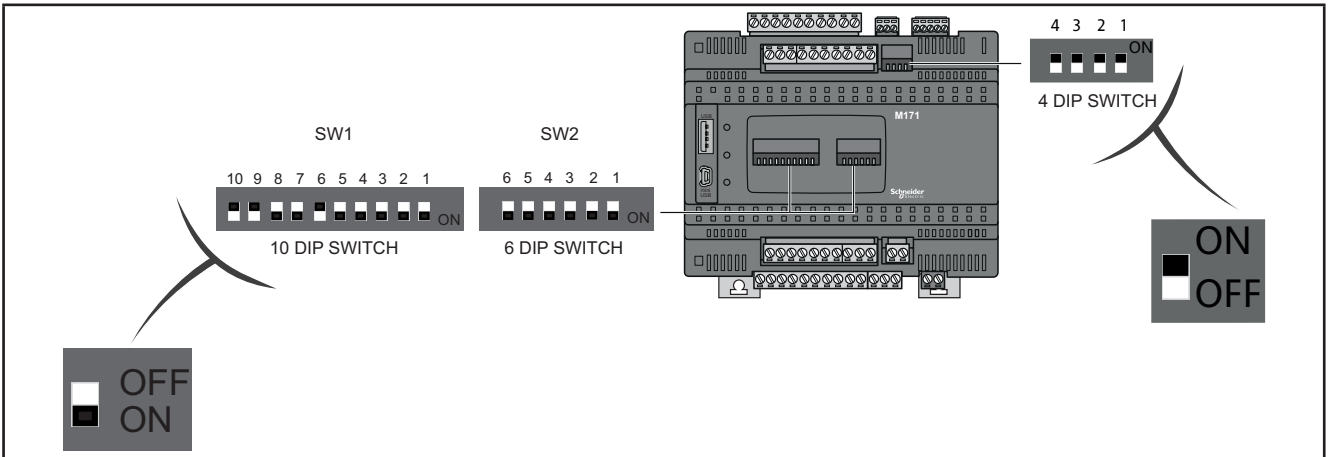

**NOTE.** OFF=0 / ON=1

### 8.5.1. TM171PDM27• DipSwitch

#### 4-position lateral DipSwitch

Used for serial addressing only.

The address is given by the sum of the value of a parameter (1) plus the value defined by the dipswitch (16 addresses).

Serial Addressing Default=0	Dip value	4-position dip			
		Dip4	3	2	1
<div style="text-align: center;"> <p>4 3 2 1</p> <p>LOW Address</p> </div>	0	0	0	0	0
	1	0	0	0	1
	2	0	0	1	0
	3	0	0	1	1
	...	...	...	...	...
	15	1	1	1	1

Address			
Parameter (1)	Default Parameter	+	LOW address Default=0
Addr_RS485_OB	1		
Addr_CAN_OB	1		
Addr_RS485_PI	1		
Addr_CAN_PI	1		
Addr_RS232_PI	1		
Ip_4_ETH_PI	100		

## 8.5.2. TM171PBM27R DipSwitch

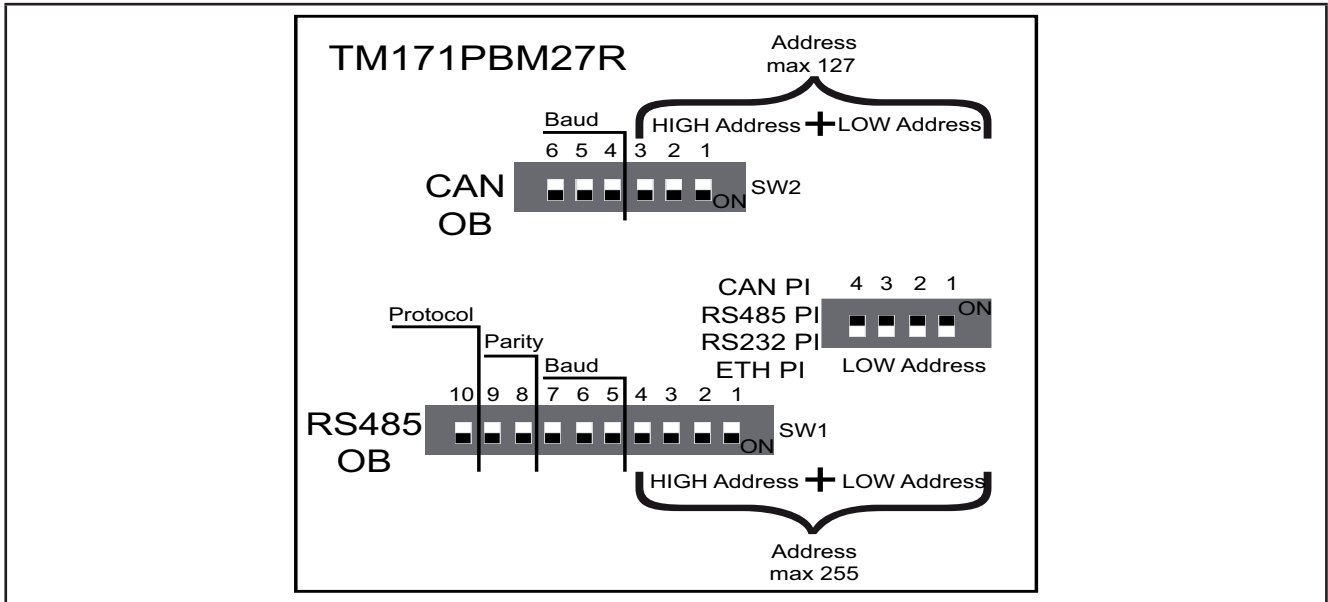

Fig. 59. TM171PBM27R Dipswitch

### Serial addressing

#### 4-position DipSwitch

Used for the serial addressing of the plug-in port (PI) only.

In the serial addressing of On-Board (OB) serial ports, the 4-position dip is not used for TM171PBM27R.

The address is given by the sum of the value of a parameter (1) plus the value defined by the dipswitch (16 addresses).

Serial Addressing Default=0	Dip value	4-position dip			
		Dip4	3	2	1
<p>LOW Address</p>	0	0	0	0	0
	1	0	0	0	1
	2	0	0	1	0
	3	0	0	1	1
	...	...	...	...	...
	15	1	1	1	1

Address			
Parameter (1)	Default Parameter	+	LOW address Default=0
Addr_RS485_PI	1		+
Addr_CAN_PI	1		
Addr_RS232_PI	1		
Ip_4_ETH_PI	100		

## Baud

### 6-position TM171PBM27R DipSwitch

The actual CAN Baud rate comprises the sum of parameter **Baud\_CAN\_OB** plus the composite value of the 3-position dip-switches (8 values).

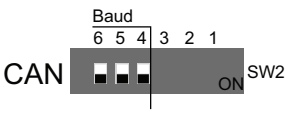
CAN baud selection OB Default = 500 baud	Dip value	Dip6	5	4	3	2	1
	0	0	0	0	-	-	-

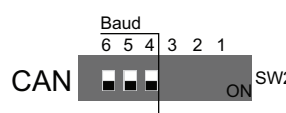
Actual CAN Baud Value Default = 500 baud		Parameter Baud_CAN_OB		CAN baud selection Default = 0
2=500	=	Parameter Baud_CAN_OB	+	
3=250				
4=125				
5=125				
6=50				
default example		2	+	0

## CAN OB serial addressing

### 6-position dipswitch + 4-position dipswitch

The addressing comprises the sum of parameter **Addr\_CAN\_OB** plus the composite value of the 6 and 4-position dipswitches (127 addresses).

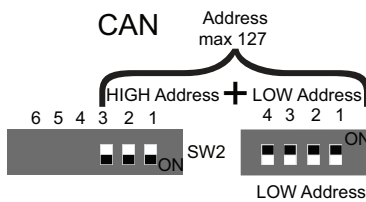
CAN OB serial addressing Default = 1	Dip value	6-position dip HIGH address						4-position dip LOW address			
		Dip6	5	4	3	2	1	Dip4	3	2	1
	0	-	-	-	0	0	0	0	0	0	0
	1	-	-	-	0	0	0	0	0	0	1
	2	-	-	-	0	0	0	0	0	1	0
	3	-	-	-	0	0	0	0	0	1	1
	...	...	...	...	...	...	...	...	...	...	...
	126	-	-	-	1	1	1	1	1	1	0

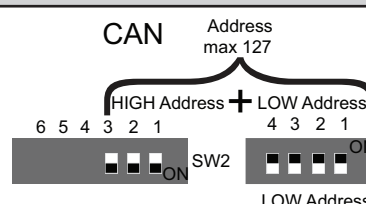
Address		
Parameter		HIGH+LOW address - Default = 0
Addr_CAN_OB	+	
1	+	0

## RS485 OB serial configuration

10-position dipswitch

		Dip value	Dip10	9	8	7	6	5	4	3	2	1	
<b>Protocol selection RS485 OB</b> Default = 1		0	0	-	-	-	-	-	-	-	-	-	
		1	1	-	-	-	-	-	-	-	-	-	-
<b>Parity selection RS485 OB</b> Default = EVEN		0	-	0	0	-	-	-	-	-	-	-	
		1	-	0	1	-	-	-	-	-	-	-	-
		2	-	1	0	-	-	-	-	-	-	-	-
<b>Baud selection RS485 OB</b> Default = 38400 baud		0	-	-	-	0	0	0	-	-	-	-	
		1	-	-	-	0	0	1	-	-	-	-	
		2	-	-	-	0	1	0	-	-	-	-	-
		3	-	-	-	0	1	1	-	-	-	-	-
		4	-	-	-	1	0	0	-	-	-	-	-
		5	-	-	-	1	0	1	-	-	-	-	-

Parameter	Default Parameter		LOW address Default = 0
Proto_RS485_OB	2=Reserved	+	
	3= Modbus RTU		
Parity_RS485_OB	0= NULL	+	
	1= ODD		
	2= EVEN		
Baud_RS485_OB	0=9600	+	
	1=19200		
	2=38400		
	3=57600		
	4=76800		
	5=115200		

## RS485 OB serial addressing

### 10-position dipswitch + 4-position dipswitch

The address is given by the sum of the value of the two 6 and 4-position dipswitches (255 addresses).

Serial addressing RS485 OB Default = 1	Dip value	10-position dip HIGH address					4-position dip LOW address			
		Dip10...5	4	3	2	1	Dip4	3	2	1
	0	-	0	0	0	0	0	0	0	0
	1	-	0	0	0	0	0	0	0	1
	2	-	0	0	0	0	0	0	1	0
	3	-	0	0	0	0	0	0	1	1
	...	...	...	...	...	...	...	...	...	...
254	-	1	1	1	1	1	1	1	0	

Address		
Parameter		LOW address Default = 0
Addr_RS485_OB	+	
1	+	0

**NOTE:** Any other combination of the dipswitches not listed here is not permitted.

To summarize, in the case of **TM171PBM27R**, the default configuration for all dipswitches is as follows:

### TM171PBM27R DipSwitch default configuration

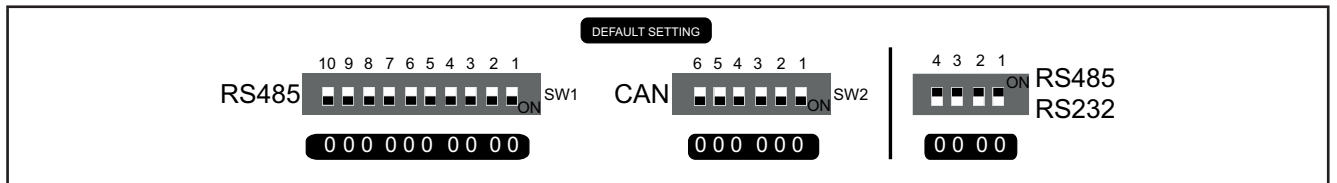

Fig. 60. Default setting

### RS232 OB configuration and serial addressing

6 and 10-position dipswitches are not used.

See [CHAPTER 9 Parameters on page 103](#).

### 8.5.3. TM171EP27R expansion DipSwitch

TM171EP27R expansion serials are configured by configuring dipswitches, without using the "internal" parameters visible in the **CHAPTER 9 Parameters on page 103**.

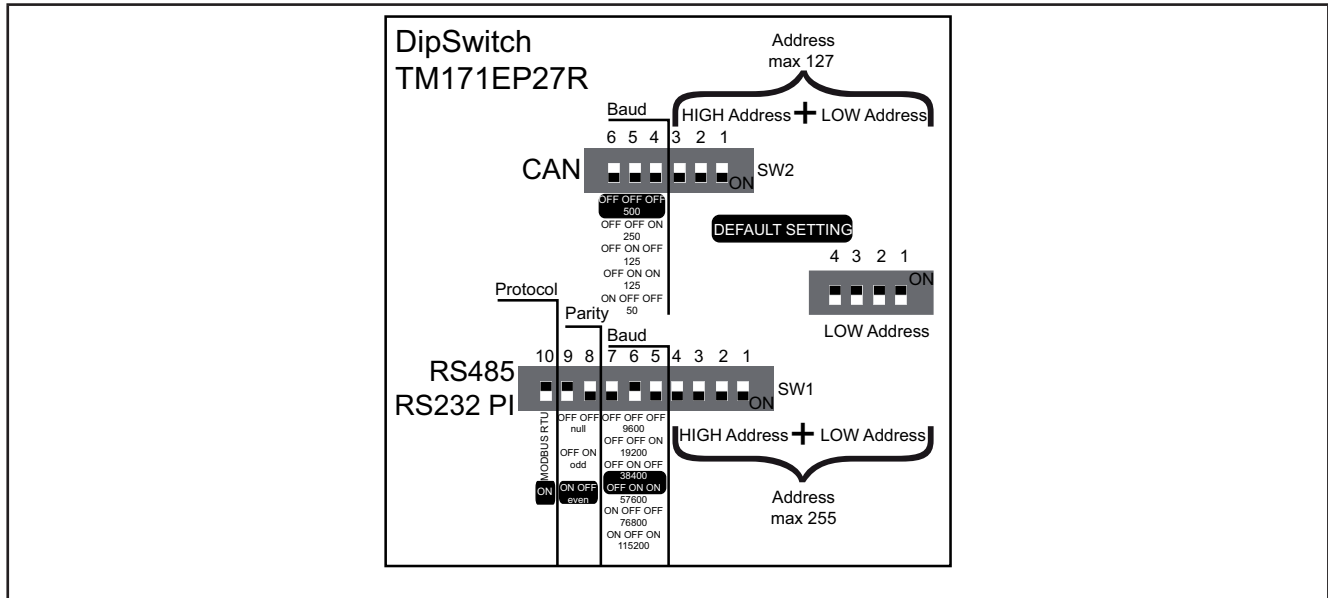

Fig. 61. Dipswitch TM171EP27R

#### Baud

6-position TM171EP27R dipswitch

CAN baud selection OB and PI Default = 500 baud	Baud	Dip value	Dip6	5	4	3	2	1
	500	0	0	0	0	-	-	-
	250	1	0	0	1	-	-	-
	125	2	0	1	0	-	-	-
	125	3	0	1	1	-	-	-
	50	4	1	0	0	-	-	-

#### CAN OB and PI serial addressing

6-position dipswitch + 4-position TM171EP27R dipswitch

The address is given by the value of the 6 and 4-position dipswitches (127 addresses).

CAN serial addressing OB and PI Default = 1	Address	Dip value	6-position dip HIGH address						4-position dip LOW address			
			Dip6	5	4	3	2	1	Dip4	3	2	1
	1	0	-	-	-	0	0	0	0	0	0	0
	2	1	-	-	-	0	0	0	0	0	0	1
	3	2	-	-	-	0	0	0	0	0	1	0
	4	3	-	-	-	0	0	0	0	0	1	1
	...	...	...	...	...	...	...	...	...	...	...	...
	127	126	-	-	-	1	1	1	1	1	1	0

## RS232 PI and RS485 OB serial configuration

10-position dipswitch

		Protocol	Dip value	Dip10	9	8	7	6	5	4	3	2	1	
<b>Protocol selection</b> RS232 PI / RS485 OB Default = 1		Reserved for Schneider Electric use	0	0	-	-	-	-	-	-	-	-	-	
		ModBus RTU	1	1	-	-	-	-	-	-	-	-	-	-
<b>Parity selection</b> RS232 PI / RS485 OB Default = EVEN		Null	0	-	0	0	-	-	-	-	-	-	-	
		Odd	1	-	0	1	-	-	-	-	-	-	-	-
		Even Even	2	-	1	0	-	-	-	-	-	-	-	-
<b>Baud selection</b> RS232 PI / RS485 OB Default = 38400 baud		9600	0	-	-	-	0	0	0	-	-	-	-	
		19200	1	-	-	-	0	0	1	-	-	-	-	
		38400	2	-	-	-	0	1	0	-	-	-	-	-
		57600	3	-	-	-	0	1	1	-	-	-	-	-
		76800	4	-	-	-	1	0	0	-	-	-	-	-
		115200	5	-	-	-	1	0	1	-	-	-	-	-

## RS485 OB and PI serial addressing

10-position dipswitch + 4-position dipswitch

The address is given by the sum of the value of the two 6 and 4-position dipswitches (255 addresses).

CAN serial addressing OB and PI Default = 1	Address	Dip value	10-position dip HIGH address				4-position dip LOW address						
			Dip10...5	4	3	2	1	Dip4	3	2	1		
	1	0	-	0	0	0	0	0	0	0	0	0	
	2	1	-	0	0	0	0	0	0	0	0	1	
	3	2	-	0	0	0	0	0	0	0	1	0	
	4	3	-	0	0	0	0	0	0	0	1	1	
	...	...	...	...	...	...	...	...	...	...	...	...	...
	255	254	-	1	1	1	1	1	1	1	1	1	0

**NOTE:** Any other combination of the dipswitches not listed here is not permitted.

To summarize, in the case of **TM171EP27R**, the default configuration for the dipswitches is as follows:

## TM171EP27R DipSwitch default configuration

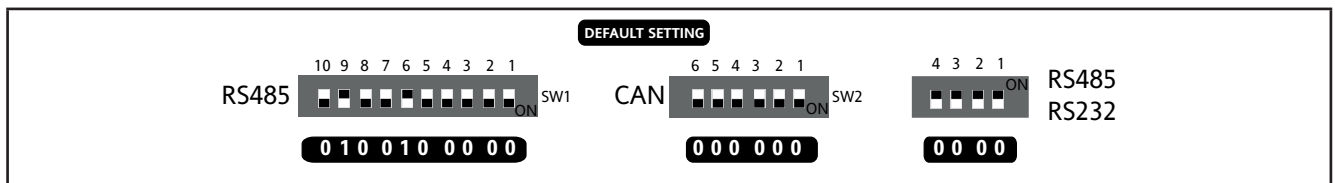

Fig. 62. Default setting

### 8.5.4. TM171EP14R expansion DipSwitch

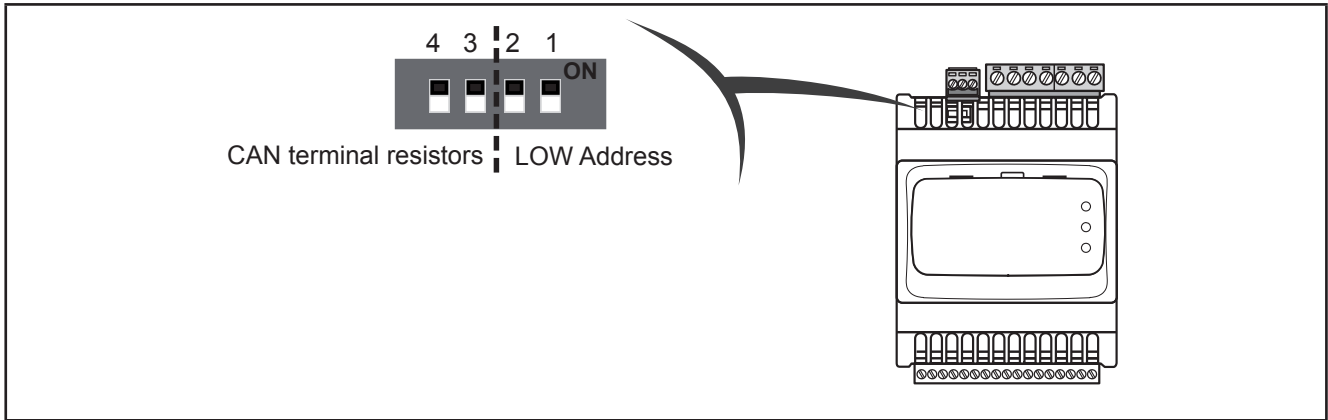

Fig. 63. 4-position lateral DipSwitch

Used for:

- serial addressing (dip 1 and 2)
- line termination (dip 3 and 4)

Serial Addressing	Address = DipValue+1	Dip value	4-position dip			
			Dip4	3	2	1
	1	0	-	-	0	0
	2	1	-	-	0	1
	3	2	-	-	1	0
	4	3	-	-	1	1
	Dip value (Address)	Dip value (Address)	Dip4	3	2	1
	120 Ω termination	120 Ω termination	1	1	-	-

### CAN OB serial addressing

The addressing comprises the sum of parameter **Addr\_CAN\_OB** plus the composite value of the 4-position dipswitches (only dip 1 and 2).

Actual CAN Address Default = 1		Parameter Addr_CAN_OB Default = 1		CAN address selection Default = 0
1	=	Parameter Baud_CAN_OB	+	
2				
...				
...				
127 max				
default example		1	+	0

### Baud

Baud rate is set by **Baud\_CAN\_OB** parameter

### Line Termination resistors

Dip4 and Dip3 both = 1 connects L/H CAN lines to 120 Ω termination

---

## CHAPTER 9

### Parameters

---

User-parameterization renders the **Modicon M171P** configurable.

Parameters can be changed using:

- Keys on the **TM171PDM27** / **M171 Performance Flush** front panel or remote **M171 Performance Display Graphic** (TM171DGRP) panel.
- PC and **EcoStruxure Machine Expert** HVAC software.

The following sections provide a detailed analysis of each parameter, divided into categories (folders).

For **M171 Performance**, the parameter table shows the configuration parameters for the controller saved in the non-volatile memory.

For **M171 Performance Flush**, the parameter table contains the device configuration parameters available in **EcoStruxure Machine Expert** HVAC Device and in the DIAGNOSTICS (DIA) / BIOS Parameters menu.

#### Modbus commands available and data areas

The following commands are implemented:

Modbus command	Description of command
3 (3 hex)	Read multiple registers on Client side
16 (10 hex)	Write multiple registers on Client side
43 (2B hex)	Read device ID: Manufacturer ID Model ID Version ID

#### 9.1. M171 Performance parameter table

This table presents the column headers of the parameter table that follows.

Column	Description
<b>LABEL</b>	Indicates the label used to display the parameters in the menu of the controller.
<b>PAR. VALUE ADDRESS</b>	Indicates the address of the modbus register containing the resource to be accessed.
<b>DATA TYPE</b>	Indicates the type of the data as indicated in EcoStuxure Machine Expert HVAC Installer
<b>CPL</b>	Indicates the register value conversion. To carry out the conversion, proceed as follows: <ul style="list-style-type: none"><li>• If the value in the register is between 0 and 32767, the result is the value itself (zero and positive values)</li><li>• If the value in the register is between 32768 and 65535, the result is the value of the register minus 65536 (negative values)</li><li>• When the field indicates "-1", the value read by the register requires conversion, because the value represents a number with a sign.</li></ul>
<b>RESET</b>	Indicates whether the controller <b>MUST</b> be rebooted after the parameter has been modified. <ul style="list-style-type: none"><li>• Y = YES the controller <b>MUST</b> be rebooted to modify the parameter.</li><li>• Empty " " = NO the controller does not need to be rebooted to modify the parameter</li></ul>
<b>RANGE</b>	Describes the interval of values that can be assigned to the parameter. It can be correlated with other equipment parameters (indicated in the parameter label).
<b>DEFAULT</b>	Indicates the factory setting for the reference.
<b>U.M.</b>	Indicates the unit of measurement for values converted according to the rules indicated in the CPL column The unit of measurement shown is for example purposes only, as it may change depending on the application (for example parameters with a U.M. in °C/bar could also have %RH)

### 9.1.1. TM171PDM27• / TM171PBM27R / TM171EP27R parameters

LABEL	PAR. VALUE ADDRESS	DATA TYPE	CPL	RESET	DESCRIPTION	RANGE	DEFAULT	U.M.
<b>ACKNOWLEDGEMENT folder</b>								
Par_TAB	15716	UINT	-	Y	<b>Map code</b> Note: read/write parameter	0 ... 65535	0	num
Par_POLI	15717	UINT	-	Y	<b>Model Code</b> Note: read/write parameter	0 ... 65535	2049	num
Par_PARMOD	15719	BOOL	-	-	<b>Parameter modified</b> Flag indicating change to default settings. • 0= map not modified. • 1= at least one parameter has been modified with respect to the original configuration.	0 ... 1	0	num
<b>AI CALIBRATION folder</b>								
Gain_Ntc_AI1	15616	UINT	-	-	<b>Ai1 NTC calibration gain</b>	0 ... 65535	32768	num
Gain_Ntc_AI2	15617	UINT	-	-	<b>Ai2 NTC calibration gain</b>	0 ... 65535	32768	num
Gain_Ntc_AI3	15618	UINT	-	-	<b>Ai3 NTC calibration gain</b>	0 ... 65535	32768	num
Gain_Pt1000_AI3	15619	UINT	-	-	<b>Ai3 Pt1000 calibration gain</b>	0 ... 65535	32768	num
Gain_5V_AI3	15620	UINT	-	-	<b>Ai3 0-5V calibration gain</b>	0 ... 65535	32768	num
Gain_10V_AI3	15621	UINT	-	-	<b>Ai3 0-10V calibration gain</b>	0 ... 65535	32768	num
Gain_mA_AI3	15622	UINT	-	-	<b>Ai3 4-20mA calibration gain</b>	0 ... 65535	32768	num
Gain_Ntc_AI4	15623	UINT	-	-	<b>Ai4 NTC calibration gain</b>	0 ... 65535	32768	num
Gain_Pt1000_AI4	15624	UINT	-	-	<b>Ai4 Pt1000 calibration gain</b>	0 ... 65535	32768	num
Gain_5V_AI4	15625	UINT	-	-	<b>Ai4 0-5V calibration gain</b>	0 ... 65535	32768	num
Gain_10V_AI4	15626	UINT	-	-	<b>Ai4 0-10V calibration gain</b>	0 ... 65535	32768	num
Gain_mA_AI4	15627	UINT	-	-	<b>Ai4 4-20mA calibration gain</b>	0 ... 65535	32768	num
Gain_Ntc_AI5	15628	UINT	-	-	<b>Ai5 NTC calibration gain</b>	0 ... 65535	32768	num
Gain_Pt1000_AI5	15629	UINT	-	-	<b>Ai5 Pt1000 calibration gain</b>	0 ... 65535	32768	num
Gain_5V_AI5	15630	UINT	-	-	<b>Ai5 0-5V calibration gain</b>	0 ... 65535	32768	num
Gain_10V_AI5	15631	UINT	-	-	<b>Ai5 0-10V calibration gain</b>	0 ... 65535	32768	num
Gain_mA_AI5	15632	UINT	-	-	<b>Ai5 4-20mA calibration gain</b>	0 ... 65535	32768	num
Gain_Ntc_AI6	15633	UINT	-	-	<b>Ai6 NTC calibration gain</b>	0 ... 65535	32768	num
Gain_Pt1000_AI6	15634	UINT	-	-	<b>Ai6 Pt1000 calibration gain</b>	0 ... 65535	32768	num
Gain_5V_AI6	15635	UINT	-	-	<b>Ai6 0-5V calibration gain</b>	0 ... 65535	32768	num
Gain_10V_AI6	15636	UINT	-	-	<b>Ai6 0-10V calibration gain</b>	0 ... 65535	32768	num
Gain_mA_AI6	15637	UINT	-	-	<b>Ai6 0-10mA calibration gain</b>	0 ... 65535	32768	num
Offs_Ntc_AI1	15650	INT	-1	-	<b>Ai1 NTC calibration offset</b>	-32768 ... 32767	0	num
Offs_Ntc_AI2	15651	INT	-1	-	<b>Ai2 NTC calibration offset</b>	-32768 ... 32767	0	num
Offs_Ntc_AI3	15652	INT	-1	-	<b>Ai3 NTC calibration offset</b>	-32768 ... 32767	0	num
Offs_Pt1000_AI3	15653	INT	-1	-	<b>Ai3 Pt1000 calibration offset</b>	-32768 ... 32767	0	num

LABEL	PAR. VALUE ADDRESS	DATA TYPE	CPL	RESET	DESCRIPTION	RANGE	DEFAULT	U.M.
Offs_5V_AI3	15654	INT	-1	-	Ai3 0-5V calibration offset	-32768 ... 32767	0	num
Offs_10V_AI3	15655	INT	-1	-	Ai3 0-10V calibration offset	-32768 ... 32767	0	num
Offs_mA_AI3	15656	INT	-1	-	Ai3 4-20mA calibration offset	-32768 ... 32767	0	num
Offs_Ntc_AI4	15657	INT	-1	-	Ai4 NTC calibration offset	-32768 ... 32767	0	num
Offs_Pt1000_AI4	15658	INT	-1	-	Ai4 Pt1000 calibration offset	-32768 ... 32767	0	num
Offs_5V_AI4	15659	INT	-1	-	Ai4 0-5V calibration offset	-32768 ... 32767	0	num
Offs_10V_AI4	15660	INT	-1	-	Ai4 0-10V calibration offset	-32768 ... 32767	0	num
Offs_mA_AI4	15661	INT	-1	-	Ai4 4-20mA calibration offset	-32768 ... 32767	0	num
Offs_Ntc_AI5	15662	INT	-1	-	Ai5 NTC calibration offset	-32768 ... 32767	0	num
Offs_Pt1000_AI5	15663	INT	-1	-	Ai5 Pt1000 calibration offset	-32768 ... 32767	0	num
Offs_5V_AI5	15664	INT	-1	-	Ai5 0-5V calibration offset	-32768 ... 32767	0	num
Offs_10V_AI5	15665	INT	-1	-	Ai5 0-10V calibration offset	-32768 ... 32767	0	num
Offs_mA_AI5	15666	INT	-1	-	Ai5 4-20mA calibration offset	-32768 ... 32767	0	num
Offs_Ntc_AI6	15667	INT	-1	-	Ai6 NTC calibration offset	-32768 ... 32767	0	num
Offs_Pt1000_AI6	15668	INT	-1	-	Ai6 Pt1000 calibration offset	-32768 ... 32767	0	num
Offs_5V_AI6	15669	INT	-1	-	Ai6 0-5V calibration offset	-32768 ... 32767	0	num
Offs_10V_AI6	15670	INT	-1	-	Ai6 0-10V calibration offset	-32768 ... 32767	0	num
Offs_mA_AI6	15671	INT	-1	-	Ai6 4-20mA calibration offset	-32768 ... 32767	0	num
<b>AO CALIBRATION folder</b>								
Gain_10V_AO1	15684	UINT	-	-	AO1 0-10V calibration gain	0 ... 65535	32768	num
Gain_mA_AO1	15685	UINT	-	-	AO1 4-20mA calibration gain	0 ... 65535	32768	num
Gain_10V_AO2	15686	UINT	-	-	AO2 0-10V calibration gain	0 ... 65535	32768	num
Gain_mA_AO2	15687	UINT	-	-	AO2 4-20mA calibration gain	0 ... 65535	32768	num
Gain_10V_AO3	15688	UINT	-	-	AO3 0-10V calibration gain	0 ... 65535	32768	num
Gain_mA_AO3	15689	UINT	-	-	AO3 4-20mA calibration gain	0 ... 65535	32768	num
Gain_10V_AO4	15690	UINT	-	-	AO4 0-10V calibration gain	0 ... 65535	32768	num
Gain_mA_AO4	15691	UINT	-	-	AO4 4-20mA calibration gain	0 ... 65535	32768	num
Gain_10V_AO5	15692	UINT	-	-	AO5 0-10V calibration gain	0 ... 65535	32768	num
Gain_mA_AO5	15693	UINT	-	-	AO5 4-20mA calibration gain	0 ... 65535	32768	num
Offs_10V_AO1	15700	UINT	-1	-	AO1 0-10V calibration offset	-32768 ... 32767	0	num
Offs_mA_AO1	15701	UINT	-1	-	AO1 4-20mA calibration offset	-32768 ... 32767	0	num
Offs_10V_AO2	15702	UINT	-1	-	AO2 0-10V calibration offset	-32768 ... 32767	0	num
Offs_mA_AO2	15703	UINT	-1	-	AO2 4-20mA calibration offset	-32768 ... 32767	0	num
Offs_10V_AO3	15704	UINT	-1	-	AO3 0-10V calibration offset	-32768 ... 32767	0	num
Offs_mA_AO3	15705	UINT	-1	-	AO3 4-20mA calibration offset	-32768 ... 32767	0	num
Offs_10V_AO4	15706	UINT	-1	-	AO4 0-10V calibration offset	-32768 ... 32767	0	num

LABEL	PAR. VALUE ADDRESS	DATA TYPE	CPL	RESET	DESCRIPTION	RANGE	DEFAULT	U.M.
Offs_mA_AO4	15707	UINT	-1	-	AO4 4-20mA calibration offset	-32768 ... 32767	0	num
Offs_10V_AO5	15708	UINT	-1	-	AO5 0-10V calibration offset	-32768 ... 32767	0	num
Offs_mA_AO5	15709	UINT	-1	-	AO5 4-20mA calibration offset	-32768 ... 32767	0	num
<b>ANALOG INPUTS folder</b>								
Temp_UM	15725	enum	-	Y	Temperature unit of measurement • 0 = °C; • 1 = °F	0, 1	0	num
Cfg_Ai1	15726	enum	-	-	Type of analog input Ai1 • 0= NTC (NK103) • 1= DI • 2= NTC (103AT)	0 ... 2	2	num
Cfg_Ai2	15727	enum	-	-	Type of analog input Ai2 See Cfg_Ai1	0 ... 2	2	num
Cfg_Ai3	15728	enum	-	-	Type of analog input Ai3 • 0= NTC (NK103) • 1= DI • 2= NTC (103AT) • 3 = 4...20mA • 4=0-10V • 5=0-5V • 6=Pt1000 • 7=hΩ(NTC) • 8=daΩ(Pt1000)	0 ... 8	3	num
Cfg_Ai4	15729	enum	-	-	Type of analog input Ai4 See Cfg_Ai3	0 ... 8	3	num
Cfg_Ai5	15730	enum	-	-	Type of analog input Ai5 See Cfg_Ai3	0 ... 8	3	num
Cfg_Ai6	15731	enum	-	-	Type of analog input Ai6 See Cfg_Ai3	0 ... 8	3	num
FullScaleMin_Ai3	15736	INT	-1	-	Analog input Ai3 start of scale value Note: Minimum full scale: for current probes, value at 4mA, for 0-10V voltage probes, value at 0V, for ratiometric probes (0-5V), value at 10% (corresponding to 0.5V).	-9999...+9999	0	

LABEL	PAR. VALUE ADDRESS	DATA TYPE	CPL	RESET	DESCRIPTION	RANGE	DEFAULT	U.M.
FullScaleMax_Ai3	15737	INT	-	-	<b>Analog input Ai3 full scale value</b> Note: Maximum full scale for current probes, value at 20mA, for 0-10V voltage probes, value at 10V, for ratiometric probes (0-5V), value at 90% (corresponding to 4.5V).	-9999...+9999	1000	
FullScaleMin_Ai4	15738	INT	-1	-	<b>Analog input Ai4 start of scale value</b> See FullScaleMin_Ai3	-9999...+9999	0	
FullScaleMax_Ai4	15739	INT	-	-	<b>Analog input Ai4 full scale value</b> See FullScaleMax_Ai3	-9999...+9999	1000	
FullScaleMin_Ai5	15740	INT	-1	-	<b>Analog input Ai5 start of scale value</b> See FullScaleMin_Ai3	-9999...+9999	0	
FullScaleMax_Ai5	15741	INT	-	-	<b>Analog input Ai5 full scale value</b> See FullScaleMax_Ai3	-9999...+9999	1000	
FullScaleMin_Ai6	15742	INT	-1	-	<b>Analog input Ai6 start of scale value</b> See FullScaleMin_Ai3	-9999...+9999	0	
FullScaleMaxAi6	15743	INT	-	-	<b>Analog input Ai6 full scale value</b> See FullScaleMax_Ai3	-9999...+9999	1000	
Calibration_Ai1	15748	INT	-1	-	<b>Analog input Ai1 differential</b>	-180 ... 180	0	°C/10 or °F/10
Calibration_Ai2	15749	INT	-1	-	<b>Analog input Ai2 differential</b>	-180 ... 180	0	°C/10 or °F/10
Calibration_Ai3	15750	INT	-1	-	<b>Analog input Ai3 differential</b>	-1000 ... 1000	0	
Calibration_Ai4	15751	INT	-1	-	<b>Analog input Ai4 differential</b>	-1000 ... 1000	0	
Calibration_Ai5	15752	INT	-1	-	<b>Analog input Ai5 differential</b>	-1000 ... 1000	0	
Calibration_Ai6	15753	INT	-1	-	<b>Analog input Ai6 differential</b>	-1000 ... 1000	0	

LABEL	PAR. VALUE ADDRESS	DATA TYPE	CPL	RESET	DESCRIPTION	RANGE	DEFAULT	U.M.
<b>ANALOG OUTPUTS VII folder</b>								
Cfg_AO1_AO5	15758	enum	-	Y	<p><b>Type of analog output AO1/AO5</b> AO1 and AO5 are configured in pairs. See SubCfg_AO5</p> <ul style="list-style-type: none"> <li>• 0 = 4-20mA current analog output</li> <li>• 1 = ON/OFF output configured as 0/4...20mA switch (ON= max 20mA, OFF=0mA) for piloting switch loads such as ON/OFF.</li> <li>• 2=0-10V analog output - voltage</li> </ul> <p><b>Note. AO4 and AO5 can be configured as Open Collector → A04=1, A01/A05=0 or 1, SubCfg_AO5=1</b></p>	0 ... 2	0	num
Cfg_AO2	15759	enum	-	Y	<p><b>Type of analog output AO2</b> See Cfg_AO1_AO5</p>	0 ... 2	0	num
Cfg_AO3	15760	enum	-	Y	<p><b>Type of analog output AO3</b> See Cfg_AO1_AO5</p>	0 ... 2	0	num
Cfg_AO4	15761	enum	-	Y	<p><b>Type of analog output AO4</b></p>	0 ... 2	0	num
SubCfg_AO5	15762	enum	-	Y	<p><b>Analog output AO5 sub-mode function</b> Only applies if Cfg_AO1_AO5≠2</p> <ul style="list-style-type: none"> <li>• 0 = 4-20mA current analog output</li> <li>• 1 = ON/OFF output configured as 0/4...20mA switch (ON= max 20mA, OFF=0mA) for piloting switch loads such as ON/OFF.</li> </ul> <p><b>Note. AO4 and AO5 can be configured as Open Collector → A04=1, A01/A05=0 or 1, SubCfg_AO5=1</b></p>	0, 1	0	num

## TM171PDM27● / TM171PBM27R parameters

LABEL	PAR. VALUE ADDRESS	DATA TYPE	CPL	RESET (Y/N)	DESCRIPTION	RANGE	DEFAULT	U.M.
<b>ON BOARD RS485 folder</b>								
Addr_RS485_OB	15774	UINT	-	Y	<b>On-board RS485 serial address</b> The actual address is determined by the sum of this value + the value of the dip switch.	0 ... 255	1	num
Proto_RS485_OB	15775	enum	-	Y	<b>On-board RS485 protocol selection</b> • 2 = uNET • 3 = Modbus/RTU	2 ... 3	3	num
Databit_RS485_OB	15776	UINT	-	Y	<b>On-board RS485 data bit number</b> Fixed setting 8	8 ... 8	8	num
Stopbit_RS485_OB	15777	UINT	-	Y	<b>On-board RS485 stop bit number</b> 1= 1 stop bit 2= 2 stop bit	1... 2	1	num
Parity_RS485_OB	15778	enum	-	Y	<b>On-board RS485 protocol parity</b> • 0= NULL • 1= ODD • 2= EVEN	0 ... 2	2	num
Baud_RS485_OB	15779	enum	-	Y	<b>On-board RS485 protocol baudrate</b> • 0=9600 baud • 1=19200 baud • 2=38400 baud • 3=57600 baud • 4=76800 baud • 5=115200 baud	0 ... 5	2	num
<b>ON BOARD CAN folder</b>								
Addr_CAN_OB	15780	UINT	-	Y	<b>On-board CAN serial address</b> The actual address is determined by the sum of this value + the value of the dip switch.	1 ... 127	1	num
Baud_CAN_OB	15781	enum	-	Y	<b>On-board CAN protocol baudrate</b> • 2=500 kbaud • 3=250 kbaud • 4=125 kbaud • 5=125 kbaud • 6=50 kbaud	2 ... 6	2	num
<b>CAN PLUGIN PASSIVE folder</b>								
Addr_RS485_PI	15782	UINT	-	Y	<b>RS485 passive plug-in serial address</b> The actual address is determined by the sum of this value + the value of the dip switch.	0 ... 255	1	num

LABEL	PAR. VALUE ADDRESS	DATA TYPE	CPL	RESET (Y/N)	DESCRIPTION	RANGE	DEFAULT	U.M.
Proto_RS485_PI	15783	enum	-	Y	<b>RS485 passive plug-in protocol selection</b> 2 = uNET 3 = Modbus/RTU	2 ... 3	3	num
Databit_RS485_PI	15784	UINT	-	Y	<b>RS485 passive plug-in data bit number</b> Fixed setting 8	8 ... 8	8	num
Stopbit_RS485_PI	15785	UINT	-	Y	<b>RS485 passive plug-in stop bit number</b> • 1= 1 stop bit • 2= 2 stop bit	1... 2	1	num
Parity_RS485_PI	15786	enum	-	Y	<b>RS485 passive plug-in protocol parity</b> 0= NULL 1= ODD 2= EVEN	0 ... 2	2	num
Baud_RS485_PI	15787	enum	-	Y	<b>RS485 passive plug-in protocol baudrate</b> • 0=9600 baud • 1=19200 baud • 2=38400 baud • 3=57600 baud • 4=76800 baud • 5=115200 baud	0 ... 5	2	num
Addr_CAN_PI	15788	UINT	-	Y	<b>CAN passive plug-in serial address</b> The actual address is determined by the sum of this value + the value of the dip switch.	1 ... 127	1	num
Baud_CAN_PI	15789	enum	-	Y	<b>CAN passive plug-in protocol baudrate</b> • 2=500 kbaud • 3=250 kbaud • 4=125 kbaud • 5=125 kbaud • 6=50 kbaud	2 ... 6	2	num
<b>RS232 PASSIVE PLUG-IN folder</b>								
Addr_RS232_PI	15790	UINT	-	Y	<b>RS232 passive plug-in serial address</b> The actual address is determined by the sum of this value + the value of the dip switch.	0 ... 255	1	num
Proto_RS232_PI	15791	enum	-	Y	<b>RS232 passive plug-in protocol selection</b> • 2 = uNET • 3 = Modbus/RTU	2 ... 3	3	num

LABEL	PAR. VALUE ADDRESS	DATA TYPE	CPL	RESET (Y/N)	DESCRIPTION	RANGE	DEFAULT	U.M.
Databit_RS232_PI	15792	UINT	-	Y	<b>RS232 passive plug-in data bit number</b> <ul style="list-style-type: none"> <li>• 7= 7 bit</li> <li>• 8= 8 bit</li> </ul>	7 ... 8	8	num
Stopbit_RS232_PI	15793	UINT	-	Y	<b>RS232 passive plug-in stop bit number</b> <ul style="list-style-type: none"> <li>• 1= 1 stop bit</li> <li>• 2= 2 stop bit</li> </ul>	1... 2	1	num
Parity_RS232_PI	15784	enum	-	Y	<b>RS232 passive plug-in protocol parity</b> <ul style="list-style-type: none"> <li>• 0= NULL</li> <li>• 1= ODD</li> <li>• 2= EVEN</li> </ul>	0 ... 2	2	num
Baud_RS232_PI	15795	enum	-	Y	<b>RS232 passive plug-in protocol baudrate</b> <ul style="list-style-type: none"> <li>• 0=9600 baud</li> <li>• 1=19200 baud</li> <li>• 2=38400 baud</li> <li>• 3=57600 baud</li> <li>• 4=76800 baud</li> <li>• 5=115200 baud</li> </ul>	0 ... 5	2	num

## PASSIVE ETHERNET COMMUNICATION MODULE

ETHERNET configuration parameters for passive plug-in require configuration of the TCP/IP communication port (for example 502), the IP address, the gateway and the subnet mask

The 'Default Gateway' and 'Net mask' parameters are of no significance in the local point-to-point network.

For connections via a router the 'Default Gateway' parameters must match the IP address, as in the following example:

		Value			Value
Ip_1_ETH_PI	Ethernet Passive Plug-In IP address (part 1)	192	DefGtwy_1_ETH_PI	Default Gateway (part 1)	192
Ip_2_ETH_PI	Ethernet Passive Plug-In IP address (part 2)	168	DefGtwy_2_ETH_PI	Default Gateway (part 2)	168
Ip_3_ETH_PI	Ethernet Passive Plug-In IP address (part 3)	0	DefGtwy_3_ETH_PI	Default Gateway (part 3)	0
Ip_4_ETH_PI	Ethernet Passive Plug-In IP address (part 4)	100	DefGtwy_4_ETH_PI	Default Gateway (part 4)	1

The parameters necessary for the configuration of ports and protocols are these:

**WebVisu** allows the use of HTTP and TFTP servers.

Parameter	Description	Label
HTTP ports	<b>HTTP HyperText Transfer Protocol.</b> An HTTP server generally monitors port 80 using TCP protocol.	Port_HTTP_PI
TFTP ports	<b>TFTP Trivial File Transfer Protocol.</b> Protocol using basic FTP functionalities. Typical use: transfer of small files between hosts on a network. TFTP USES PORT 69	Port_TFTP_PI
DHCP protocol	<b>DHCP Dynamic Host Configuration Protocol</b>	EnableDHCP_ETH_PI
DNS system	<b>DNS Domain Name System</b> System for the conversion of host names, or network nodes, to IP addresses Used by <b>EcoStruxure Machine Expert</b> HVAC to send text e-mails (strings)	PriDNS_1_ETH_PI
		PriDNS_2_ETH_PI
		PriDNS_3_ETH_PI
		PriDNS_4_ETH_PI
		SecDNS_1_ETH_PI
		SecDNS_2_ETH_PI
		SecDNS_3_ETH_PI
		SecDNS_4_ETH_PI

LABEL	PAR VALUE ADDRESS	DATA TYPE	CPL	RESET (Y/N)	DESCRIPTION	RANGE	DEFAULT	U.M.
<b>ETHERNET PASSIVE PLUG-IN folder</b>								
Port_TFTP_PI	15772	UINT	-	Y	<b>TFTP port</b> TFTP communication Port number Default 0 corresponds to <b>port 69</b>	0 ... 65535	0	num
Port_HTTP_PI	15796	UINT	-	Y	<b>HTTP port</b> HTTP communication Port number Default 0 corresponds to <b>port 80</b>	0 ... 65535	0	num
Port_ETH_PI	15797	UINT	-	Y	<b>Port</b> TCP/IP Modbus communication port. Port 502 for example	0 ... 65535	502	num
Ip_1_ETH_PI	15798	UINT	-	Y	<b>Ethernet passive Plug-in IP address (part 1)</b>	0 ... 255	10	num
Ip_2_ETH_PI	15799	UINT	-	Y	<b>Ethernet passive Plug-in IP address (part 2)</b>	0 ... 255	0	num
Ip_3_ETH_PI	15800	UINT	-	Y	<b>Ethernet passive Plug-in IP address (part 3)</b>	0 ... 255	0	num
Ip_4_ETH_PI	15801	UINT	-	Y	<b>Ethernet passive Plug-in IP address (part 4)</b>	0 ... 255	100	num
DefGtwy_1_ETH_PI	15802	UINT	-	Y	<b>Default Gateway (part 1)</b>	0 ... 255	192	num
DefGtwy_2_ETH_PI	15803	UINT	-	Y	<b>Default Gateway (part 2)</b>	0 ... 255	168	num
DefGtwy_3_ETH_PI	15804	UINT	-	Y	<b>Default Gateway (part 3)</b>	0 ... 255	0	num
DefGtwy_4_ETH_PI	15805	UINT	-	Y	<b>Default Gateway (part 4)</b>	0 ... 255	1	num
NetMsk_1_ETH_PI	15806	UINT	-	Y	<b>Net mask (part 1)</b>	0 ... 255	255	num
NetMsk_2_ETH_PI	15807	UINT	-	Y	<b>Net mask (part 2)</b>	0 ... 255	255	num
NetMsk_3_ETH_PI	15808	UINT	-	Y	<b>Net mask (part 3)</b>	0 ... 255	255	num
NetMsk_4_ETH_PI	15809	UINT	-	Y	<b>Net mask (part 4)</b>	0 ... 255	0	num
PriDNS_1_ETH_PI	15810	UINT	-	Y	<b>Primary DNS server (part 1)</b>	0 ... 255	194	num
PriDNS_2_ETH_PI	15811	UINT	-	Y	<b>Primary DNS server (part 2)</b>	0 ... 255	25	num
PriDNS_3_ETH_PI	15812	UINT	-	Y	<b>Primary DNS server (part 3)</b>	0 ... 255	2	num
PriDNS_4_ETH_PI	15813	UINT	-	Y	<b>Primary DNS server (part 4)</b>	0 ... 255	129	num
SecDNS_1_ETH_PI	15814	UINT	-	Y	<b>Secondary DNS server (part 1)</b>	0 ... 255	194	num

LABEL	PAR VALUE ADDRESS	DATA TYPE	CPL	RESET (Y/N)	DESCRIPTION	RANGE	DEFAULT	U.M.
SecDNS_2_ETH_PI	15815	UINT	-	Y	Secondary DNS server (part 2)	0 ... 255	25	num
SecDNS_3_ETH_PI	15816	UINT	-	Y	Secondary DNS server (part 3)	0 ... 255	2	num
SecDNS_4_ETH_PI	15817	UINT	-	Y	Secondary DNS server (part 4)	0 ... 255	130	num
EnableDHCP_ETH_PI	15819	BOOL	-	Y	Enable DHCP	0 ... 1 (False, True)	False	flag
<b>Modems folder</b>								
Modem_RS232_PI	15820	BOOL	-	Y	Presence of Modem	0 ... 1	0	num
Modem_InitStr1	15821	STRING 19 BYTES	-	Y	Modem initialization string (part I)	*****	(1)	string
Modem_InitStr2	15831	STRING 19 BYTES	-	Y	Modem initialization string (part II)	*****		string
Modem_Hangup	15851	STRING 19 BYTES	-	Y	Hangup String	*****	ATH0	string
<b>Display folder</b>								
Hmi_Language	15819	UINT	-	Y	Display language	0 ... 65535	0	num
Par_ContrLCD	15723	UINT	-	Y	<b>LCD Contrast</b> Allows adjustment of the LCD display contrast.	0 ... 64	30	num
Par_BackLightTime	15724	UINT	-	Y	<b>Backlight switch-on time</b> Allows adjustment of LCD display switch-on time.	0 ... 3600	10	num
(1) AT&F&C&D2E0X1S0=0								

## 9.1.2. M171EP14R parameters

LABEL	PAR. VALUE ADDRESS	DATA TYPE	CPL	RESET (Y/N)	DESCRIPTION	RANGE	DEFAULT	U.M.
<b>ACKNOWLEDGEMENT folder</b>								
Par_TAB	15716	UINT	-	Y	<b>Map code</b> Note: read/write parameter	0 ... 65535	0	num
Par_POLI	15717	UINT	-	Y	<b>Model Code</b> Note: read/write parameter	0 ... 65535	2049	num
Par_PCH	15718	UINT	-	-	<b>Model ID Code</b>	0 ... 65535	262	num
<b>AI CALIBRATION folder</b>								
Gain_Ntc_AI1	15616	UINT	-	-	<b>Ai1 NTC calibration gain</b>	0 ... 65535	32768	num
Gain_Ntc_AI2	15617	UINT	-	-	<b>Ai2 NTC calibration gain</b>	0 ... 65535	32768	num
Gain_Ntc_AI3	15618	UINT	-	-	<b>Ai3 NTC calibration gain</b>	0 ... 65535	32768	num
Gain_Ntc_AI4	15619	UINT	-	-	<b>Ai4 NTC calibration gain</b>	0 ... 65535	32768	num
Offs_Ntc_AI1	15621	INT	-1	-	<b>Ai1 NTC calibration offset</b>	-32768 ... 32767	0	num
Offs_Ntc_AI2	15622	INT	-1	-	<b>Ai2 NTC calibration offset</b>	-32768 ... 32767	0	num
Offs_Ntc_AI3	15623	INT	-1	-	<b>Ai3 NTC calibration offset</b>	-32768 ... 32767	0	num
Offs_Ntc_AI4	15624	INT	-1	-	<b>Ai4 NTC calibration offset</b>	-32768 ... 32767	0	num
Gain_PTC_AI1	15626	UINT	-	-	<b>Ai1 PTC calibration gain</b>	0 ... 65535	32768	num
Gain_PTC_AI2	15627	UINT	-	-	<b>Ai2 PTC calibration gain</b>	0 ... 65535	32768	num
Gain_PTC_AI3	15628	UINT	-	-	<b>Ai3 PTC calibration gain</b>	0 ... 65535	32768	num
Gain_PTC_AI4	15629	UINT	-	-	<b>Ai4 PTC calibration gain</b>	0 ... 65535	32768	num
Offs_PTC_AI1	15631	INT	-1	-	<b>Ai1 PTC calibration offset</b>	-32768 ... 32767	0	num
Offs_PTC_AI2	15632	INT	-1	-	<b>Ai2 PTC calibration offset</b>	-32768 ... 32767	0	num
Offs_PTC_AI3	15633	INT	-1	-	<b>Ai3 PTC calibration offset</b>	-32768 ... 32767	0	num
Offs_PTC_AI4	15634	INT	-1	-	<b>Ai4 PTC calibration offset</b>	-32768 ... 32767	0	num
Gain_daOhm_AI1	15636	UINT	-	-	<b>Ai1 daOhm calibration gain</b>	0 ... 65535	32768	num
Gain_daOhm_AI2	15637	UINT	-	-	<b>Ai2 daOhm calibration gain</b>	0 ... 65535	32768	num
Gain_daOhm_AI3	15638	UINT	-	-	<b>Ai3 daOhm calibration gain</b>	0 ... 65535	32768	num
Gain_daOhm_AI4	15639	UINT	-	-	<b>Ai4 daOhm calibration gain</b>	0 ... 65535	32768	num
Offs_daOhm_AI1	15641	INT	-1	-	<b>Ai1 daOhm calibration offset</b>	-32768 ... 32767	0	num
Offs_daOhm_AI2	15642	INT	-1	-	<b>Ai2 daOhm calibration offset</b>	-32768 ... 32767	0	num
Offs_daOhm_AI3	15643	INT	-1	-	<b>Ai3 daOhm calibration offset</b>	-32768 ... 32767	0	num
Offs_daOhm_AI4	15644	INT	-1	-	<b>Ai4 daOhm calibration offset</b>	-32768 ... 32767	0	num
Gain_mA_AI1	15646	UINT	-	-	<b>Ai1 4-20mA calibration gain</b>	0 ... 65535	32768	num
Gain_mA_AI2	15647	UINT	-	-	<b>Ai2 4-20mA calibration gain</b>	0 ... 65535	32768	num

LABEL	PAR. VALUE ADDRESS	DATA TYPE	CPL	RESET (Y/N)	DESCRIPTION	RANGE	DEFAULT	U.M.
Gain_mA_AI3	15648	UINT	-	-	Ai3 4-20mA calibration gain	0 ... 65535	32768	num
Gain_mA_AI4	15649	UINT	-	-	Ai4 4-20mA calibration gain	0 ... 65535	32768	num
Offs_mA_AI1	15651	INT	-1	-	Ai1 4-20mA calibration offset	-32768 ... 32767	0	num
Offs_mA_AI2	15652	INT	-1	-	Ai2 4-20mA calibration offset	-32768 ... 32767	0	num
Offs_mA_AI3	15653	INT	-1	-	Ai3 4-20mA calibration offset	-32768 ... 32767	0	num
Offs_mA_AI4	15654	INT	-1	-	Ai4 4-20mA calibration offset	-32768 ... 32767	0	num
Gain_5V_Ratio_AI1	15656	UINT	-	-	Ai1 5V Ratiometric calibration gain	0 ... 65535	32768	num
Gain_5V_Ratio_AI2	15657	UINT	-	-	Ai2 5V Ratiometric calibration gain	0 ... 65535	32768	num
Gain_5V_Ratio_AI3	15658	UINT	-	-	Ai3 5V Ratiometric calibration gain	0 ... 65535	32768	num
Gain_5V_Ratio_AI4	15659	UINT	-	-	Ai4 5V Ratiometric calibration gain	0 ... 65535	32768	num
Offs_5V_Ratio_AI1	15661	INT	-1	-	Ai1 5V Ratiometric calibration offset	-32768 ... 32767	0	num
Offs_5V_Ratio_AI2	15662	INT	-1	-	Ai2 5V Ratiometric calibration offset	-32768 ... 32767	0	num
Offs_5V_Ratio_AI3	15663	INT	-1	-	Ai3 5V Ratiometric calibration offset	-32768 ... 32767	0	num
Offs_5V_Ratio_AI4	15664	INT	-1	-	Ai4 5V Ratiometric calibration offset	-32768 ... 32767	0	num
Gain_10V_AI1	15666	UINT	-	-	Ai1 0-10V calibration gain	0 ... 65535	32768	num
Gain_10V_AI2	15667	UINT	-	-	Ai2 0-10V calibration gain	0 ... 65535	32768	num
Gain_10V_AI3	15668	UINT	-	-	Ai3 0-10V calibration gain	0 ... 65535	32768	num
Gain_10V_AI4	15669	UINT	-	-	Ai4 0-10V calibration gain	0 ... 65535	32768	num
Offs_10V_AI1	15671	INT	-1	-	Ai1 0-10V calibration offset	-32768 ... 32767	0	num
Offs_10V_AI2	15672	INT	-1	-	Ai2 0-10V calibration offset	-32768 ... 32767	0	num
Offs_10V_AI3	15673	INT	-1	-	Ai3 0-10V calibration offset	-32768 ... 32767	0	num
Offs_10V_AI4	15674	INT	-1	-	Ai4 0-10V calibration offset	-32768 ... 32767	0	num
Gain_5V_AI1	15676	UINT	-	-	Ai1 0-5V calibration gain	0 ... 65535	32768	num
Gain_5V_AI2	15677	UINT	-	-	Ai2 0-5V calibration gain	0 ... 65535	32768	num
Gain_5V_AI3	15678	UINT	-	-	Ai3 0-5V calibration gain	0 ... 65535	32768	num
Gain_5V_AI4	15679	UINT	-	-	Ai4 0-5V calibration gain	0 ... 65535	32768	num
Offs_5V_AI1	15681	INT	-1	-	Ai1 0-5V calibration offset	-32768 ... 32767	0	num
Offs_5V_AI2	15682	INT	-1	-	Ai2 0-5V calibration offset	-32768 ... 32767	0	num
Offs_5V_AI3	15683	INT	-1	-	Ai3 0-5V calibration offset	-32768 ... 32767	0	num
Offs_5V_AI4	15684	INT	-1	-	Ai4 0-5V calibration offset	-32768 ... 32767	0	num
Gain_Pt1000_AI1	15686	UINT	-	-	Ai1 Pt1000 calibration gain	0 ... 65535	32768	num
Gain_Pt1000_AI2	15687	UINT	-	-	Ai2 Pt1000 calibration gain	0 ... 65535	32768	num
Gain_Pt1000_AI3	15688	UINT	-	-	Ai3 Pt1000 calibration gain	0 ... 65535	32768	num
Gain_Pt1000_AI4	15689	UINT	-	-	Ai4 Pt1000 calibration gain	0 ... 65535	32768	num

LABEL	PAR. VALUE ADDRESS	DATA TYPE	CPL	RESET (Y/N)	DESCRIPTION	RANGE	DEFAULT	U.M.
Offs_Pt1000_AI1	15691	INT	-1	-	Ai1 Pt1000 calibration offset	-32768 ... 32767	0	num
Offs_Pt1000_AI2	15692	INT	-1	-	Ai2 Pt1000 calibration offset	-32768 ... 32767	0	num
Offs_Pt1000_AI3	15693	INT	-1	-	Ai3 Pt1000 calibration offset	-32768 ... 32767	0	num
Offs_Pt1000_AI4	15694	INT	-1	--	Ai4 Pt1000 calibration offset	-32768 ... 32767	0	num
<b>AO CALIBRATION folder</b>								
Gain_10V_AO1	15696	UINT	-	-	AO1 0-10V calibration gain	0 ... 65535	32768	num
Gain_10V_AO2	15697	UINT	-	-	AO2 0-10V calibration gain	0 ... 65535	32768	num
Offs_10V_AO1	15698	INT	-1	-	AO1 0-10V calibration offset	-32768 ... 32767	0	num
Offs_10V_AO2	15699	INT	-1	-	AO2 0-10V calibration offset	-32768 ... 32767	0	num
<b>ANALOG INPUTS folder</b>								
Temp_UM	15725	enum	-	Y	Temperature unit of measurement • 0 = °C; • 1 = °F	0, 1	0	num
Cfg_Ai1	15726	enum	-	-	Type of analog input Ai1 • 0= NTC (NK103) • 1= DI • 2= NTC (103AT) • 3 = 4...20mA • 4=0-10V • 5=0-5V Ratiometric • 6=Pt1000 • 7=hΩ(NTC) • 8=daΩ(Pt1000) • PTC • 10=0-5V	0 ... 10	3	num
Cfg_Ai2	15727	enum	-	-	Type of analog input Ai2 See Cfg_Ai1	0 ... 10	3	num
Cfg_Ai3	15728	enum	-	-	Type of analog input Ai3 See Cfg_Ai1	0 ... 10	2	num
Cfg_Ai4	15729	enum	-	-	Type of analog input Ai4 See Cfg_Ai1	0 ... 10	2	num
FullScaleMin_Ai1	15736	INT	-1	-	Analog input Ai1 start of scale value	-9999...+9999	0	
FullScaleMax_Ai1	15737	INT	-	-	Analog input Ai1 full scale value	-9999...+9999	1000	
FullScaleMin_Ai2	15738	INT	-1	-	Analog input Ai2 start of scale value See FullScaleMin_Ai1	-9999...+9999	0	

LABEL	PAR. VALUE ADDRESS	DATA TYPE	CPL	RESET (Y/N)	DESCRIPTION	RANGE	DEFAULT	U.M.
FullScaleMax_A2	15739	INT	-	-	Analog input Ai2 full scale value See FullScaleMax_Ai1	-999...+999	1000	
FullScaleMin_Ai3	15740	INT	-1	-	Analog input Ai3 start of scale value See FullScaleMin_Ai1	-9999...+9999	0	
FullScaleMax_Ai3	15741	INT	-	-	Analog input Ai3 full scale value See FullScaleMax_Ai1	-999...+999	1000	
FullScaleMin_Ai4	15742	INT	-1	-	Analog input Ai4 start of scale value See FullScaleMin_Ai1	-9999...+9999	0	
FullScaleMaxAi4	15743	INT	-	-	Analog input Ai4 full scale value See FullScaleMax_Ai1	-999...+999	100	
Calibration_Ai1	15748	INT	-1	-	Analog input Ai1 differential	-180 ... 180	0	°C/10 or °F/10
Calibration_Ai2	15749	INT	-1	-	Analog input Ai2 differential	-180 ... 180	0	°C/10 or °F/10
Calibration_Ai3	15750	INT	-1	-	Analog input Ai3 differential	-1000 ... 1000	0	
Calibration_Ai4	15751	INT	-1	-	Analog input Ai4 differential	-1000 ... 1000	0	
SubCfg_AI1	16010	enum	-	Y	Analog input Ai5 sub-mode function  <ul style="list-style-type: none"> <li>• 0 = Low Pass Filter disabled, analog value in raw points</li> <li>• 1 = Low Pass Filter disabled, analog value converted</li> <li>• 2 = Low Pass Filter enabled, analog value in raw points</li> <li>• 1 = Low Pass Filter enabled, analog value converted</li> </ul>	0 ... 3	3	num
SubCfg_AI2	16011	enum	-	Y	See SubCfg_AI1	0 ... 3	3	num
SubCfg_AI3	16012	enum	-	Y	See SubCfg_AI1	0 ... 3	3	num
SubCfg_AI4	16013	enum	-	Y	See SubCfg_AI1	0 ... 3	3	num
<b>ON BOARD CAN folder</b>								
Addr_CAN_OB	15780	UINT	-	Y	<b>On-board CAN serial address</b> The actual address is determined by the sum of this value + the value of the dip switch.	1 ... 127	1	num

LABEL	PAR. VALUE ADDRESS	DATA TYPE	CPL	RESET (Y/N)	DESCRIPTION	RANGE	DEFAULT	U.M.
Baud_CAN_OB	15781	enum	-	Y	<b>On-board CAN protocol baudrate</b> <ul style="list-style-type: none"> <li>• 2=500 kbaud</li> <li>• 3=250 kbaud</li> <li>• 4=125 kbaud</li> <li>• 5=125 kbaud</li> <li>• 6=50 kbaud</li> </ul>	2 ... 6	2	num

### 9.1.3. M171 Performance Flush parameters

LABEL	PAR VALUE ADDRESS	DATA TYPE	CPL	RESET (Y/N)	DESCRIPTION	RANGE	DEFAULT	U.M.
<b>ACKNOWLEDGEMENT folder</b>								
Par_TAB	15716	UINT	-	Y	<b>Map code</b> Note: read/write parameter	0 ... 65535	0	num
Par_POLI	15717	UINT	-	Y	<b>Model Code</b> Note: read/write parameter	0 ... 65535	2049	num
Par_PARMOD	15719	BOOL	-	-	<b>Parameter changed</b> Flag indicating change to default settings. <ul style="list-style-type: none"> <li>0= map not modified.</li> <li>1= at least one parameter has been changed from the original configuration.</li> </ul>	0 ... 1	0	num
<b>AI CALIBRATION folder</b>								
Gain_Ntc_AI1	15616	UINT	-	-	<b>Ai1 NTC calibration gain</b>	0 ... 65535	32768	num
Gain_Ntc_AI2	15617	UINT	-	-	<b>Ai2 NTC calibration gain</b>	0 ... 65535	32768	num
Gain_5V_AI3	15620	UINT	-	-	<b>Ai3 0-5V calibration gain</b>	0 ... 65535	32768	num
Gain_10V_AI3	15621	UINT	-	-	<b>Ai3 0-10V calibration gain</b>	0 ... 65535	32768	num
Gain_mA_AI3	15622	UINT	-	-	<b>Ai3 4-20mA calibration gain</b>	0 ... 65535	32768	num
Offs_Ntc_AI1	15650	INT	-1	-	<b>Ai1 NTC calibration offset</b>	-32768 ... 32767	0	num
Offs_Ntc_AI2	15651	INT	-1	-	<b>Ai2 NTC calibration offset</b>	-32768 ... 32767	0	num
Offs_5V_AI3	15654	INT	-1	-	<b>Ai3 0-5V calibration offset</b>	-32768 ... 32767	0	num
Offs_10V_AI3	15655	INT	-1	-	<b>Ai3 0-10V calibration offset</b>	-32768 ... 32767	0	num
Offs_mA_AI3	15656	INT	-1	-	<b>Ai3 4-20mA calibration offset</b>	-32768 ... 32767	0	num
<b>ANALOG INPUTS folder</b>								
Temp_UM	15725	enum	-	Y	<b>Temperature unit of measure</b> <ul style="list-style-type: none"> <li>0 = °C;</li> <li>1 = °F</li> </ul>	0, 1	0	num
Cfg_AI1	15726	enum	-	-	<b>Type of analog input Ai1</b> <ul style="list-style-type: none"> <li>0= NTC (NK103)</li> <li>1= DI</li> <li>2= NTC (103AT)</li> </ul>	0 ... 2	2	num
Cfg_AI2	15727	enum	-	-	<b>Type of analog input Ai2</b> See Cfg_AI1	0 ... 2	2	num

LABEL	PAR VALUE ADDRESS	DATA TYPE	CPL	RESET (Y/N)	DESCRIPTION	RANGE	DEFAULT	U.M.
Cfg_Ai3	15728	enum	-	-	<b>Type of analog input Ai3</b> <ul style="list-style-type: none"> <li>3 = 4...20mA</li> <li>4=0-10V</li> <li>5=0-5V</li> </ul>	3 ... 5	3	num
Cfg_Ai4	15729	enum	-	-	<b>Type of analog input Ai4</b> See Cfg_Ai3	3 ... 5	3	num
FullScaleMin_Ai3	15736	INT	-1	-	<b>Analog input Ai3 start of scale value</b> N.B.: Minimum full scale: for current probes, value at 4mA, for 0-10V voltage probes, value at 0V, 10% for ( 0-5V) probes, value at 10% (corresponding to 0.5V).	-9999...+9999	0	
FullScaleMax_Ai3	15737	INT	-1	-	<b>Analog input Ai3 full scale value</b> N.B.: Maximum full scale for current probes, value at 20mA, for 0-10V voltage probes, value at 10V, for (0-5V) probes, value at 90% (corresponding to 4.5V).	-9999...+9999	1000	
Calibration_Ai1	15748	INT	-1	-	<b>Analog input Ai1 differential</b>	-180 ... 180	0	°C/10 or °F/10
Calibration_Ai2	15749	INT	-1	-	<b>Analog input Ai2 differential</b>	-180 ... 180	0	°C/10 or °F/10
Calibration_Ai3	15750	INT	-1	-	<b>Analog input Ai3 differential</b>	-1000 ... 1000	0	
Calibration_Ai4	15751	INT	-1	-	<b>Analog input Ai4 differential</b>	-1000 ... 1000	0	
Compensation_AI1	15752	INT	-1	-	<b>Internal compensation AI1</b>	-1000 ... 1000 °C/10	0	°C/10
Compensation_AI4	15753	INT	-1	-	<b>Internal compensation AI4</b>	-1000 ... 1000 °C/10	0	°C/10
<b>RS485 ON BOARD folder</b>								
Addr_RS485_OB	15774	UINT	-	Y	<b>On-board RS485 serial address</b> The actual address is determined by the sum of this value + the value of the dip switch.	0 ... 255	1	num
Proto_RS485_OB	15775	enum	-	Y	<b>On-board RS485 protocol selection</b> <ul style="list-style-type: none"> <li>2 = uNET</li> <li>3 = Modbus/RTU</li> </ul>	2 ... 3	2	num
Databit_RS485_OB	15776	UINT	-	Y	<b>On-board RS485 data bit number</b> Fixed setting 8	8 ... 8	8	num
Stopbit_RS485_OB	15777	UINT	-	Y	<b>On-board RS485 stop bit number</b> <ul style="list-style-type: none"> <li>1= 1 stop bit</li> <li>2= 2 stop bits</li> </ul>	1... 2	1	num

LABEL	PAR VALUE ADDRESS	DATA TYPE	CPL	RESET (Y/N)	DESCRIPTION	RANGE	DEFAULT	U.M.
Parity_RS485_OB	15778	enum	-	Y	<b>On-board RS485 protocol parity</b> <ul style="list-style-type: none"> <li>• 0= NULL</li> <li>• 1= ODD</li> <li>• 2= EVEN</li> </ul>	0 ... 2	2	num
Baud_RS485_OB	15779	enum	-	Y	<b>On-board RS485 protocol baudrate</b> <ul style="list-style-type: none"> <li>• 0=9600 baud</li> <li>• 1=19200 baud</li> <li>• 2=38400 baud</li> <li>• 3=57600 baud</li> <li>• 4=76800 baud</li> <li>• 5=115200 baud</li> </ul>	0 ... 5	2	num
<b>ON BOARD CAN folder</b>								
Addr_CAN_OB	15780	UINT	-	Y	<b>On-board CAN serial address</b> The actual address is determined by the sum of this value + the value of the dip switch.	1 ... 127	1	num
Baud_CAN_OB	15781	UINT	-	Y	<b>On-board CAN protocol baudrate</b> <ul style="list-style-type: none"> <li>2=500 kbaud</li> <li>3=250 kbaud</li> <li>4=125 kbaud</li> <li>5=125 kbaud</li> <li>6=50 kbaud</li> </ul>	2 ... 6	2	num

## ON BOARD ETHERNET

The parameters necessary for the configuration of ports and protocols are these:

WebVisu allows the use of HTTP and TFTP servers.

Parameter	Description	Label
HTTP ports	<b>HTTP HyperText Transfer Protocol.</b> An HTTP server generally monitors port 80 using TCP protocol.	Port_HTTP
TFTP ports	<b>TFTP Trivial File Transfer Protocol.</b> Protocol using basic FTP functionalities. Typical use: transfer of small files between hosts on a network. TFTP USES PORT 69	Port_TFTP
DHCP protocol	<b>DHCP Dynamic Host Configuration Protocol</b>	EnableDHCP_ETH

Parameter	Description	Label
DNS system	<b>DNS Domain Name System</b> System for the conversion of host names, or network nodes, to IP addresses Used by <b>EcoStruxure Machine Expert</b> HVAC to send text e-mails (strings)	PriDNS_1_ETH
		PriDNS_2_ETH
		PriDNS_3_ETH
		PriDNS_4_ETH
		SecDNS_1_ETH
		SecDNS_2_ETH
		SecDNS_3_ETH
		SecDNS_4_ETH

LABEL	PAR VALUE ADDRESS	DATA TYPE	CPL	RESET (Y/N)	DESCRIPTION	RANGE	DEFAULT	U.M.
<b>ETHERNET ON BOARD folder</b>								
Port_TFTP	15772	UINT	-	Y	<b>TFTP port</b> TFTP communication Port number Default 0 corresponds to <b>port 69</b>	0 ... 65535	0	num
Port_HTTP	15796	UINT	-	Y	<b>HTTP port</b> HTTP communication Port number Default 0 corresponds to <b>port 80</b>	0 ... 65535	0	num
Port_ETH	15797	UINT	-	Y	<b>Port</b> TCP/IP Modbus communication port. Port 502 for example	0 ... 65535	502	num
Ip_1_ETH	15798	UINT	-	Y	<b>On-board Ethernet passive IP address (part 1)</b>	0 ... 255	10	num
Ip_2_ETH	15799	UINT	-	Y	<b>On-board Ethernet passive IP address (part 2)</b>	0 ... 255	0	num
Ip_3_ETH	15800	UINT	-	Y	<b>On-board Ethernet passive IP address (part 3)</b>	0 ... 255	0	num
Ip_4_ETH	15801	UINT	-	Y	<b>On-board Ethernet passive IP address (part 4)</b>	0 ... 255	100	num
DefGtwy_1_ETH	15802	UINT	-	Y	<b>Default Gateway (part 1)</b>	0 ... 255	192	num
DefGtwy_2_ETH	15803	UINT	-	Y	<b>Default Gateway (part 2)</b>	0 ... 255	168	num
DefGtwy_3_ETH	15804	UINT	-	Y	<b>Default Gateway (part 3)</b>	0 ... 255	0	num
DefGtwy_4_ETH	15805	UINT	-	Y	<b>Default Gateway (part 4)</b>	0 ... 255	1	num
NetMsk_1_ETH	15806	UINT	-	Y	<b>Net mask (part 1)</b>	0 ... 255	255	num
NetMsk_2_ETH	15807	UINT	-	Y	<b>Net mask (part 2)</b>	0 ... 255	255	num
NetMsk_3_ETH	15808	UINT	-	Y	<b>Net mask (part 3)</b>	0 ... 255	255	num
NetMsk_4_ETH	15809	UINT	-	Y	<b>Net mask (part 4)</b>	0 ... 255	0	num
PriDNS_1_ETH	15810	UINT	-	Y	<b>Primary DNS server (part 1)</b>	0 ... 255	194	num
PriDNS_2_ETH	15811	UINT	-	Y	<b>Primary DNS server (part 2)</b>	0 ... 255	25	num
PriDNS_3_ETH	15812	UINT	-	Y	<b>Primary DNS server (part 3)</b>	0 ... 255	2	num
PriDNS_4_ETH	15813	UINT	-	Y	<b>Primary DNS server (part 4)</b>	0 ... 255	129	num
SecDNS_1_ETH	15814	UINT	-	Y	<b>Secondary DNS server (part 1)</b>	0 ... 255	194	num
SecDNS_2_ETH	15815	UINT	-	Y	<b>Secondary DNS server (part 2)</b>	0 ... 255	25	num

LABEL	PAR VALUE ADDRESS	DATA TYPE	CPL	RESET (Y/N)	DESCRIPTION	RANGE	DEFAULT	U.M.
SecDNS_3_ETH	15816	UINT		Y	Secondary DNS server (part 3)	0 ... 255	2	num
SecDNS_4_ETH	15817	UINT	-	Y	Secondary DNS server (part 4)	0 ... 255	130	num
EnableDHCP_ETH	15819	BOOL	-	Y	Enable DHCP	0 ... 1 (False, True)	False	flag
<b>Display folder</b>								
Hmi_Language	15819	enum	-	-	<b>Display language</b> 0 = Italian 1 = English 2 = French 3 = German 4 = Spanish	0 ... 65535	0	num
Par_ContrLCD	15723	UINT	-	Y	<b>LCD Contrast</b> Allows adjustment of the LCD display contrast.	0 ... 64	30	num
Par_BackLightTime	15724	UINT	-	-	<b>Backlight switch-on time</b> Allows adjustment of LCD display switch-on time.	0 ... 3600	10	sec
<b>Buzzer folder</b>								
Buzzer_Mode	15990	enum	-	-	<b>Buzzer mode</b> 0= always off 1= beep per key	0 ... 1	0	num
<b>HMI Management folder</b>								
Hmi_Language	15989	UINT			<b>Language</b>	0 ... 65535	0	num
HmiList_Current	15820	enum	-	-	Current HMI 0= HMI remote 1 1= HMI remote 2 2= HMI remote 3 3= HMI remote 4 4= HMI remote 5 5= HMI remote 6 6= HMI remote 7 7= HMI remote 8 8= HMI remote 9 9= HMI remote 10 10 = not used 11= Local HMI	0 ... 11	11	num
<b>If HmiList_Current=11 the following folders/parameters are NOT USED.</b>								
<b>HMI remote 1 folder</b>								
HmiList_ID_1	15821	UINT	-	-	HMI remote 1 navigation ID list	0 ... 254	0	num
HmiList_Res_1	15833	enum	-	-	HMI remote 1 navigation resource type HMI remote 1 navigation resource type 1=RTU (RS485 Modbus RTU) 2=TCP (Modbus TCP) 3=CAN (CAN)	1 ... 3	3	num
HmiList_Addr_1	15845	UINT	-	-	HMI remote 1 navigation resource address for CAN, RTU and TCP (IP part 1)	0 ... 255	0	num

LABEL	PAR VALUE ADDRESS	DATA TYPE	CPL	RESET (Y/N)	DESCRIPTION	RANGE	DEFAULT	U.M.
HmiList_Addr_2	15846	UINT	-	-	HMI remote 1 navigation resource address for TCP (IP part 2)	0 ... 255	0	num
HmiList_Addr_3	15847	UINT	-	-	HMI remote 1 navigation resource address for TCP (IP part 3)	0 ... 255	0	num
HmiList_Addr_4	15848	UINT	-	-	HMI remote 1 navigation resource address for TCP (IP part 4)	0 ... 255	0	num
HmiList_File_1	15893	STRING 15 byte	-	-	HMI remote 1 navigation file (DOS 8.3 uppercase format)	*****		string
<b>HMI remote 2 folder</b>								
HmiList_ID_2	15822	UINT	-	-	HMI remote 2 navigation ID list	0 ... 254	0	num
HmiList_Res_2	15834	enum	-	-	HMI remote 2 navigation resource type 1=RTU (RS485 Modbus RTU) 2=TCP (Modbus TCP) 3=CAN (CAN)	1 ... 3	3	num
HmiList_Addr_1	15849	UINT	-	-	HMI remote 2 navigation resource address for CAN, RTU and TCP (IP part 1)	0 ... 255	0	num
HmiList_Addr_2	15850	UINT	-	-	HMI remote 2 navigation resource address for TCP (IP part 2)	0 ... 255	0	num
HmiList_Addr_3	15851	UINT	-	-	HMI remote 2 navigation resource address for TCP (IP part 3)	0 ... 255	0	num
HmiList_Addr_4	15852	UINT	-	-	HMI remote 2 navigation resource address for TCP (IP part 4)	0 ... 255	0	num
HmiList_File_2	15901	STRING 15 byte	-	-	HMI remote 2 navigation file (DOS 8.3 uppercase format)	*****		string
<b>HMI remote 3 folder</b>								
HmiList_ID_3	15823	UINT	-	-	HMI remote 2 navigation ID list	0 ... 254	0	num
HmiList_Res_3	15835	enum	-	-	HMI remote 3 navigation resource type 1=RTU (RS485 Modbus RTU) 2=TCP (Modbus TCP) 3=CAN (CAN)	1 ... 3	3	num
HmiList_Addr_1	15853	UINT	-	-	HMI remote 3 navigation resource address for CAN, RTU and TCP (IP part 1)	0 ... 255	0	num
HmiList_Addr_2	15854	UINT	-	-	HMI remote 3 navigation resource address for TCP (IP part 2)	0 ... 255	0	num
HmiList_Addr_3	15855	UINT	-	-	HMI remote 3 navigation resource address for TCP (IP part 3)	0 ... 255	0	num
HmiList_Addr_4	15856	UINT	-	-	HMI remote 3 navigation resource address for TCP (IP part 4)	0 ... 255	0	num
HmiList_File_3	15909	STRING 15 byte	-	-	HMI remote 3 navigation file (DOS 8.3 uppercase format)	*****		string
<b>HMI remote 4 folder</b>								
HmiList_ID_4	15824	UINT	-	-	HMI remote 4 navigation ID list	0 ... 254	0	num

LABEL	PAR VALUE ADDRESS	DATA TYPE	CPL	RESET (Y/N)	DESCRIPTION	RANGE	DEFAULT	U.M.
HmiList_Res_4	15836	enum	-	-	HMI remote 4 navigation resource type 1=RTU (RS485 Modbus RTU) 2=TCP (Modbus TCP) 3=CAN (CAN)	1 ... 3	3	num
HmiList_Addr_1	15857	UINT	-	-	HMI remote 4 navigation resource address for CAN, RTU and TCP (IP part 1)	0 ... 255	0	num
HmiList_Addr_2	15859	UINT	-	-	HMI remote 4 navigation resource address for TCP (IP part 2)	0 ... 255	0	num
HmiList_Addr_3	15859	UINT	-	-	HMI remote 4 navigation resource address for TCP (IP part 3)	0 ... 255	0	num
HmiList_Addr_4	15860	UINT	-	-	HMI remote 4 navigation resource address for TCP (IP part 4)	0 ... 255	0	num
HmiList_File_4	15917	STRING 15 byte	-	-	HMI remote 4 navigation file (DOS 8.3 uppercase format)	*****		string
<b>HMI remote 5 folder</b>								
HmiList_ID_5	15825	UINT	-	-	HMI remote 5 navigation ID list	0 ... 254	0	num
HmiList_Res_5	15837	enum	-	-	HMI remote 5 navigation resource type 1=RTU (RS485 Modbus RTU) 2=TCP (Modbus TCP) 3=CAN (CAN)	1 ... 3	3	num
HmiList_Addr_1	15861	UINT	-	-	HMI remote 5 navigation resource address for CAN, RTH and TCP (IP part 1)	0 ... 255	0	num
HmiList_Addr_2	15862	UINT	-	-	HMI remote 5 navigation resource address for TCP (IP part 2)	0 ... 255	0	num
HmiList_Addr_3	15863	UINT	-	-	HMI remote 5 navigation resource address for TCP (IP part 3)	0 ... 255	0	num
HmiList_Addr_4	15864	UINT	-	-	HMI remote 5 navigation resource address for TCP (IP part 4)	0 ... 255	0	num
HmiList_File_5	15925	STRING 15 byte	-	-	HMI remote 5 navigation file (DOS 8.3 uppercase format)	*****		string
<b>HMI remote 6 folder</b>								
HmiList_ID_6	15826	UINT	-	-	HMI remote 6 navigation ID list	0 ... 254	0	num
HmiList_Res_6	15838	enum	-	-	HMI remote 6 navigation resource type 1=RTU (RS485 Modbus RTU) 2=TCP (Modbus TCP) 3=CAN (CAN)	1 ... 3	3	num
HmiList_Addr_1	15865	UINT	-	-	HMI remote 6 navigation resource address for CAN, RTH and TCP (IP part 1)	0 ... 255	0	num
HmiList_Addr_2	15866	UINT	-	-	HMI remote 6 navigation resource address for TCP (IP part 2)	0 ... 255	0	num
HmiList_Addr_3	15867	UINT	-	-	HMI remote 6 navigation resource address for TCP (IP part 3)	0 ... 255	0	num

LABEL	PAR VALUE ADDRESS	DATA TYPE	CPL	RESET (Y/N)	DESCRIPTION	RANGE	DEFAULT	U.M.
HmiList_Addr_4	15868	UINT	-	-	HMI remote 6 navigation resource address for TCP (IP part 4)	0 ... 255	0	num
HmiList_File_6	15933	STRING 15 byte	-	-	HMI remote 6 navigation file (DOS 8.3 uppercase format)	*****		string
<b>HMI remote 7 folder</b>								
HmiList_ID_7	15827	UINT	-	-	HMI remote 7 navigation ID list	0 ... 254	0	num
HmiList_Res_7	15839	enum	-	-	HMI remote 7 navigation resource type 1=RTU (RS485 Modbus RTU) 2=TCP (Modbus TCP) 3=CAN (CAN)	1 ... 3	3	num
HmiList_Addr_1	15869	UINT	-	-	HMI remote 7 navigation resource address for CAN, RTU and TCP (IP part 1)	0 ... 255	0	num
HmiList_Addr_2	15870	UINT	-	-	HMI remote 7 navigation resource address for TCP (IP part 2)	0 ... 255	0	num
HmiList_Addr_3	15871	UINT	-	-	HMI remote 7 navigation resource address for TCP (IP part 3)	0 ... 255	0	num
HmiList_Addr_4	15872	UINT	-	-	HMI remote 7 navigation resource address for TCP (IP part 4)	0 ... 255	0	num
HmiList_File_7	15941	STRING 15 byte			HMI remote 7 navigation file (DOS 8.3 uppercase format)	*****		string
<b>HMI remote 8 folder</b>								
HmiList_ID_8	15828	UINT	-	-	HMI remote 8 navigation ID list	0 ... 254	0	num
HmiList_Res_8	15840	enum	-	-	HMI remote 8 navigation resource type 1=RTU (RS485 Modbus RTU) 2=TCP (Modbus TCP) 3=CAN (CAN)	1 ... 3	3	num
HmiList_Addr_1	15873	UINT	-	-	HMI remote 8 navigation resource address for CAN, RTU and TCP (IP part 1)	0 ... 255	0	num
HmiList_Addr_2	15874	UINT	-	-	HMI remote 8 navigation resource address for TCP (IP part 2)	0 ... 255	0	num
HmiList_Addr_3	15875	UINT	-	-	HMI remote 8 navigation resource address for TCP (IP part 3)	0 ... 255	0	num
HmiList_Addr_4	15876	UINT	-	-	HMI remote 8 navigation resource address for TCP (IP part 4)	0 ... 255	0	num
HmiList_File_8	15949	STRING 15 byte	-	-	HMI remote 8 navigation file (DOS 8.3 uppercase format)	*****		string
<b>HMI remote 9 folder</b>								
HmiList_ID_9	15829	UINT	-	-	HMI remote 9 navigation ID list	0 ... 254	0	num
HmiList_Res_9	15841	enum	-	-	HMI remote 9 navigation resource type 1=RTU (RS485 Modbus RTU) 2=TCP (Modbus TCP) 3=CAN (CAN)	1 ... 3	3	num

LABEL	PAR VALUE ADDRESS	DATA TYPE	CPL	RESET (Y/N)	DESCRIPTION	RANGE	DEFAULT	U.M.
HmiList_Addr_1	15877	UINT	-	-	HMI remote 9 navigation resource address for CAN, RTU and TCP (IP part 1)	0 ... 255	0	num
HmiList_Addr_2	15878	UINT	-	-	HMI remote 9 navigation resource address for TCP (IP part 2)	0 ... 255	0	num
HmiList_Addr_3	15879	UINT	-	-	HMI remote 9 navigation resource address for TCP (IP part 3)	0 ... 255	0	num
HmiList_Addr_4	15880	UINT	-	-	HMI remote 9 navigation resource address for TCP (IP part 4)	0 ... 255	0	num
HmiList_File_9	15957	STRING 15 byte	-	-	HMI remote 9 navigation file (DOS 8.3 uppercase format)	*****		string
<b>HMI remote 10 folder</b>								
HmiList_ID_10	15830	UINT	-	-	HMI remote 10 navigation ID list	0 ... 254	0	num
HmiList_Res_10	15842	enum	-	-	HMI remote 10 navigation resource type 1=RTU (RS485 Modbus RTU) 2=TCP (Modbus TCP) 3=CAN (CAN)	1 ... 3	3	num
HmiList_Addr_1	15881	UINT	-	-	HMI remote 10 navigation resource address for CAN, RTU and TCP (IP part 1)	0 ... 255	0	num
HmiList_Addr_2	15882	UINT	-	-	HMI remote 10 navigation resource address for TCP (IP part 2)	0 ... 255	0	num
HmiList_Addr_3	15883	UINT	-	-	HMI remote 10 navigation resource address for TCP (IP part 3)	0 ... 255	0	num
HmiList_Addr_4	15884	UINT	-	-	HMI remote 10 navigation resource address for TCP (IP part 4)	0 ... 255	0	num
HmiList_File_10	15965	STRING 15 byte	-	-	HMI remote 10 navigation file (DOS 8.3 uppercase format)	*****		string

## CHAPTER 10

### Programming of the TM171EP14R

The **TM171ADMI** and **TM171AMFK** are accessories that can be connected to the **M171 Performance TM171EP14R expansion** (target) serial port to make a quick programming of :

- Targets parameters (upload and download of a parameter map to/from one or more targets of the same type)
- Targets BIOS

#### Connection of Programming Cable (TM171ADMI)

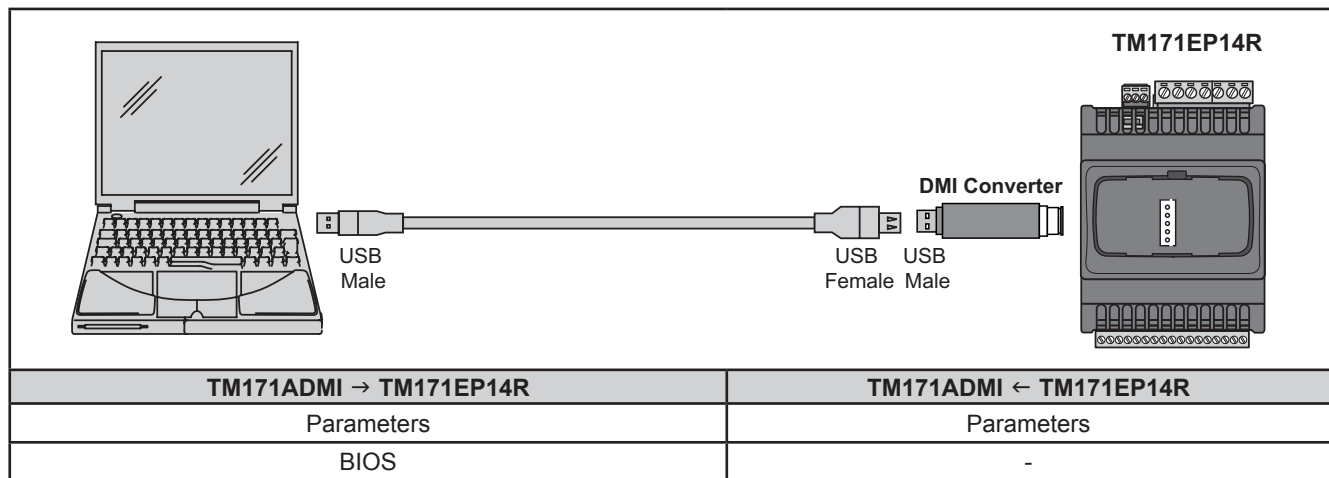

**Fig. 64.** Connections between TM171ADMI Converter and the Modicon TM171EP14R

**NOTE:** When supplying power to the expansion module from the PC, **TM171EP14R** must not be connected to earth. If a ground (earth) connection exists for the PC as well as the **TM171EP14R** a ground loop condition could develop and render either PC or the **TM171EP14R** inoperable.

### NOTICE

#### INOPERABLE EQUIPMENT

If you are unsure whether the TM171EP14R is connected to an SELV power supply, disconnect the power supply connection to the TM171EP14R before connecting a PC.

**Failure to follow these instructions can result in equipment damage.**

## Connection of Multi Function Key (TM171AMFK)

To connect TM171AMFK to TM171ADMI the BLUE cable is used.

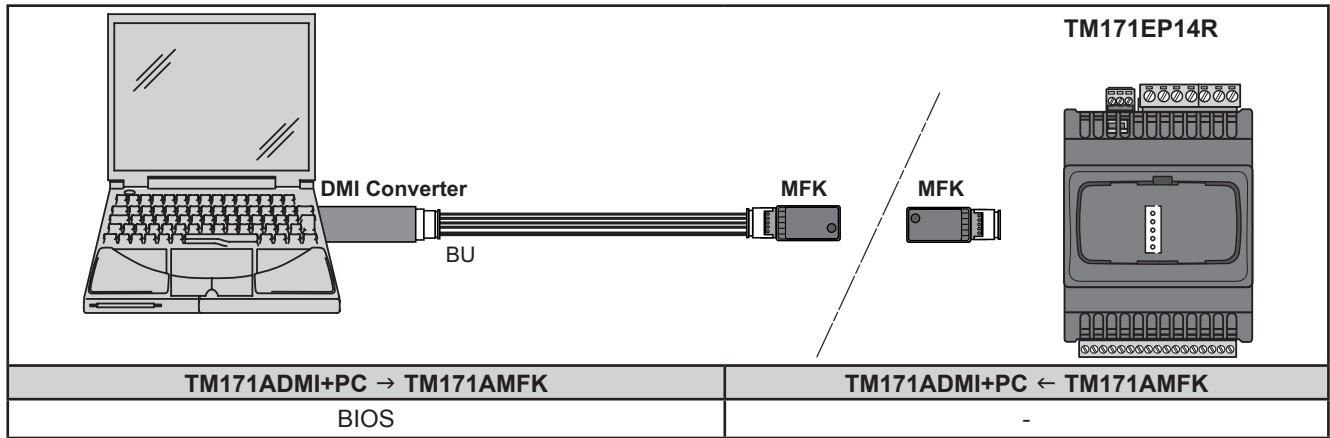

**Fig. 65.** Connections between TM171AMFK and TM171ADMI Converter + PC

### ⚠ WARNING

#### UNINTENDED EQUIPMENT OPERATION

- Connect the programming cable to the PC first, then to the programming port of the controller.
- Disconnect the programming cable from the controller before disconnecting it from the PC.

**Failure to follow these instructions can result in death, serious injury, or equipment damage**

