

Product data sheet

Specifications

SQUARE D



Circuit breaker, PowerPacT M,
800A, 3 pole, 600VAC, 18kA, lugs,
ET 1.0, 80%

MGP36800

Product availability: Stock - Normally stocked in distribution facility

Main

Range	PowerPact
Product name	PowerPact M
Product or Component Type	Circuit breaker
Device Application	Distribution

Complementary

Line Rated Current	800 A
Number of Poles	3P
Control Type	Operating handle
Breaking capacity code	G
Breaking capacity	AIR 65 kA 240 V AC 50/60 Hz UL 489 AIR 35 kA 480 V AC 50/60 Hz UL 489 AIR 18 kA 600 V AC 50/60 Hz UL 489 Icu 50 kA 240 V AC 50/60 Hz IEC 60947-2 Icu 35 kA 380/415 V AC 50/60 Hz IEC 60947-2
[Ue] rated operational voltage	600 V AC 50/60 Hz UL 489
Network Frequency	50/60 Hz
[Ics] rated service breaking capacity	25 kA 240 V AC 50/60 Hz IEC 60947-2 20 kA 380/415 V AC 50/60 Hz IEC 60947-2
[Uimp] rated impulse withstand voltage	8 kV IEC 60947-2
Trip unit technology	Electronic, basic, ET 1.0,
Magnetic tripping current	1600...8000 A
Continuous current rating	80 %
[Ui] rated insulation voltage	750 V IEC 60947-2
Trip unit name	ET 1.0
Suitability for isolation	Yes IEC 60947-2
Utilisation category	Category A
AWG gauge	3 x AWG 3/0...3 x 500 kcmil aluminium/copper
Local signalling	1 trip indicator (green)
Mounting mode	Unit mount lug)
Mounting Support	Lug
Electrical connection	Terminal nut, line Lugs, load
Terminal identifier	AL800M23K

Price is "List Price" and may be subject to a trade discount – check with your local distributor or retailer for actual price.

Long time pick-up adjustment range	300...800 A
Tightening torque	442.5 lbf.in (50 N.m) 0.1...0.4 in ² (95...240 mm ²) (3 x AWG 3/0...3 x 500 kcmil)
Number of slots	2 auxiliary switch OF plug-in) 1 alarm switch SD plug-in) 1 voltage release MN or MX plug-in)
Power wire stripping length	1.0 in (25 mm)
Color	Black
Height	12.86 in (326.64 mm)
Width	8.27 in (210.06 mm)
Depth	8.05 in (204.47 mm)
Net Weight	29 lb(US) (13.2 kg)
Quantity per Set	1
Circuit breaker application	HACR rated

Environment

Quality labels	CE
Standards	UL CSA NEMA NOM-003-SCFI-2000 IEC 60947-2
Product certifications	UL CSA NOM
IP degree of protection	IP40
Pollution degree	3 IEC 60947-1
Ambient Air Temperature for Operation	-13...158 °F (-25...70 °C)
Ambient Air Temperature for Storage	-58...185 °F (-50...85 °C)
Operating altitude	< 6561.68 ft (2000 m) without derating 13123.36 ft (4000 m) with derating

Ordering and shipping details

Category	US10DE201205
Discount Schedule	0DE2
GTIN	00785901502494
Returnability	Yes
Country of origin	MX

Packing Units

Unit Type of Package 1	PCE
Nbr. of units in pkg.	1
Package 1 Height	10.800 in (27.432 cm)
Package 1 Width	12.100 in (30.734 cm)
Package 1 Length	17.900 in (45.466 cm)
Package weight(Lbs)	28.0009 lb(US) (12.701 kg)

Unit Type of Package 2	PAL
Number of Units in Package 2	32
Package 2 Height	44.000 in (111.760 cm)
Package 2 Width	40.000 in (101.600 cm)
Package 2 Length	48.000 in (121.920 cm)
Package 2 Weight	920.999 lb(US) (417.758 kg)

Contractual warranty

Warranty	18 months
-----------------	-----------



Environmental Data

Schneider Electric aims to achieve Net Zero status by 2050 through supply chain partnerships, lower impact materials, and circularity via our ongoing “Use Better, Use Longer, Use Again” campaign to extend product lifetimes and recyclability.

[Environmental Data explained >](#)

[How we assess product sustainability >](#)

Environmental footprint	
Carbon footprint (kg CO2 eq, Total Life cycle)	1449
Environmental Disclosure	Product Environmental Profile

Use Better

Materials and Substances	
Packaging made with recycled cardboard	Yes
Packaging without single use plastic	Yes
EU RoHS Directive	Compliant with Exemptions
SCIP Number	21500b23-9fd3-49c7-8372-6c1a79b6c751
REACH Regulation	REACH Declaration
California proposition 65	WARNING: This product can expose you to chemicals including: DINP, which is known to the State of California to cause cancer, and DIDP, which is known to the State of California to cause birth defects or other reproductive harm. For more information go to www.P65Warnings.ca.gov
PVC free	Yes

Use Again

Repack and remanufacture	
Circularity Profile	End of Life Information
Take-back	No

Technical Illustration

Dimensions

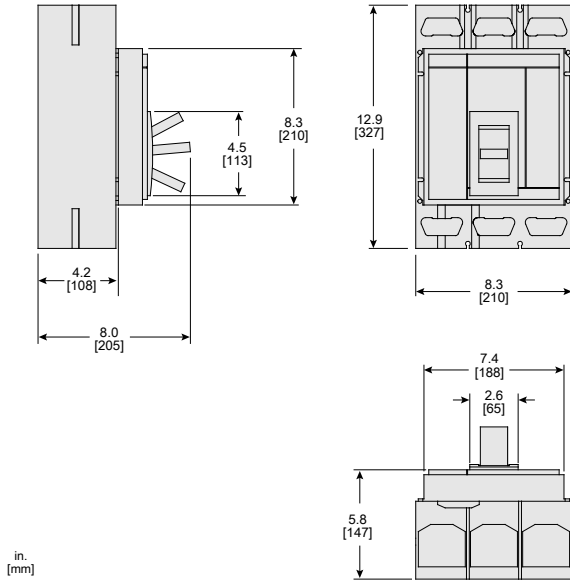

ALL DIMENSIONS ARE APPROXIMATE.
REFER TO CAD, TECHNICAL DRAWINGS, AND DOCUMENTATION FOR COMPLETE INFORMATION.